

a) $1 \text{ second} < 1 \text{ minute} \times 60$ $\square \times 60$ 1 hour $\square \times \square$ 1 day $\square \times \square$ 1 week

b) $1 \text{ hour} = \square \text{ seconds}$, $1 \text{ month} \approx \square \text{ days}$, $1 \text{ year} \approx \square \text{ weeks}$
 $1 \text{ year} = \square \text{ days}$, $1 \text{ year} = \square \text{ months}$, $1 \text{ day} = \square \text{ hours}$

c) $85 \text{ minutes} \square 1 \text{ hour } 25 \text{ minutes}$, $1 \text{ week} = \square \text{ hours}$

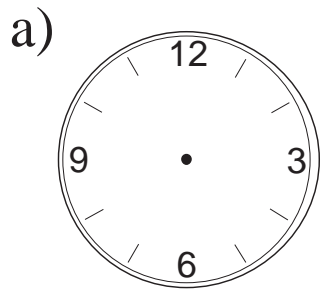

7 hrs 25 min

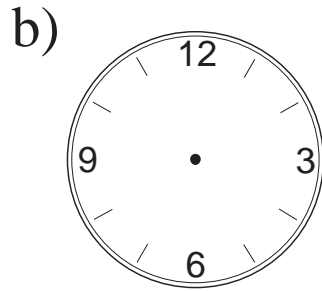

05:55

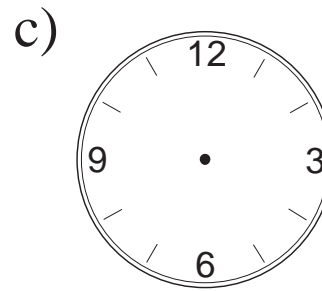

20 min to 8

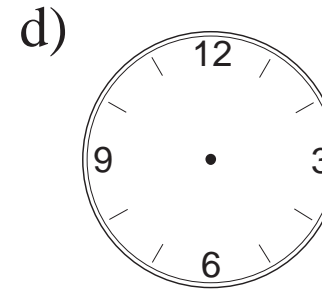

0 hrs 5 min

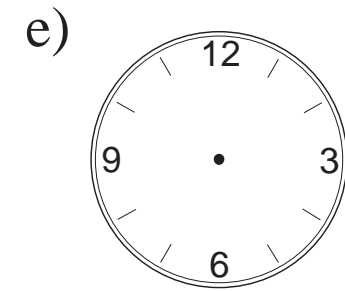

15 h 20 min 45 sec

LP 31/5

a) morning

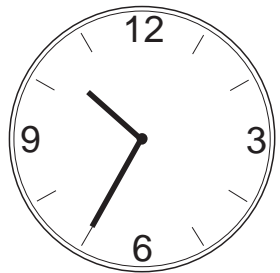

b) evening



c) afternoon

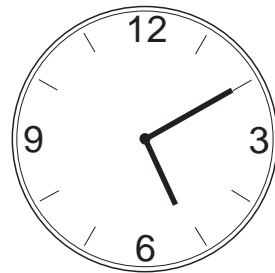

d) night

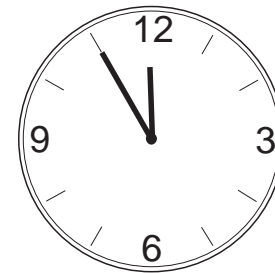

e) night

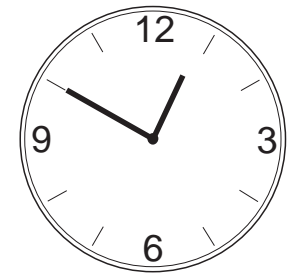

LP 31/6

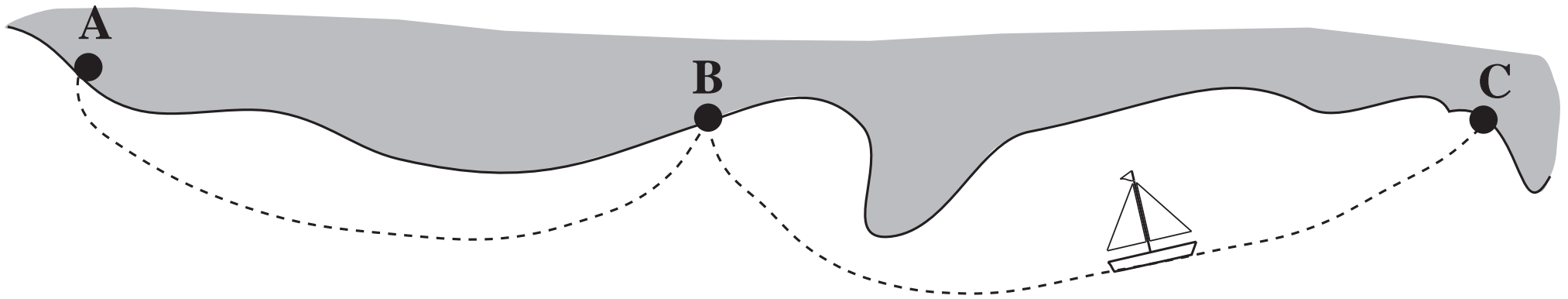

LP 32/7

Quantity	15 kg	1 kg	2 kg	5 kg	11 kg	20 kg	27 kg	30 kg	150 kg
Price	£9.45	p							

LP 33/8

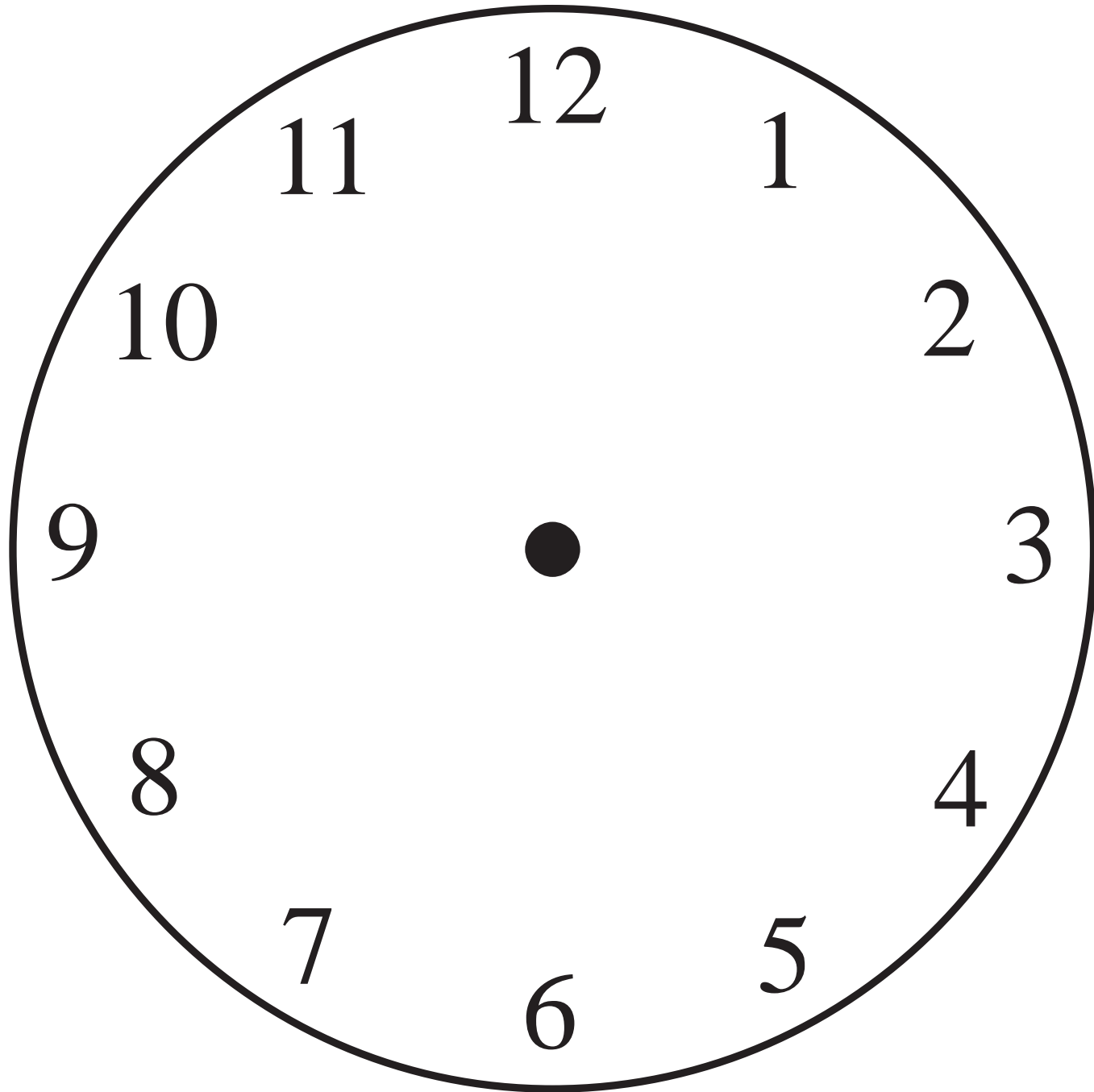

a) $\frac{1}{4}$ hour = min. = sec.

b) $\frac{3}{4}$ hour = min. = sec.

c) $\frac{1}{2}$ hour = min. = sec.

d) $\frac{3}{2}$ hour = min. = sec.

e) $\frac{1}{3}$ hour = min. = sec.

f) $\frac{2}{3}$ hour = min. = sec.

g) $\frac{1}{5}$ hour = min. = sec.

h) $\frac{3}{5}$ hour = min. = sec.

i) $\frac{1}{6}$ hour = min. = sec.

j) $\frac{5}{6}$ hour = min. = sec.

k) $\frac{1}{8}$ hour = min. = sec.

l) $\frac{7}{8}$ hour = min. = sec.

m) $\frac{1}{10}$ hour = min. = sec.

n) $\frac{3}{10}$ hour = min. = sec.

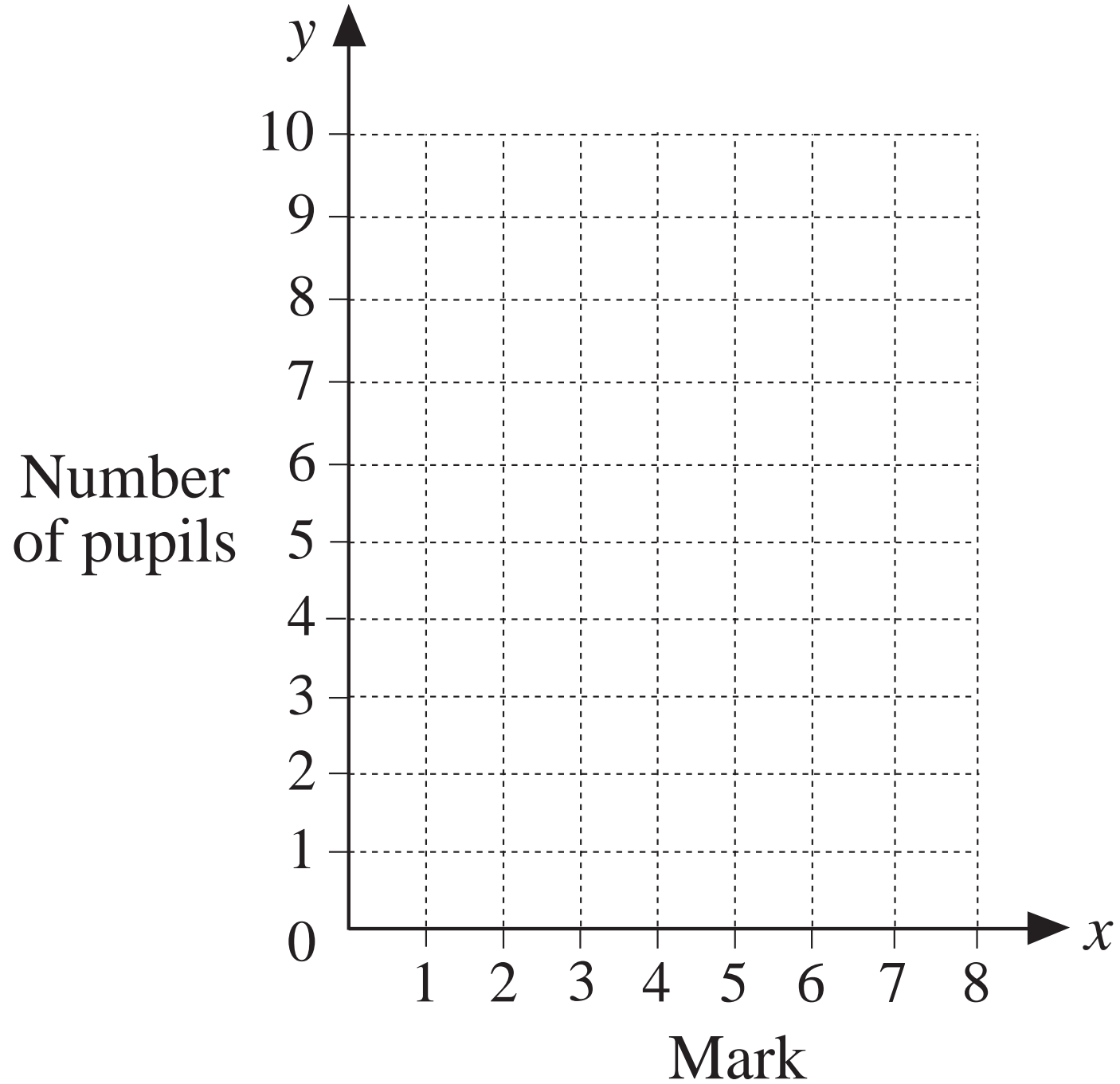

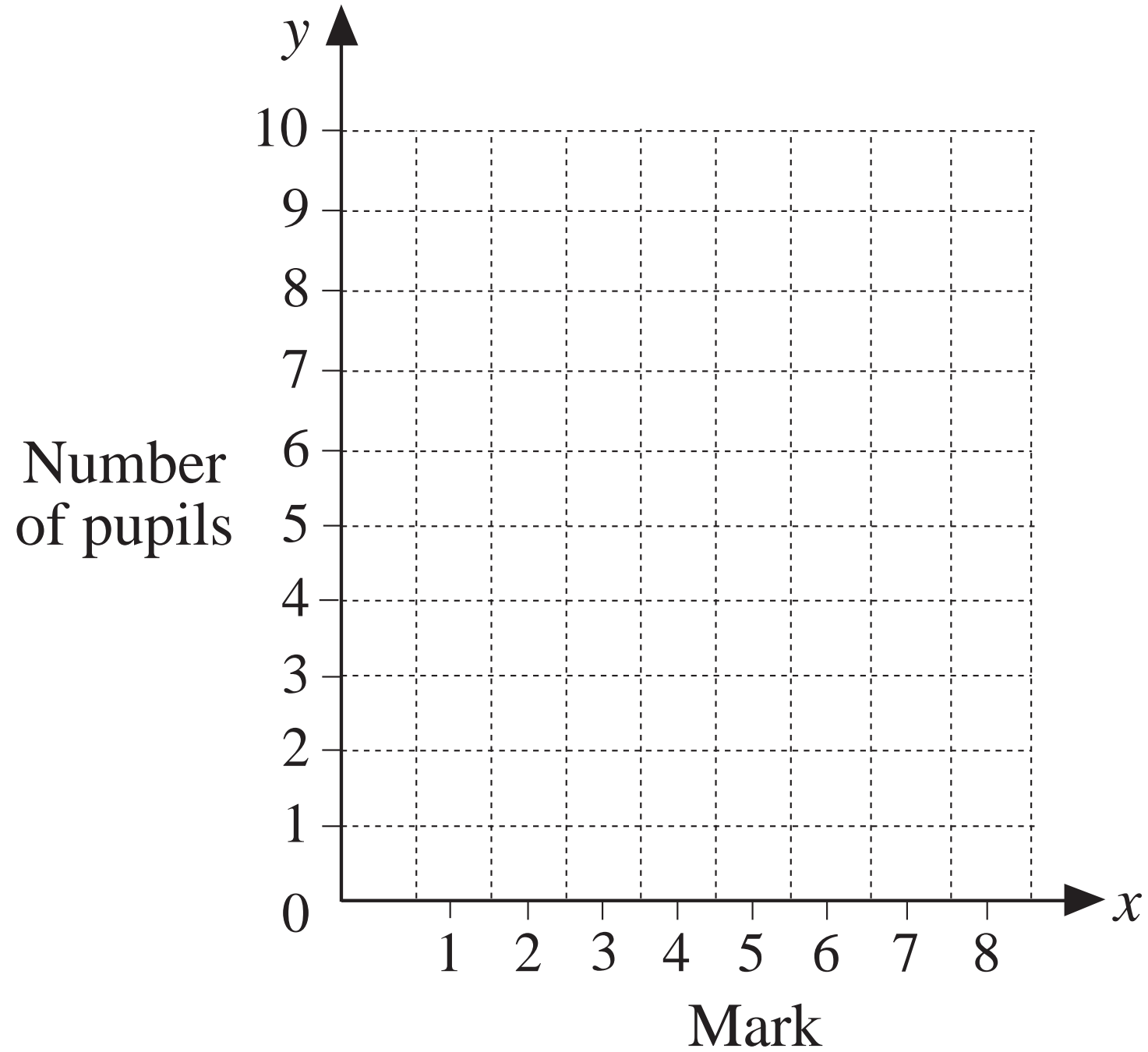

Water level (cm)

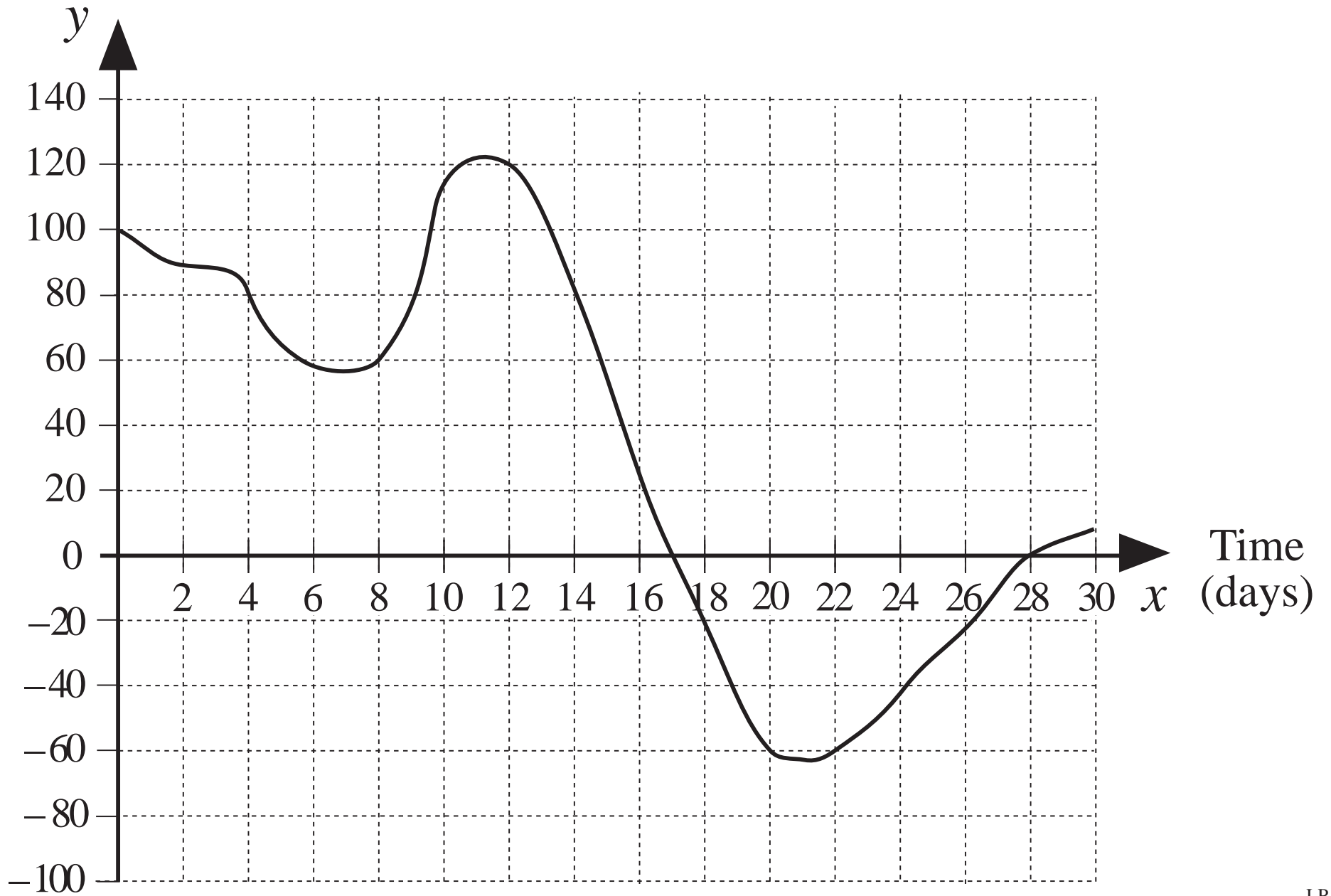

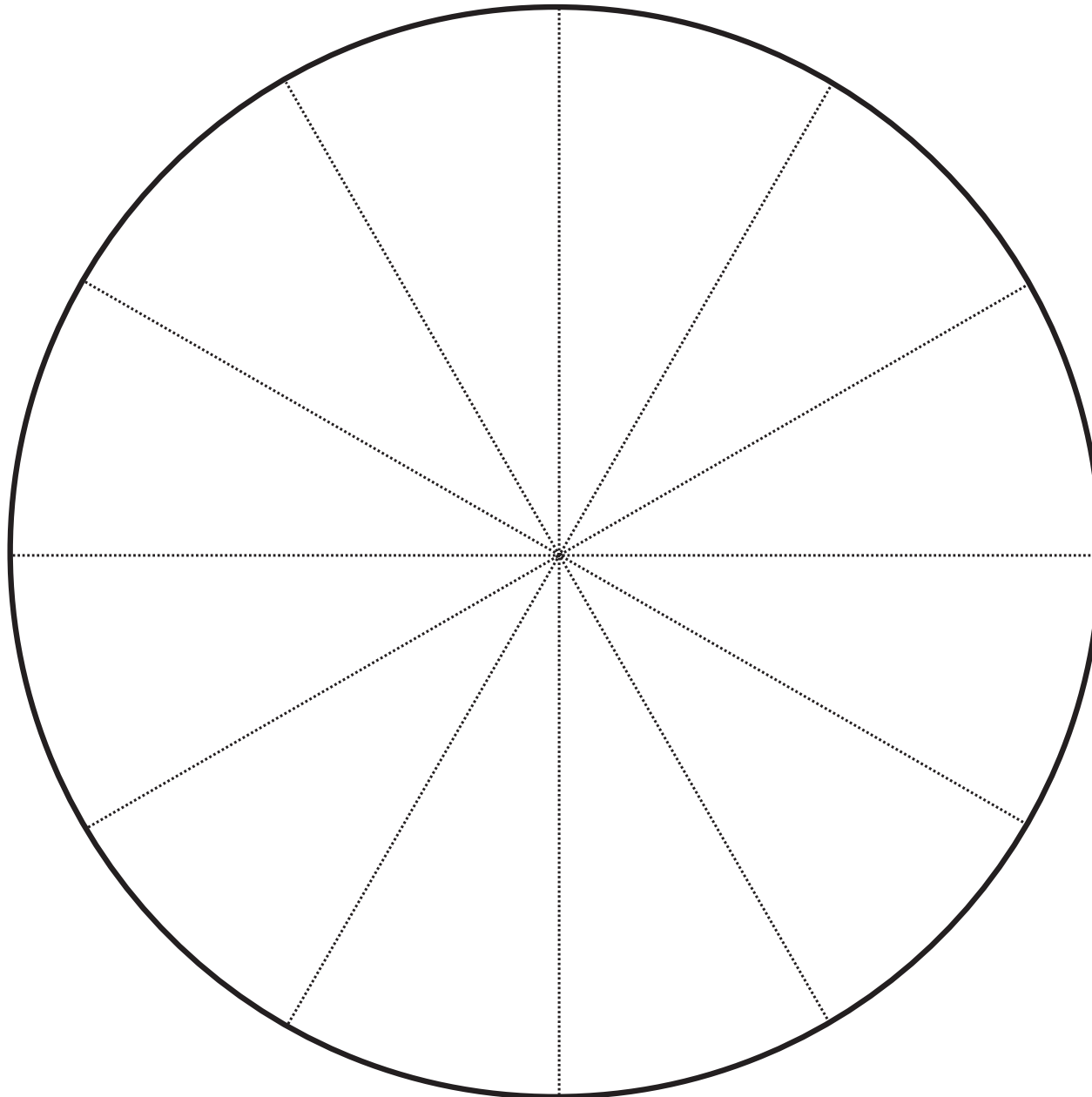

- French
- English
- Music
- Maths
- Science
- P.E

Colour circle and key appropriately

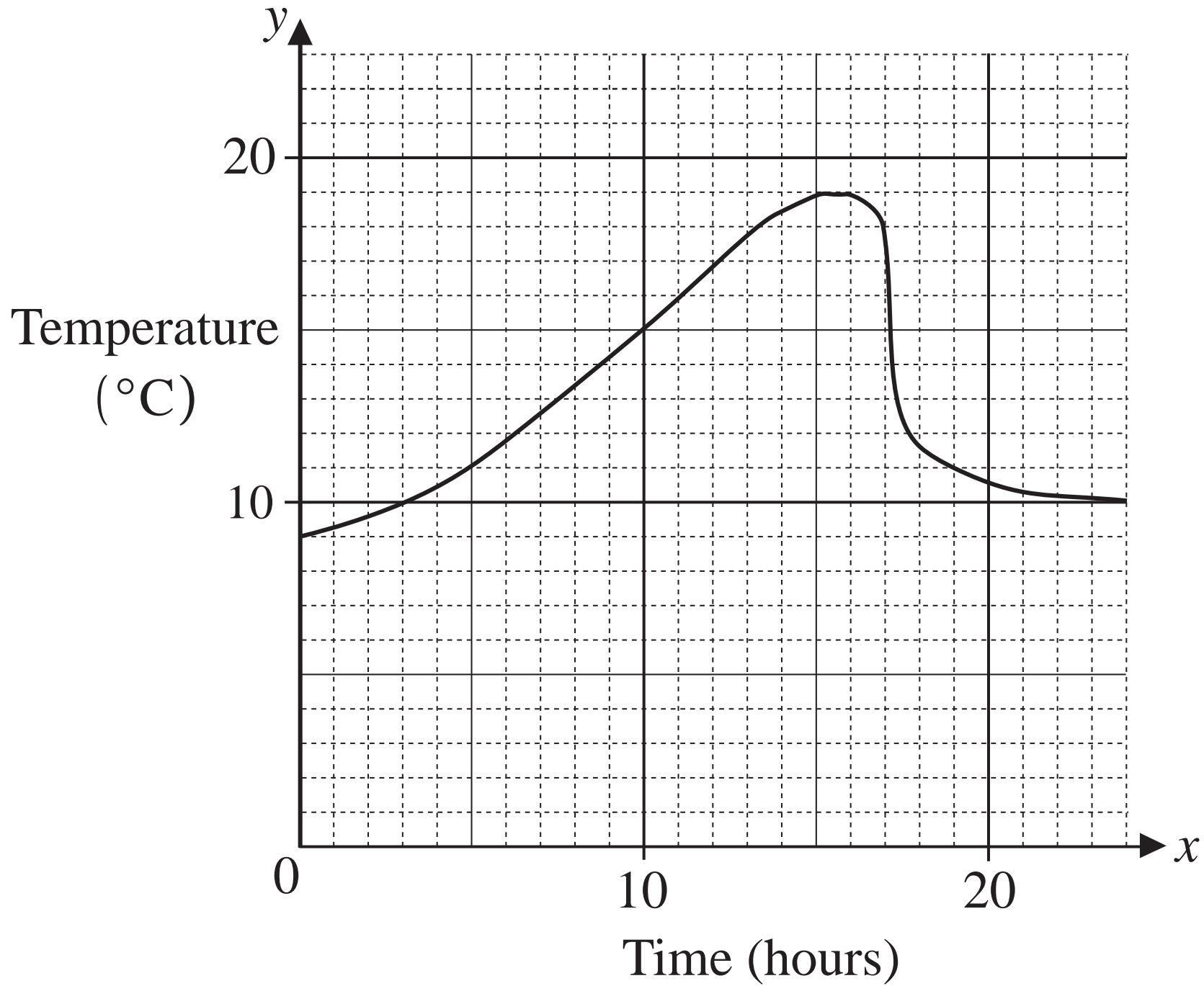

Temperature ($^{\circ}\text{C}$)

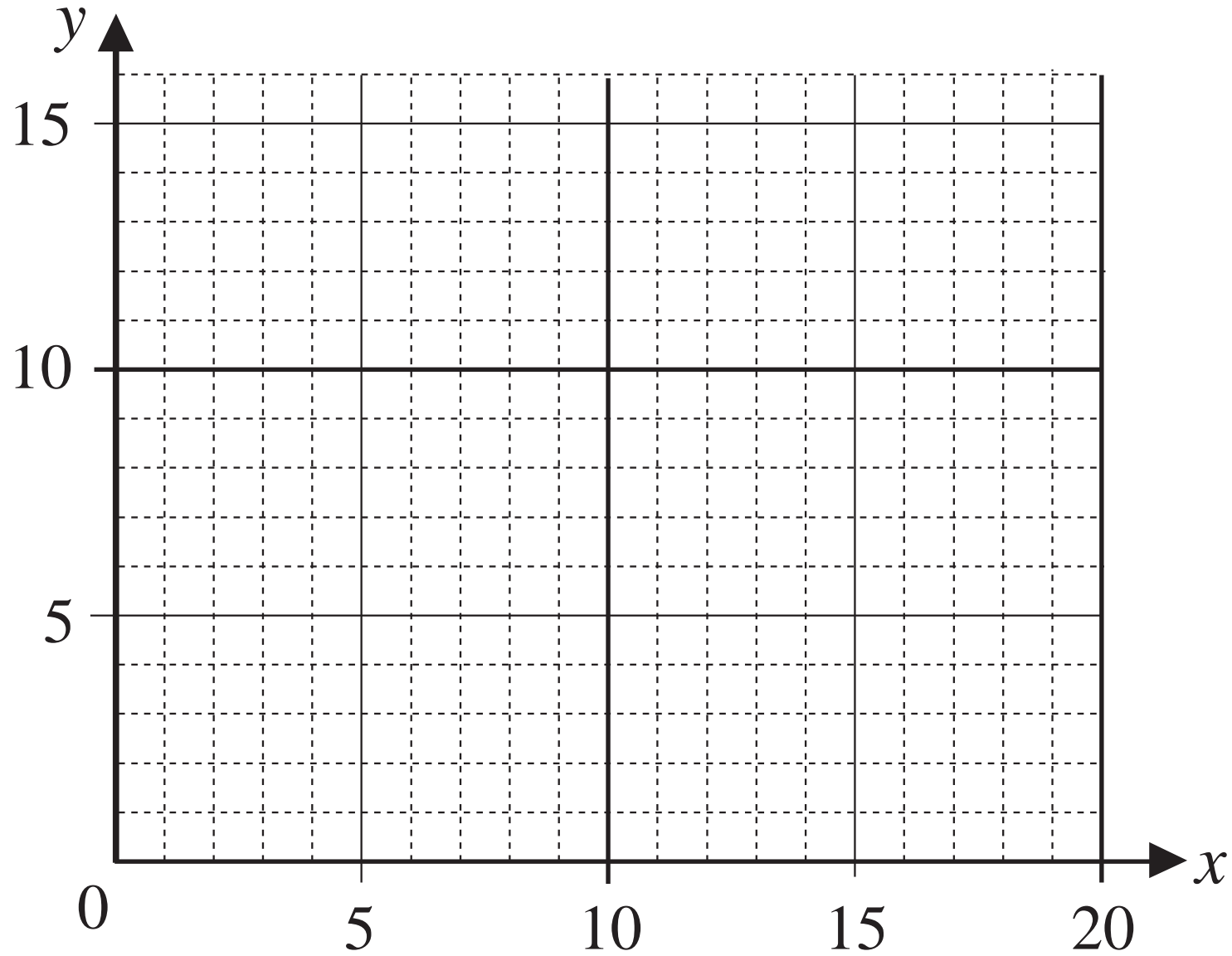

Time (hours)

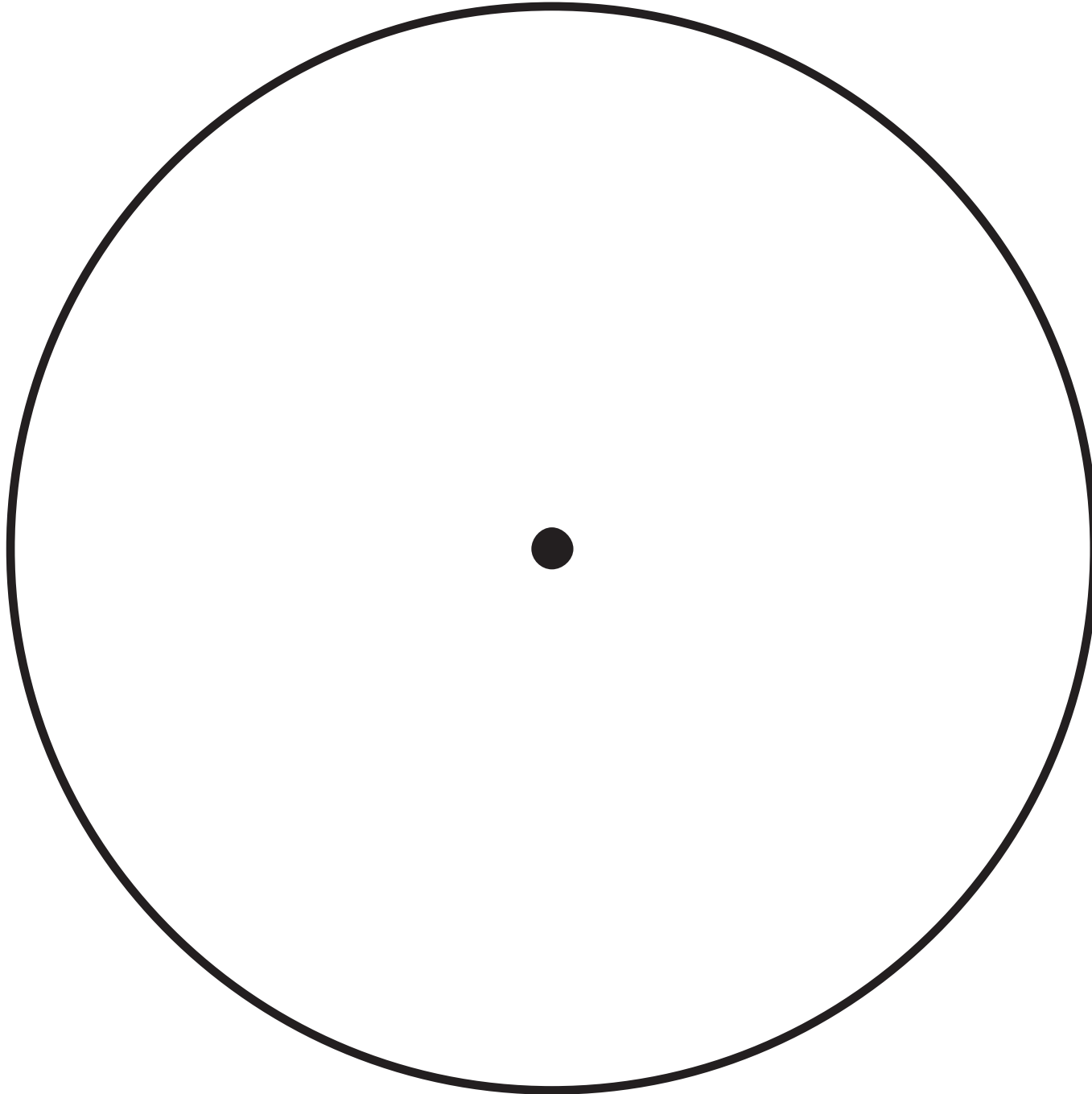

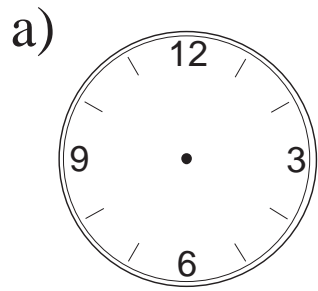

13:25

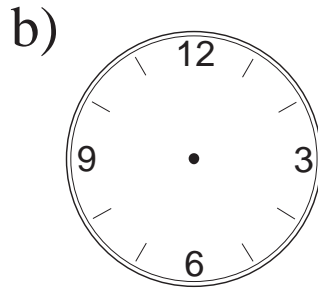

ten to seven

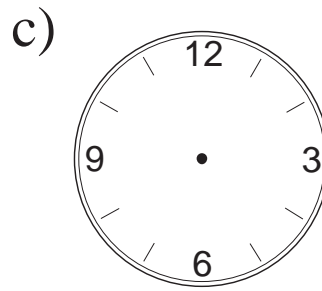

9.12 am

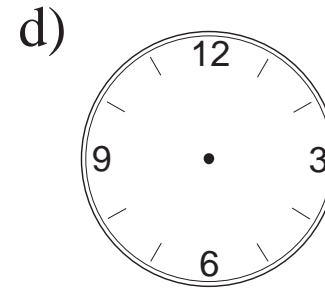

5 h 40 min

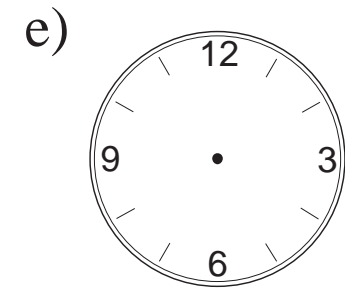

twenty-five to three

LP 35/1

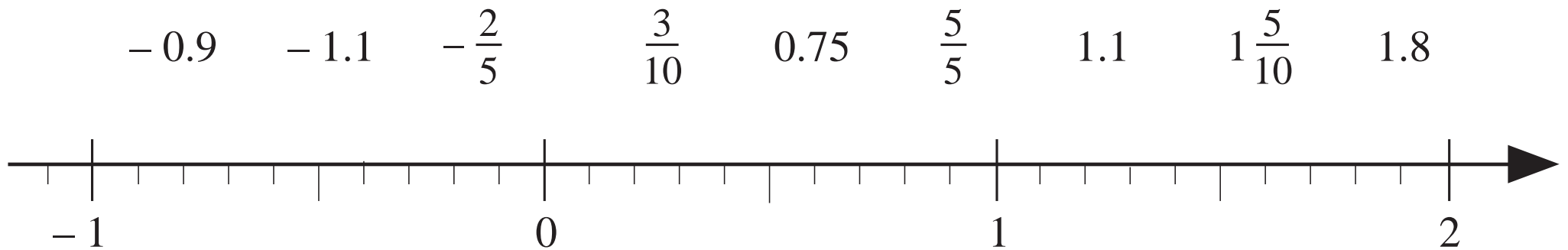

LP 35/4

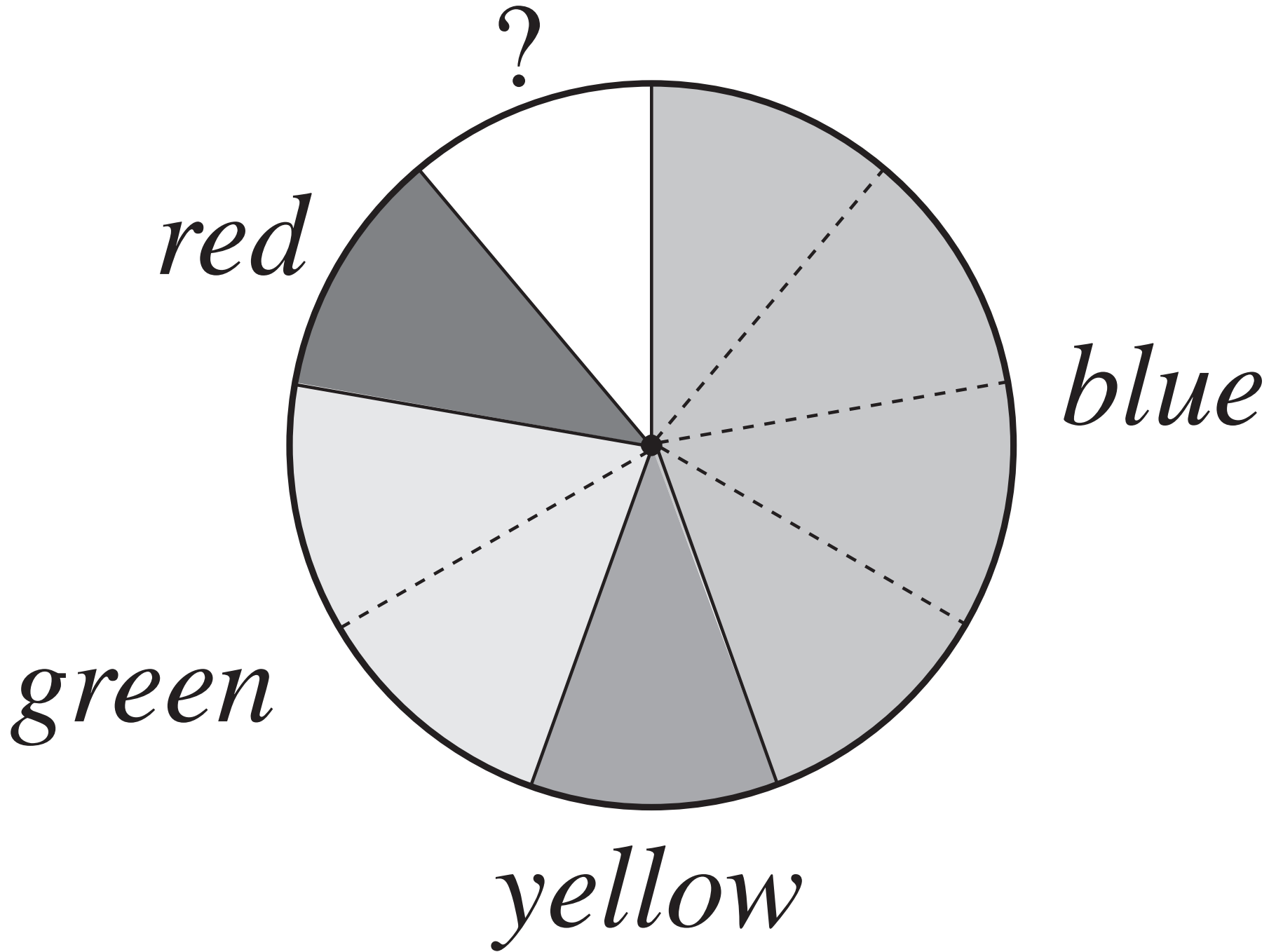

a)

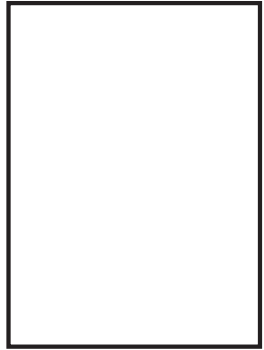

$$b = 4 \frac{1}{4} \text{ m}$$

$$a = 2 \text{ m } 10 \text{ cm}$$

$$a = 210 \text{ cm}$$

$$b = 440 \text{ cm}$$

$$A = 2 \times (210 + 440) \text{ cm} = \underline{1300 \text{ cm}}$$

$$P = 440 \text{ cm} \times 210 \text{ cm} = \underline{92\,400 \text{ cm}^2}$$

b)

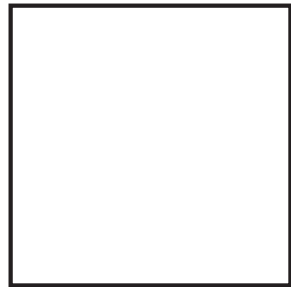

$$a = 3 \frac{1}{2} \text{ m}$$

$$P = 2 \times (3 \frac{1}{2} + 3 \frac{1}{2}) \text{ m} = 2 \times 7 \text{ m} = \underline{14 \text{ m}}$$

$$A = 3 \frac{1}{2} \text{ m} \times 3 \frac{1}{2} \text{ m} = \underline{9 \frac{1}{2} \text{ m}^2}$$

a)

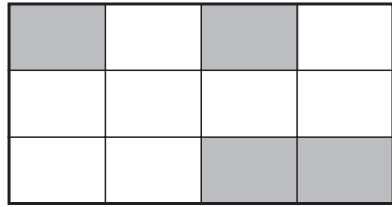
 $\frac{1}{3}$

b)

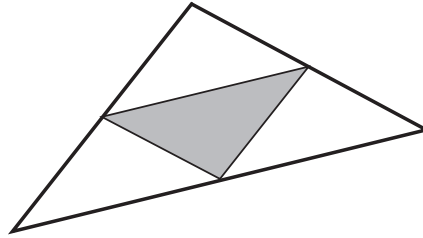
 $\frac{3}{4}$

c)

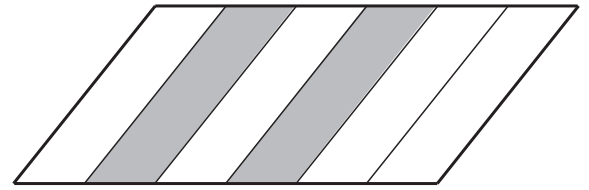
 $\frac{5}{6}$

LP 36/6

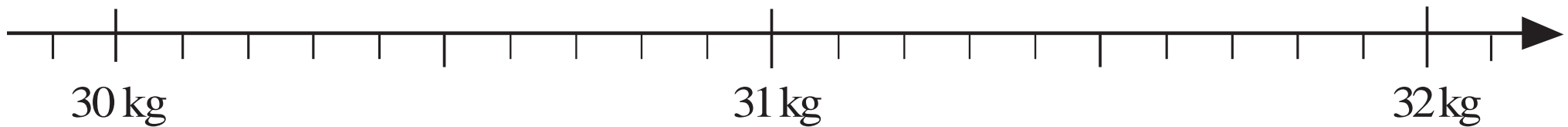

LP 36/7

a) $(32 + 18) - 16$ $32 + (18 - 16)$

b) $518 - (281 - 81)$ $(518 - 281) - 81$

c) $480 + 237$ $482 + 235$

d) $6512 - 6227$ $6510 - 6329$

e) $(17 + 5) \times 7$ $17 + 5 \times 7$

f) $(6 \times 8) \times 2$ $(6 \times 2) \times (8 \times 2)$

g) 480×60 $400 \times 60 + 80 \times 60$

h) 480×60 $500 \times 60 - 20 \times 60$

a)

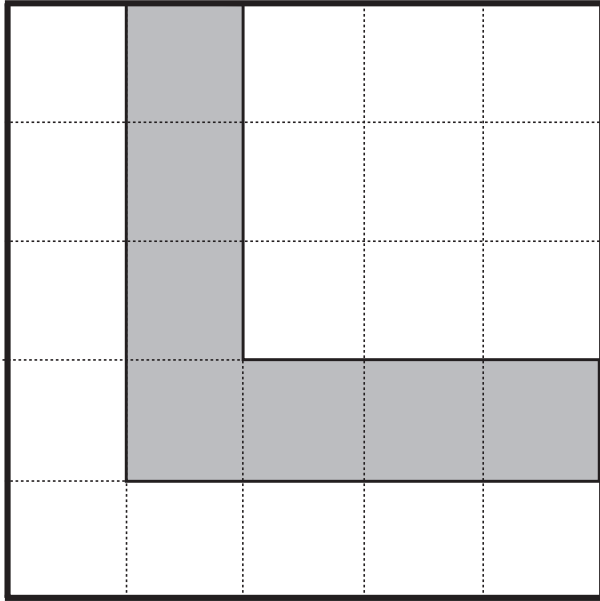

b)

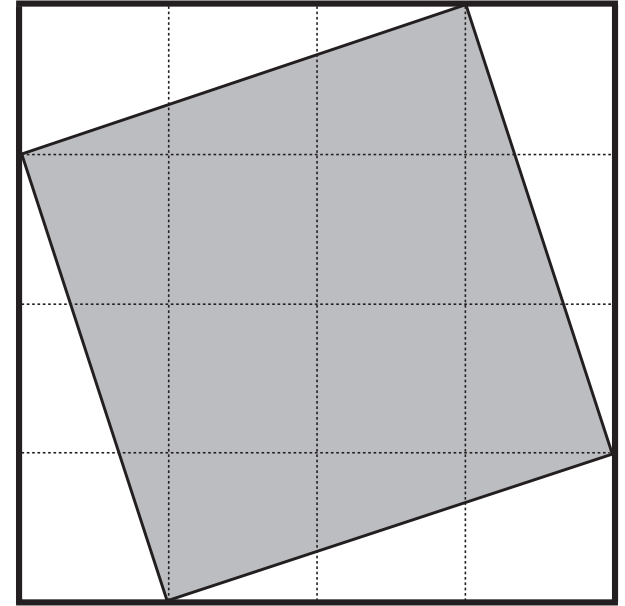

c)

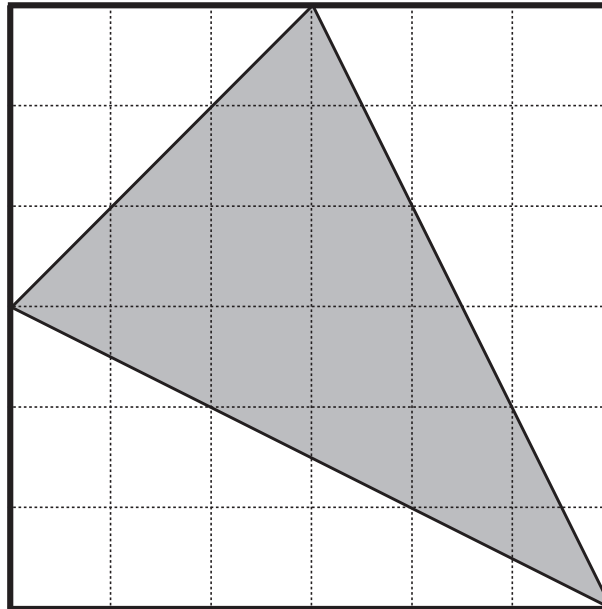

Chairman	A	A																
Secretary	B	C																

LP 37/7

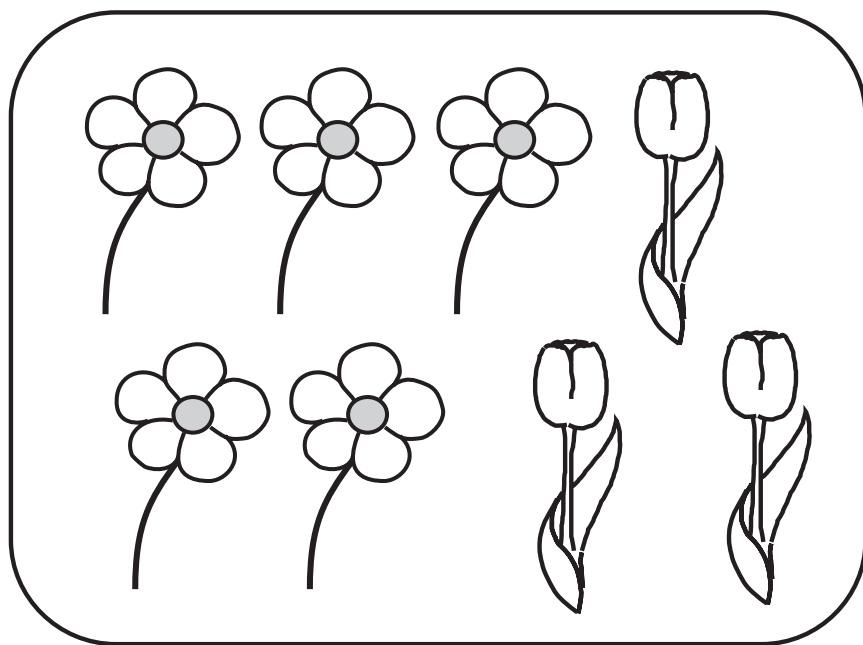

=

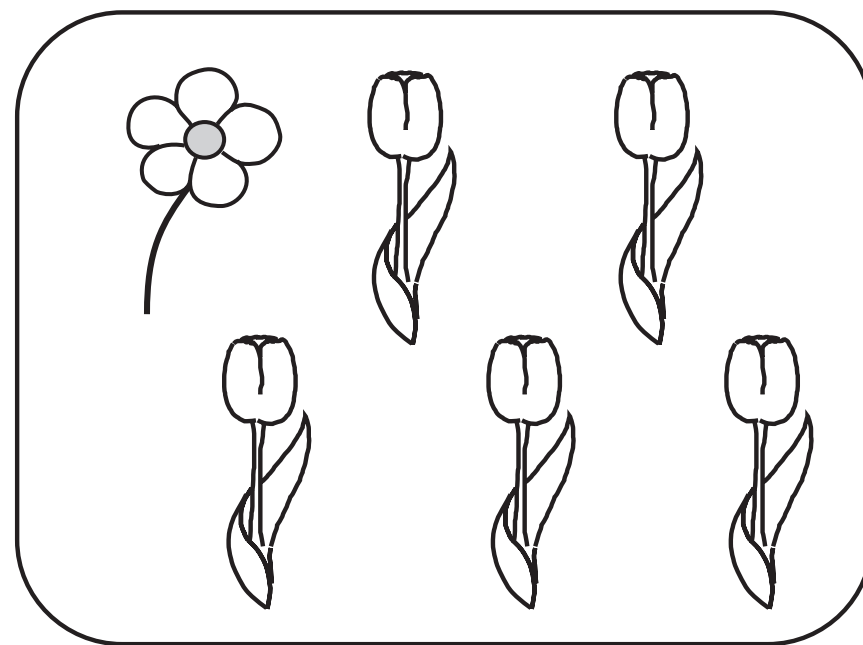

LP 37/9c

O	R	A	N
R	A	N	G
A	N	G	E

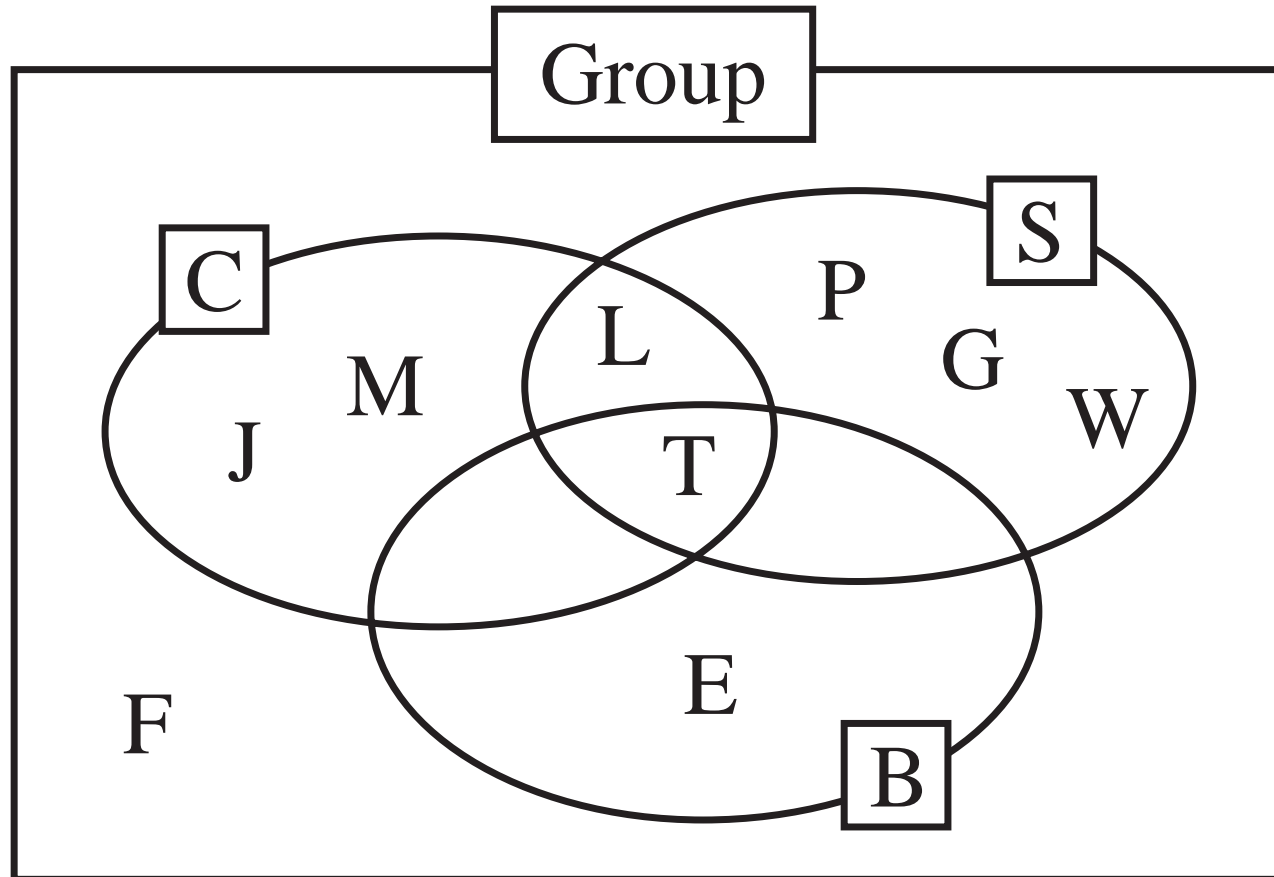

$B = \{\text{children who ate biscuits}\}$

$C = \{\text{children who ate chocolate}\}$

$S = \{\text{children who ate sweets}\}$

a)

	A	B	C	D	E
A					
B					
C					
D					
E					

Goodbyes

b)



E •

• D

Handshakes

a)

			1	9	8
		2	0	4	0
+	9	9	9	0	3
<hr/>					

b)

	4	4	8	9
-	1	2	9	4
<hr/>				

c)

		3	0	6
		×	3	5
<hr/>				
<hr/>				

d)

		7	9	6
		×	4	1
<hr/>				
<hr/>				

e)

7	4	5	0
<hr/>			

f)

1	0	5	3	7	7
<hr/>					

g)

1	1	1	1	1	1	1	1
<hr/>							

h)

1	0	0	4	6	5	3	0
<hr/>							

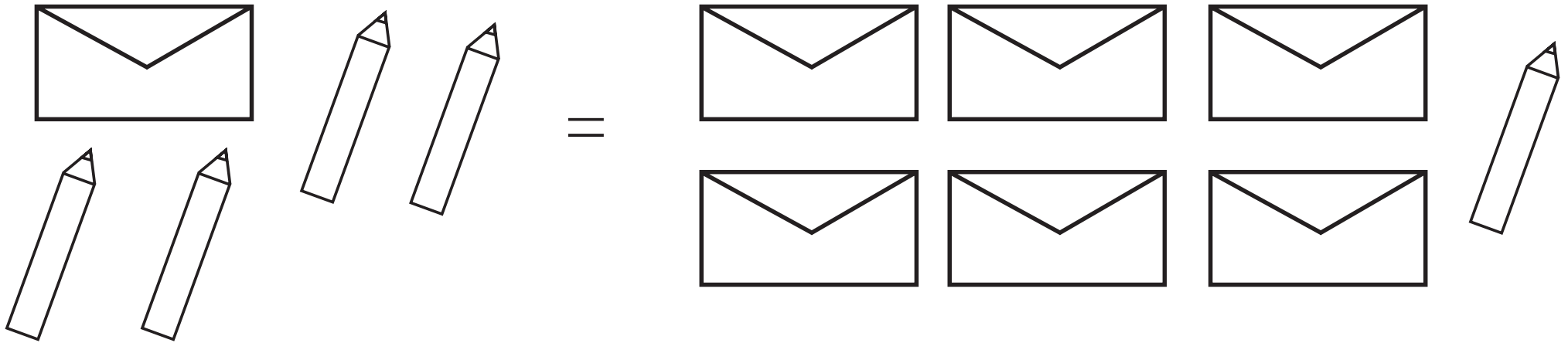

LP 39/5

a)

E
X
E
T
E
R



b)

E	X
X	E
E	T
T	E
E	R



c)

E	X	E
X	E	T
E	T	E
T	E	R



Route	Departs	Arrives	Journey time
London – Birmingham	09:15	<input type="text"/>	1 hour 20 minutes
London – Manchester	10:05	12:03	<input type="text"/>
Liverpool – London	<input type="text"/>	09:37	2 hours 11 minutes
Manchester – Glasgow	08:49	<input type="text"/>	2 hours 23 minutes
London – Carlisle	<input type="text"/>	15:12	3 hours 17 minutes
Glasgow – London	17:30	<input type="text"/>	4 hours 12 minutes

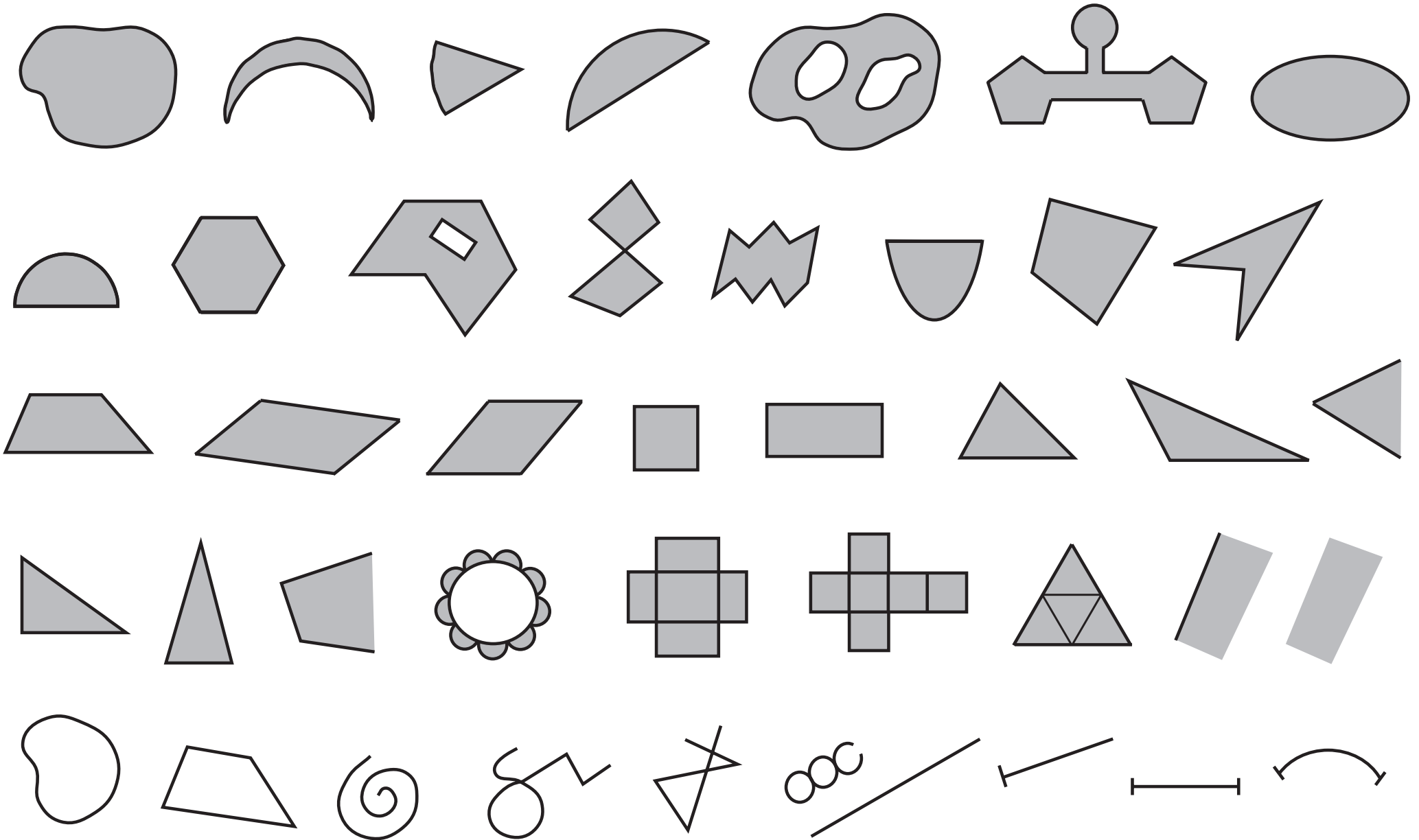

chair

grape

circle drawn on
a sheet of paper

piece of
tissue paper

solid

line

surface

thick cardboard

fine thread

grain of sand

skin of a grape

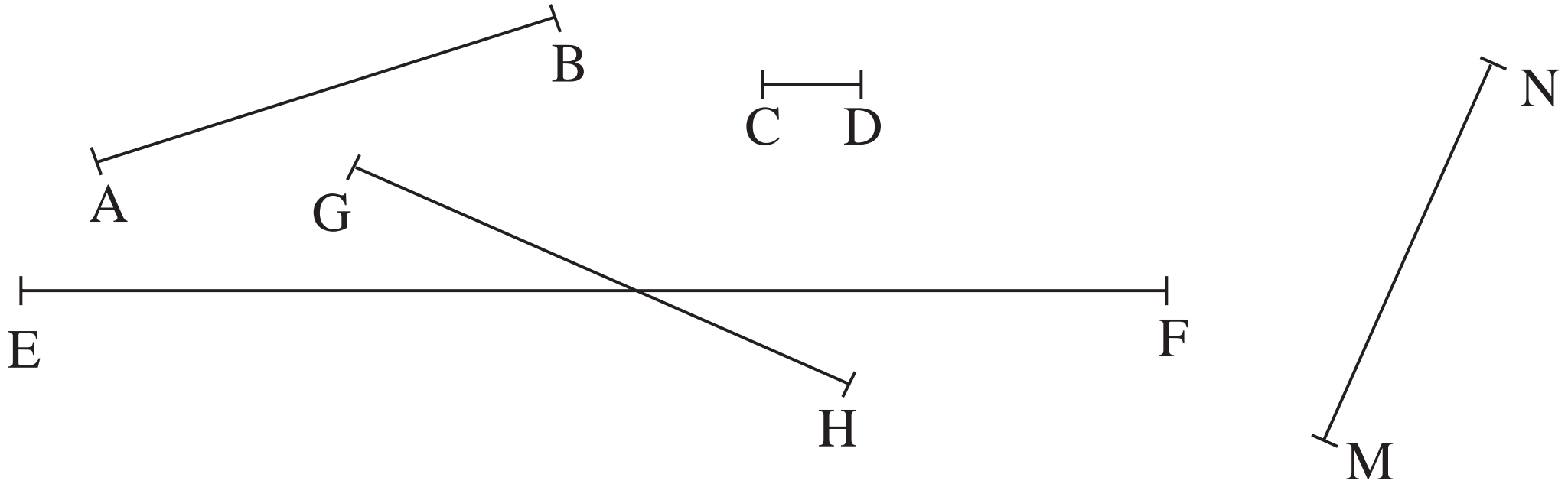

	AB	CD	EF	GH	MN
Estimated (cm)					
Measured (mm)					
Difference (mm)					

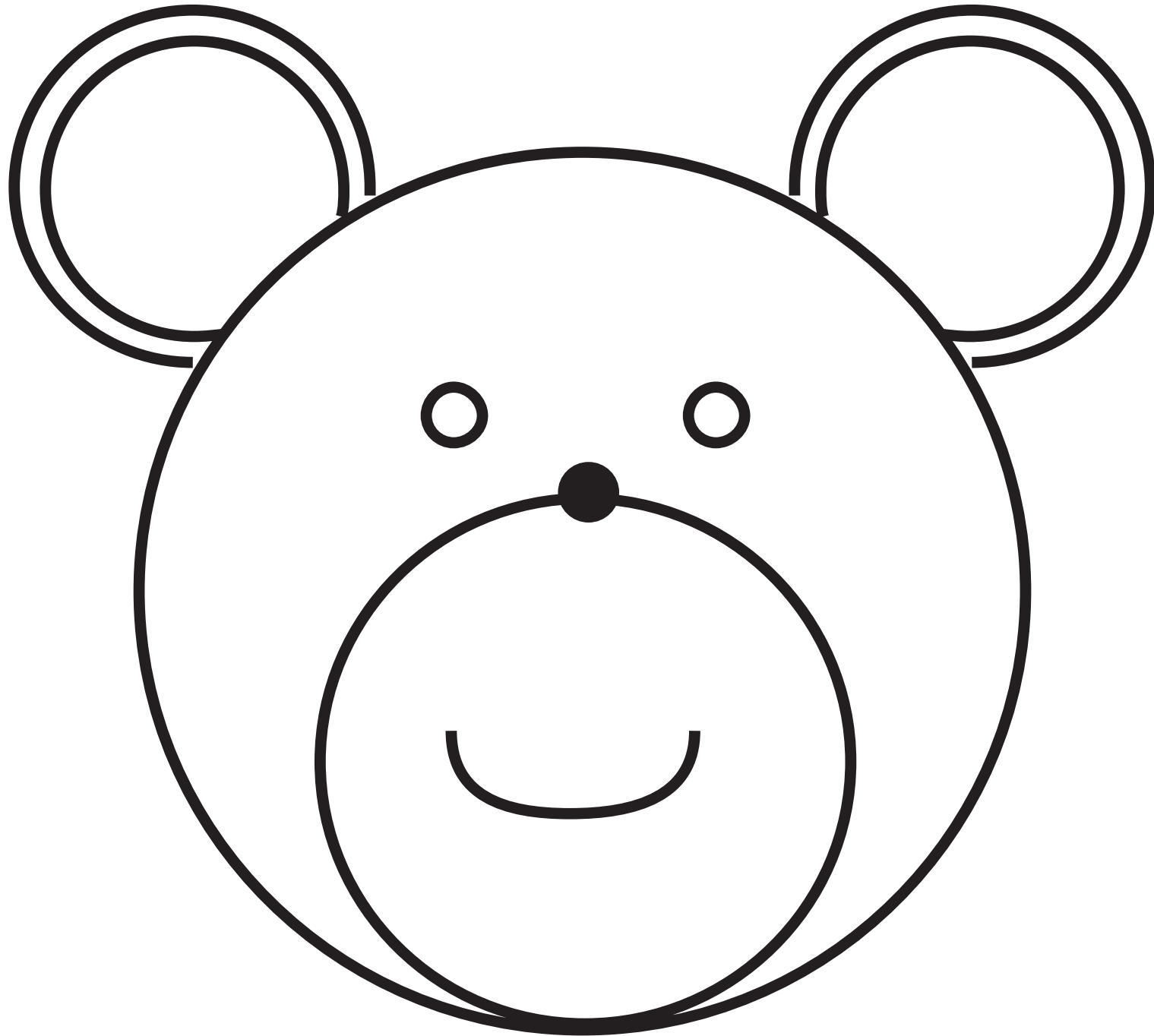

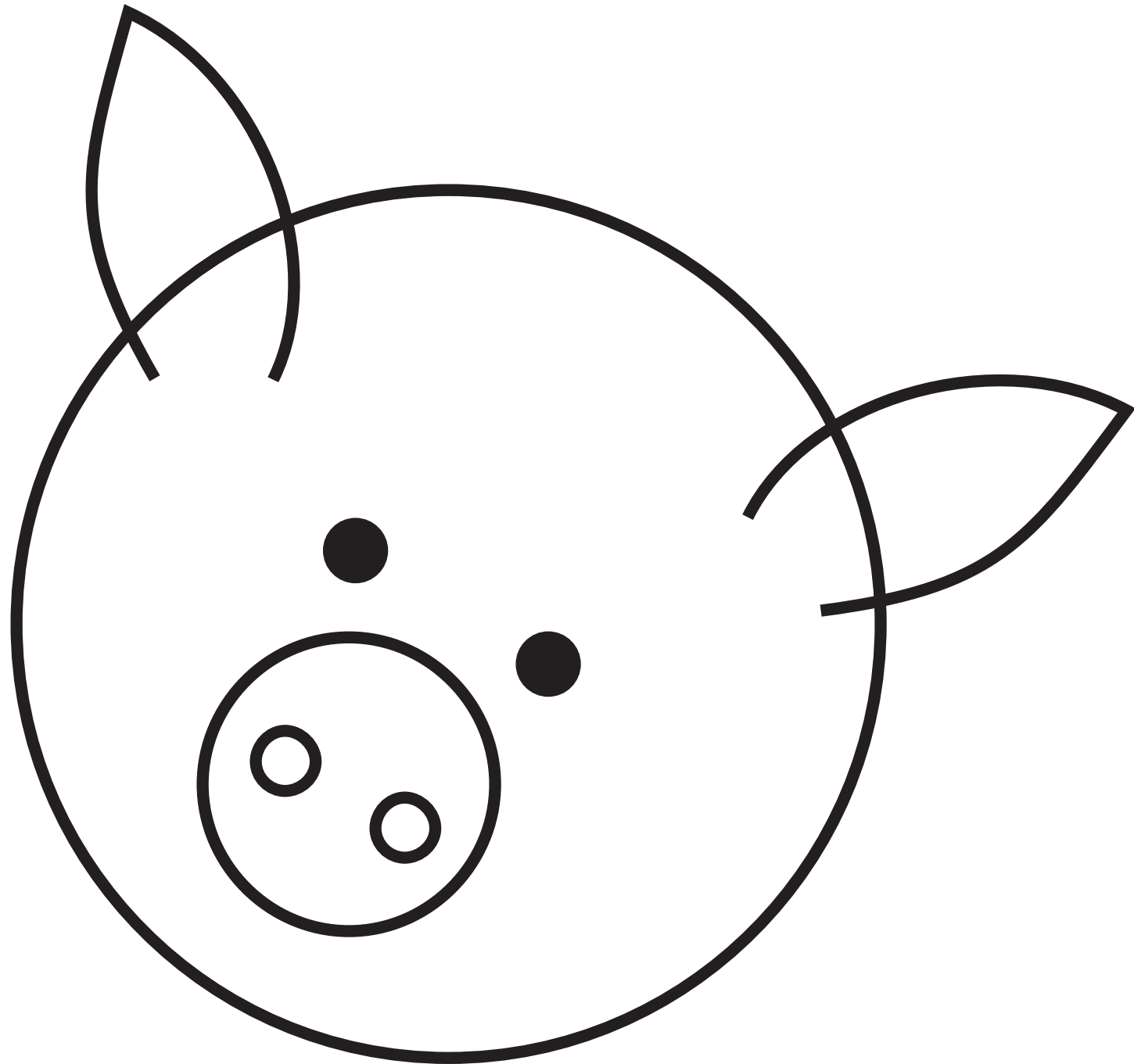

a

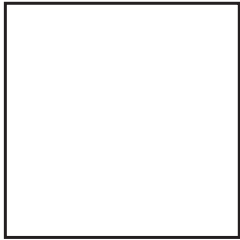

b

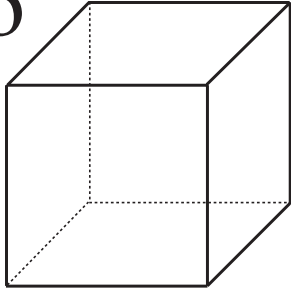

c



d

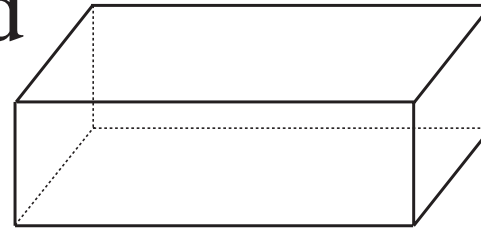

e

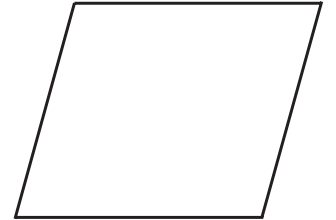

f

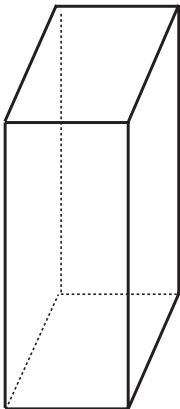

g

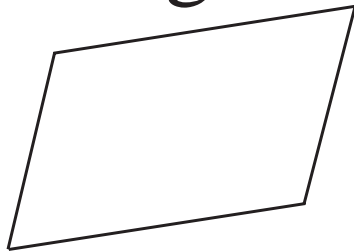

h

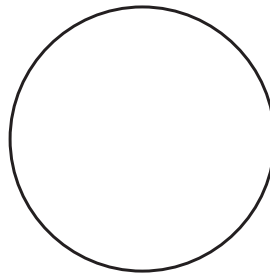

i

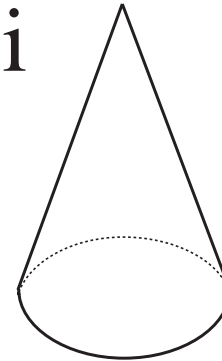

j

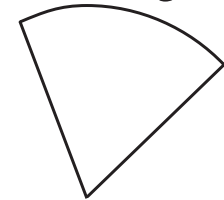

a)

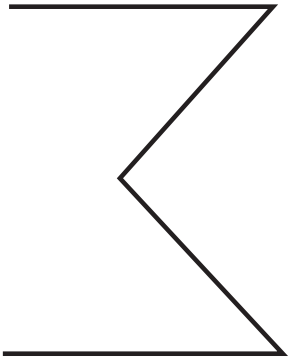

b)

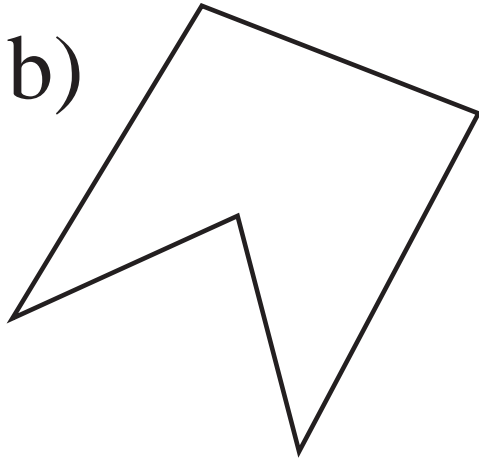

c)

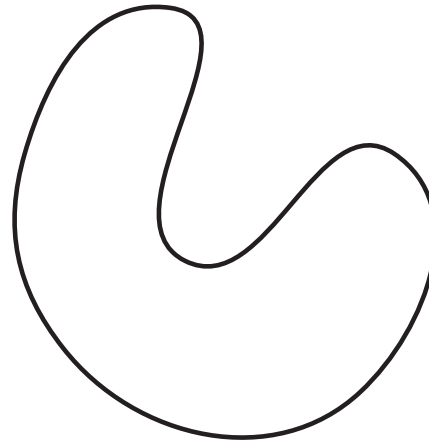

d)

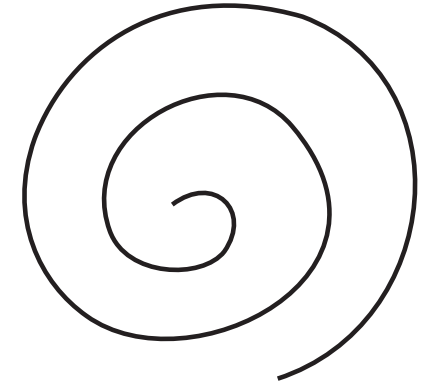

e)

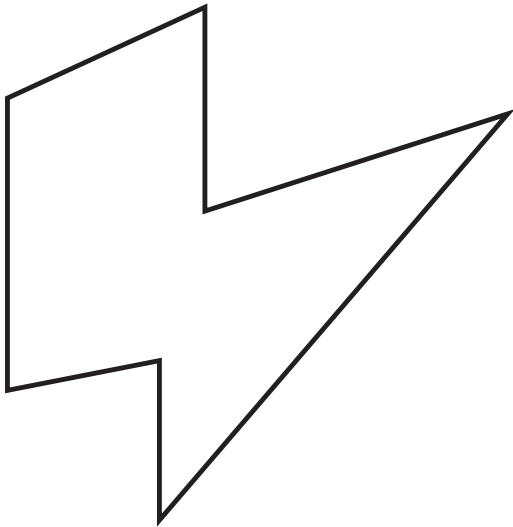

f)

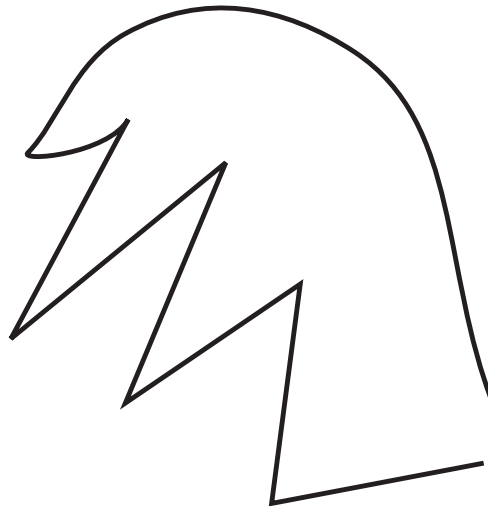

g)

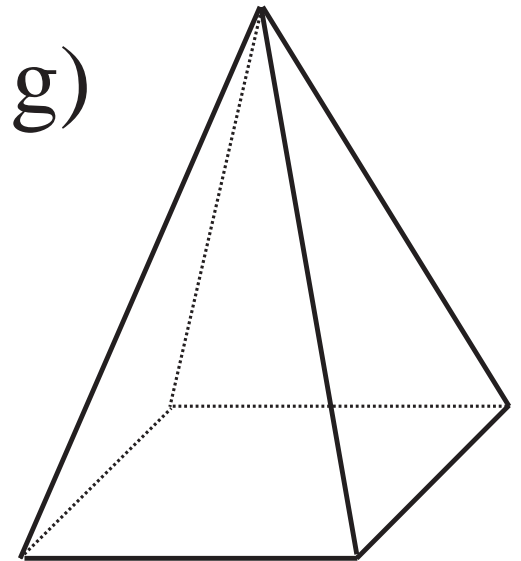

ray

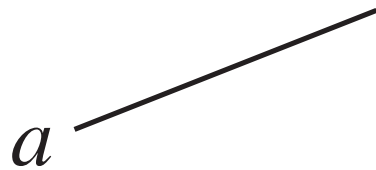

perpendicular lines

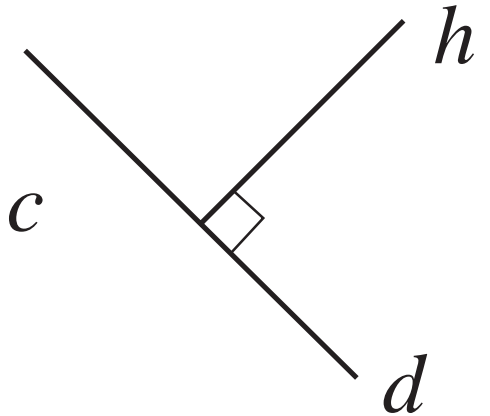
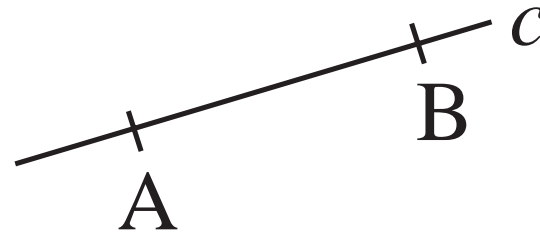
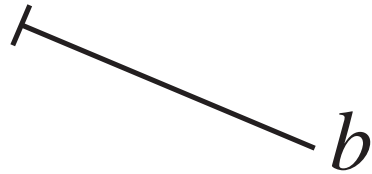

line segment

straight line

parallel lines

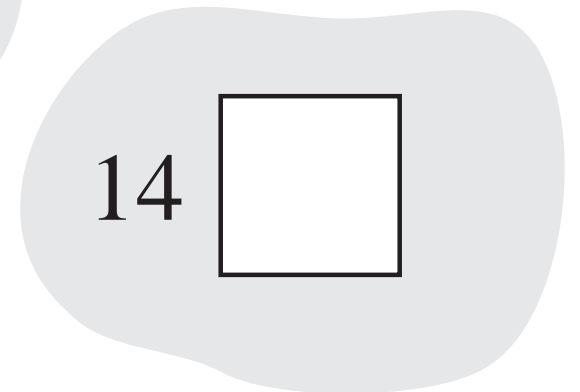
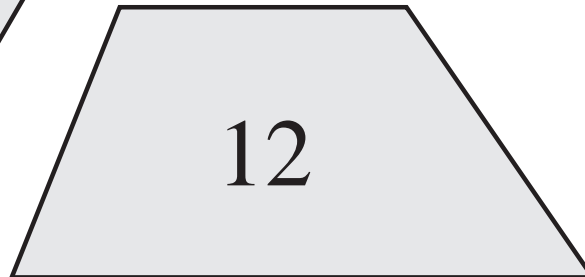
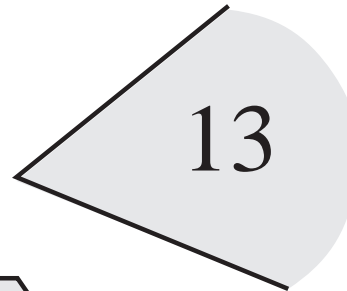
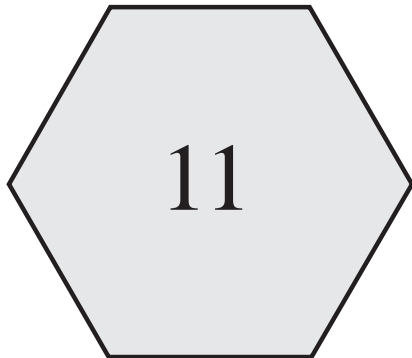
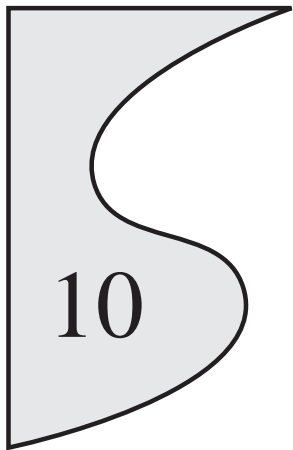
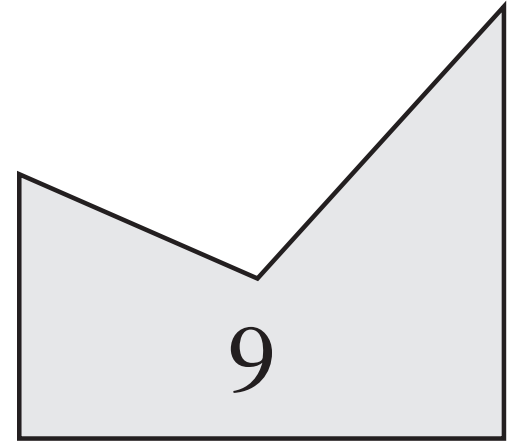
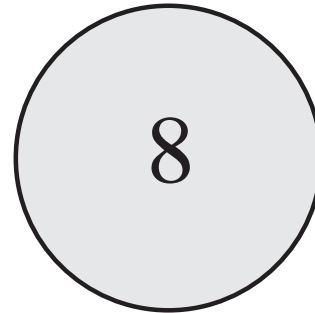
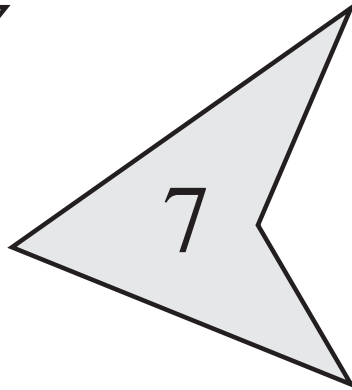
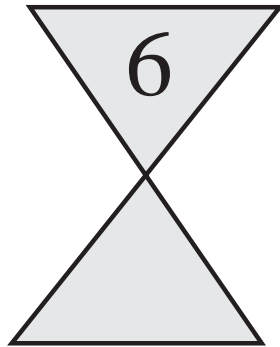
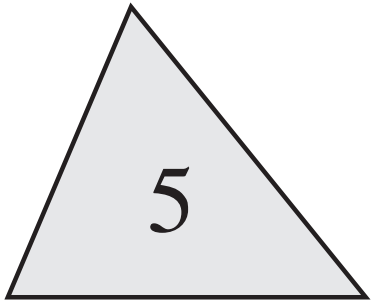
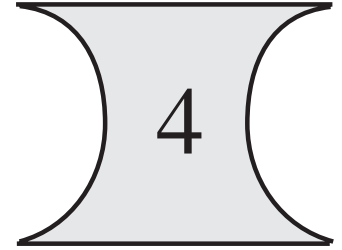
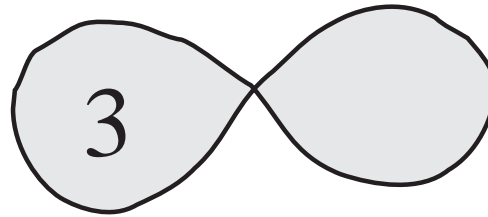
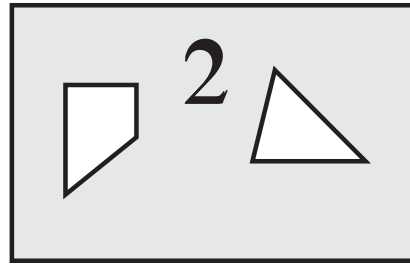
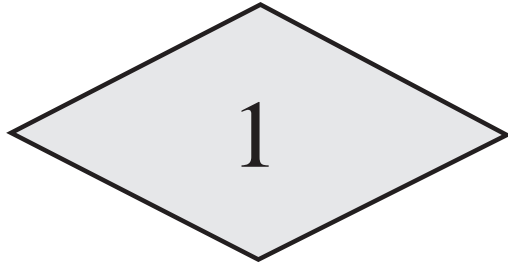

a)

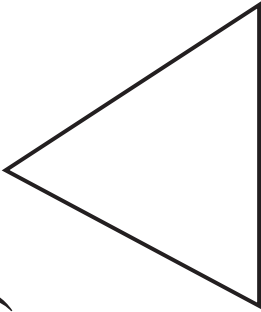

b)

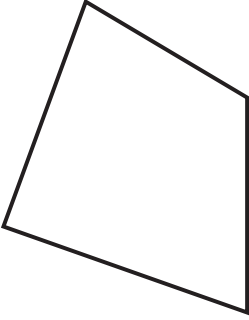

c)

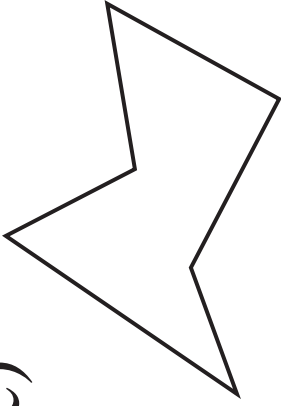

d)

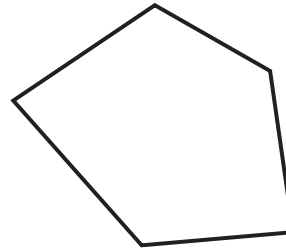

e)

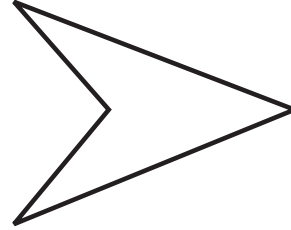

f)

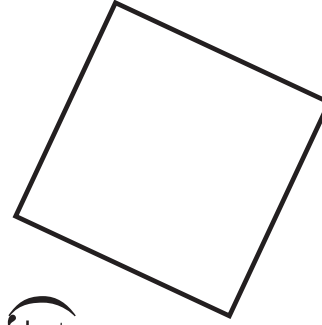

The image shows a large rectangular frame containing various geometric shapes. In the top-left corner, there is a small square box containing the letter 'S'. In the top-center, there is a small square box containing the letter 'P'. The shapes are distributed as follows:

- Top row: A crescent moon, a trapezoid with a circle and a square inside, a teardrop shape, an oval, and a triangle with a diagonal line.
- Left side: A circle, a figure-eight, and a shape with two inward-curving sides.
- Center: A box with the letter 'P', a pentagon, a triangle, a diamond, a hexagon, a square, a diamond, and a crown.
- Right side: A triangle with a diagonal line, a diamond, and another diamond.
- Bottom row: A shape with a wavy top, a semi-circle, and a teardrop shape.

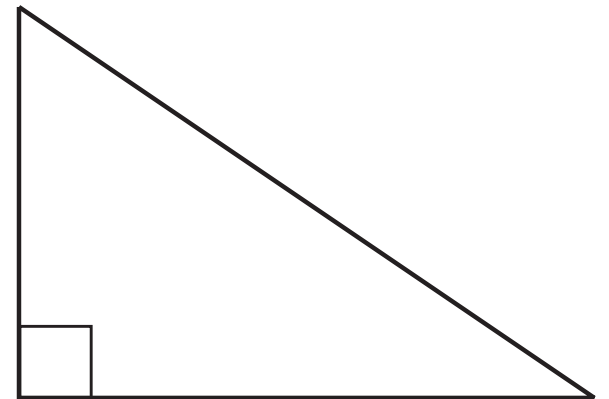
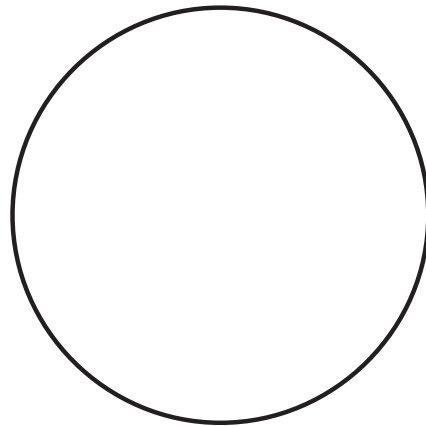
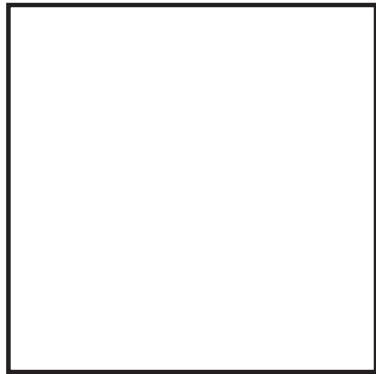
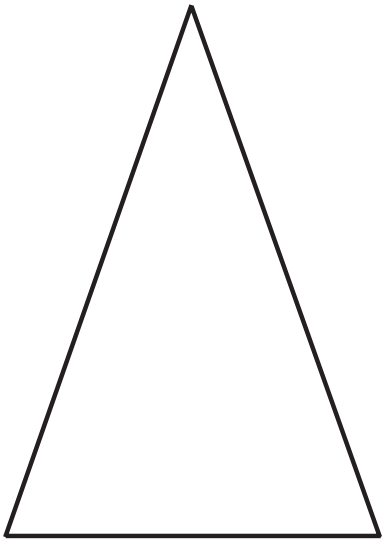
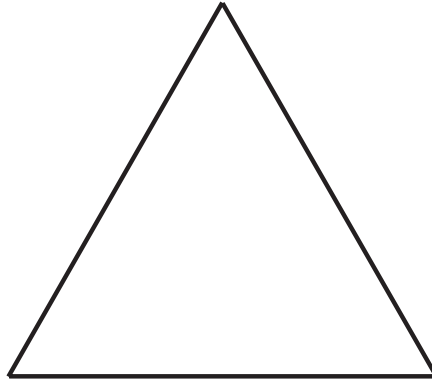
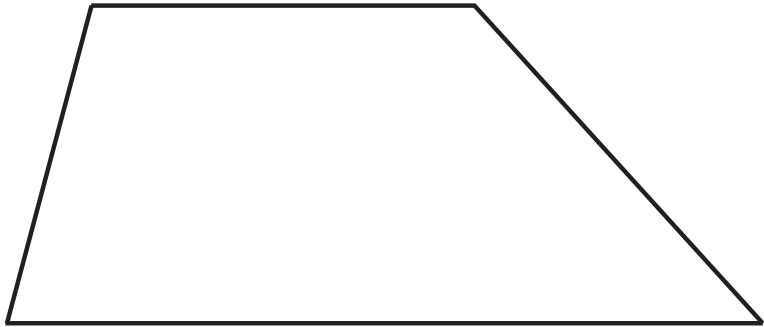

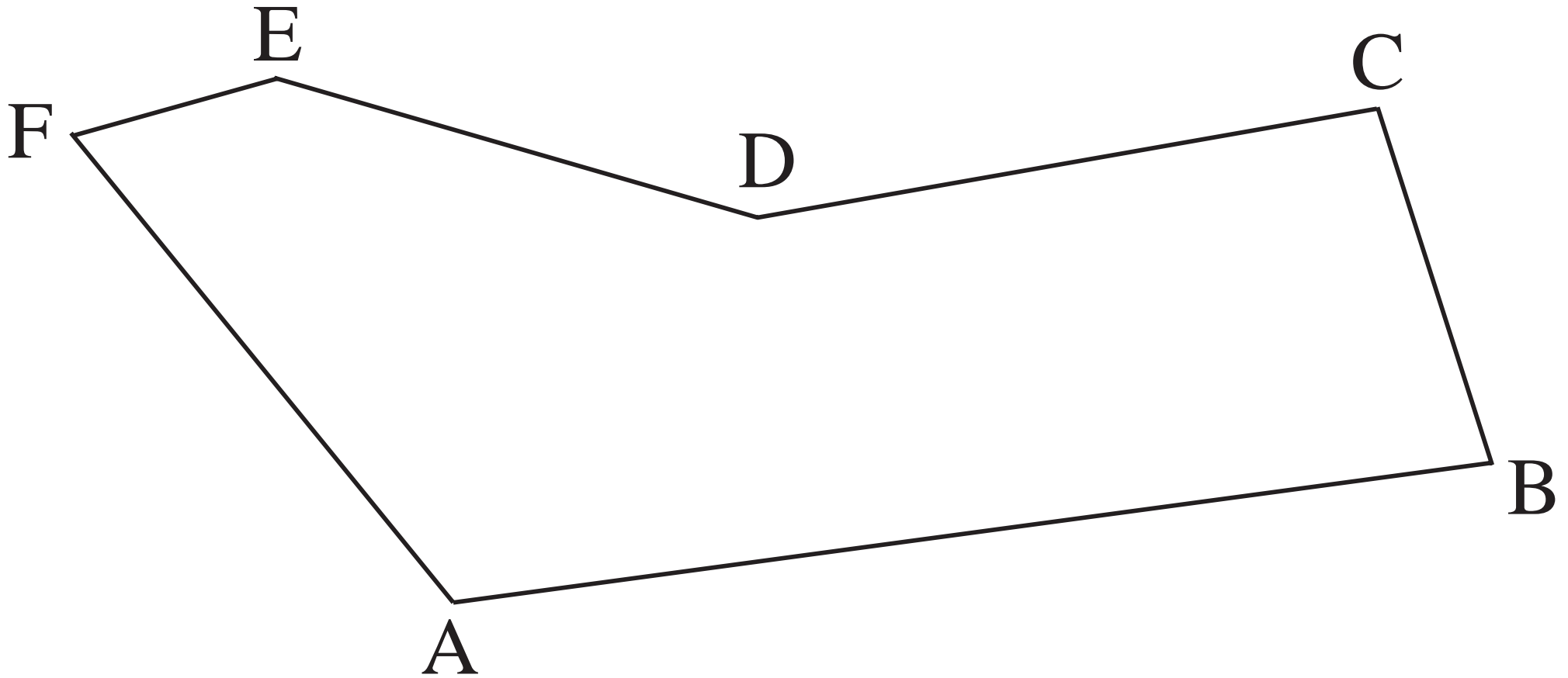

AB =

BC =

CD =

DE =

EF =

FA =

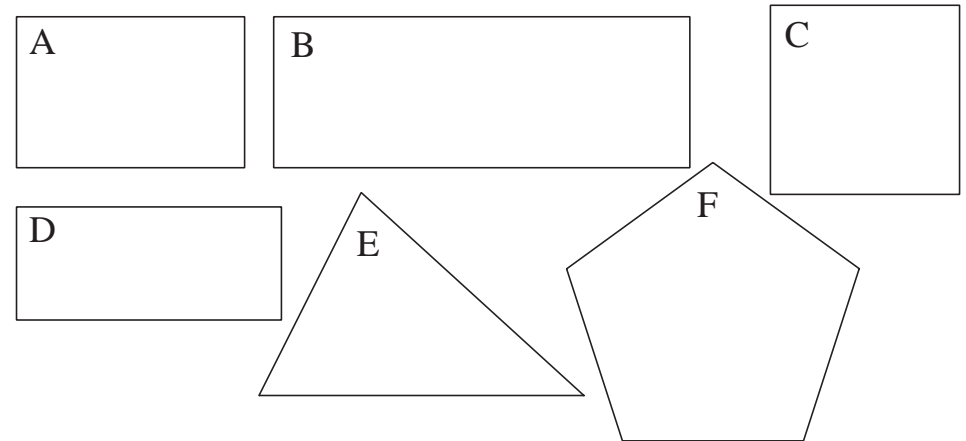
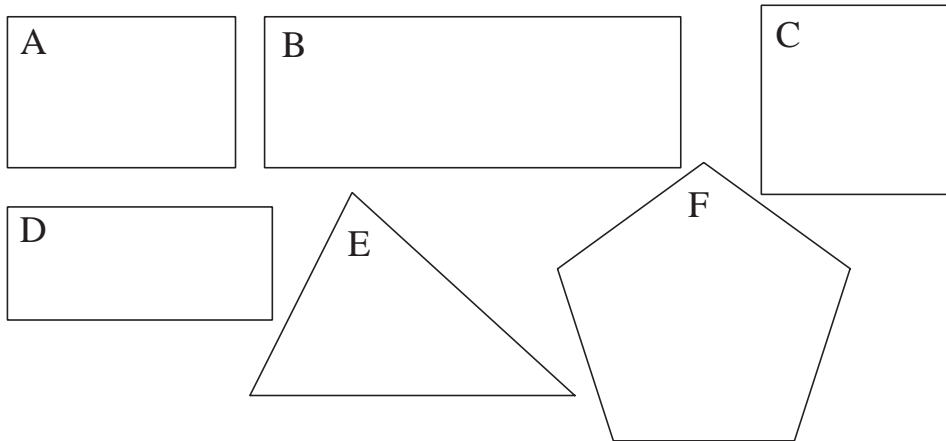
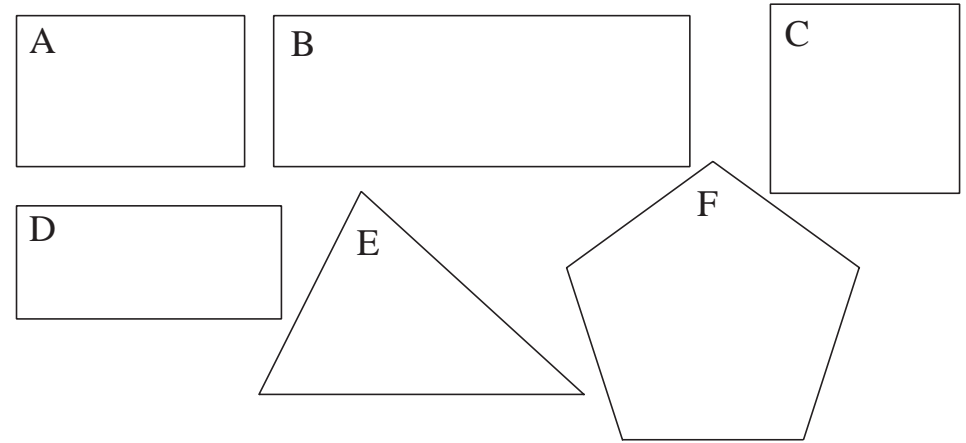
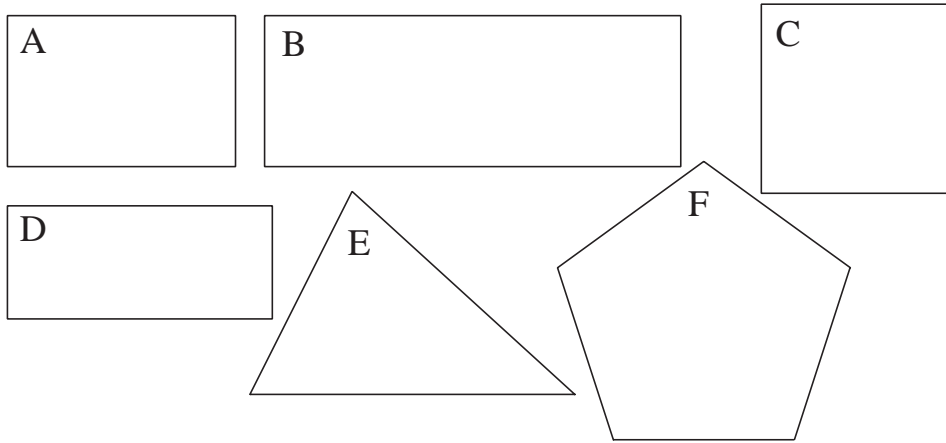
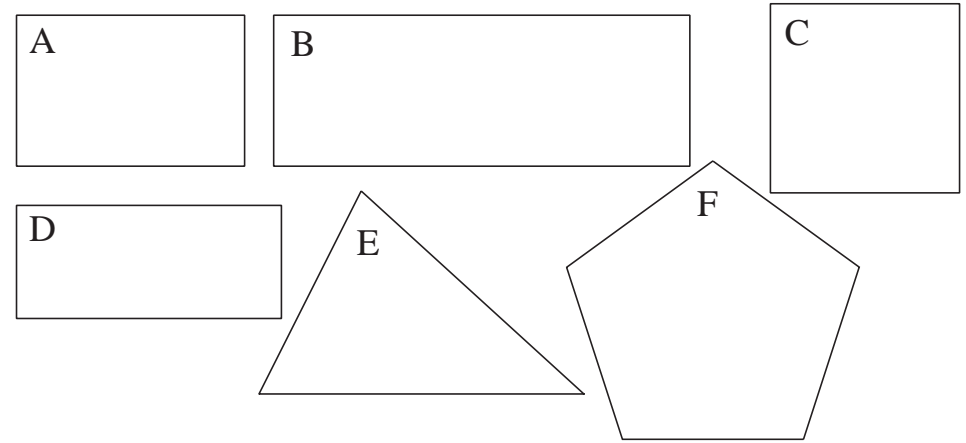
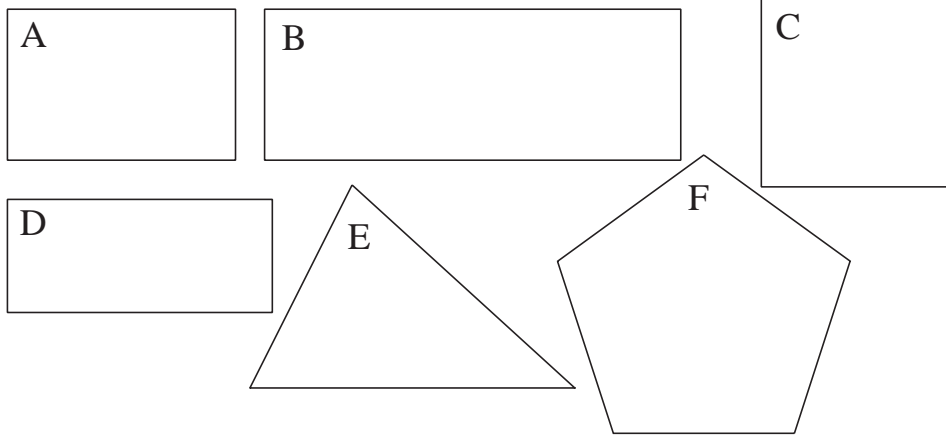

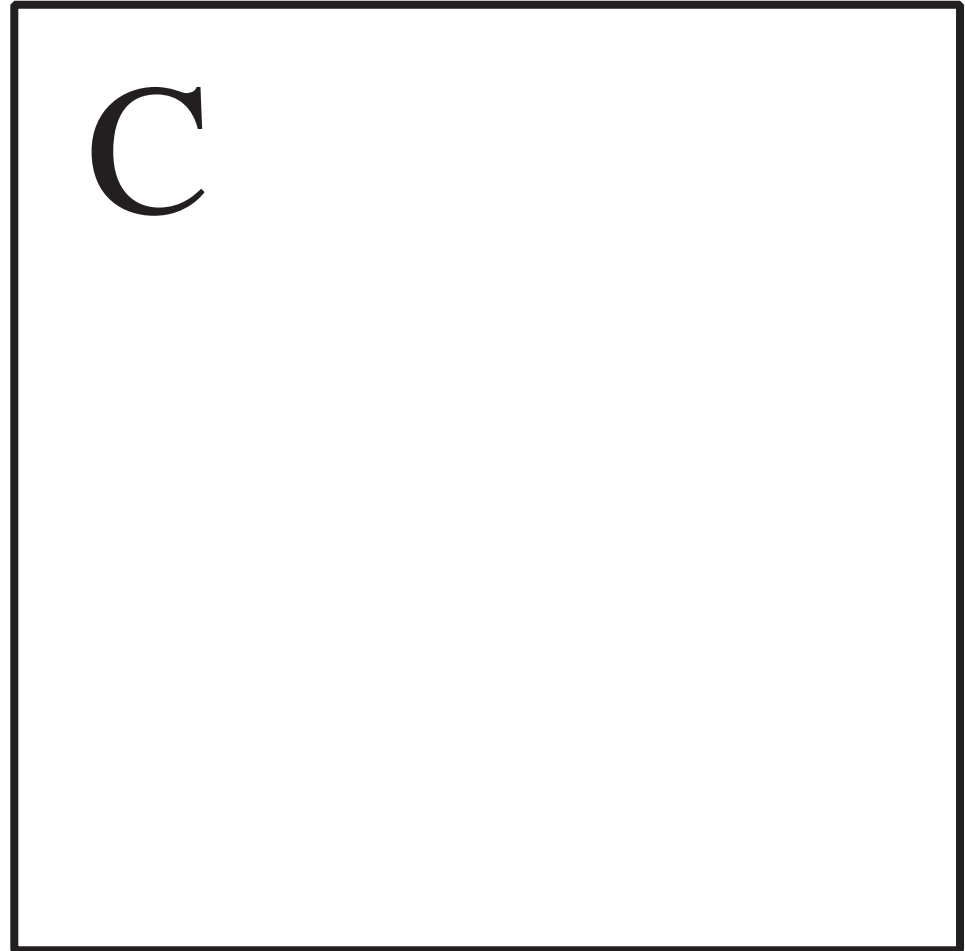
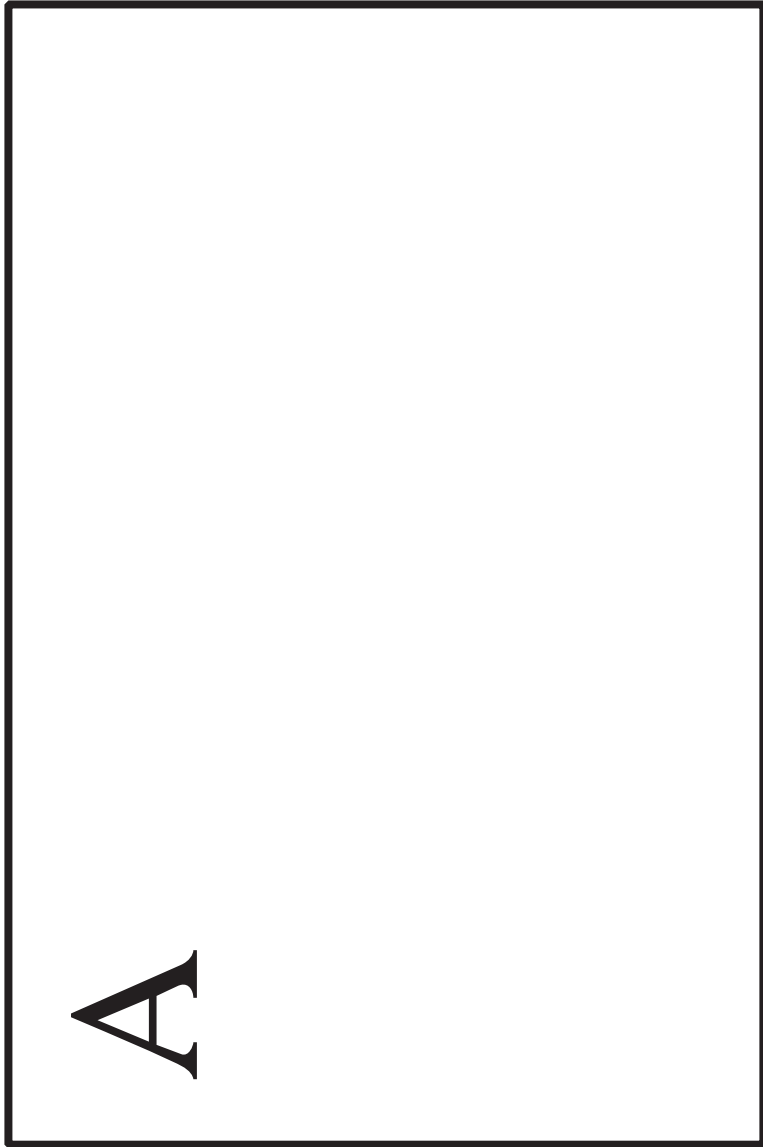

B

D

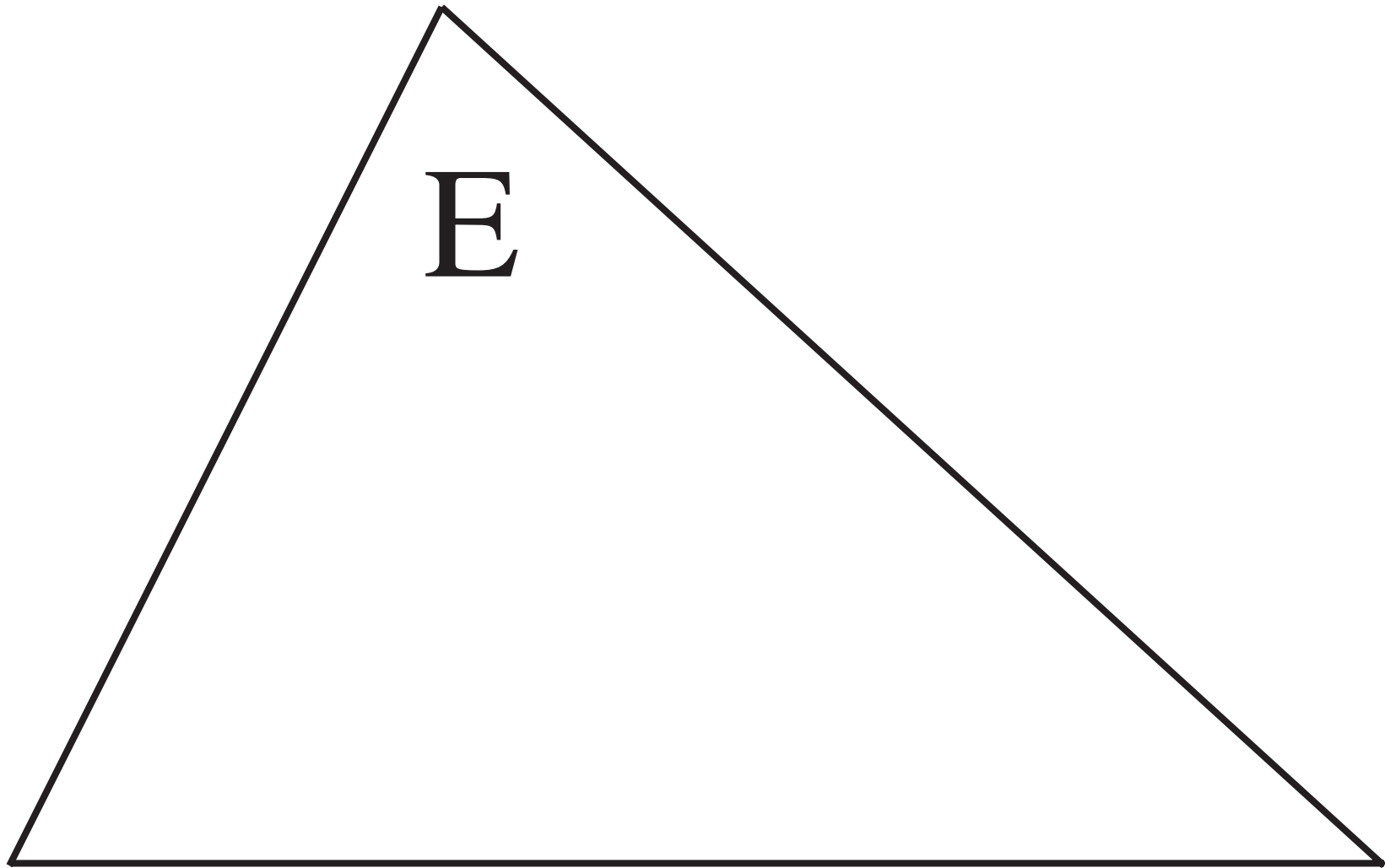

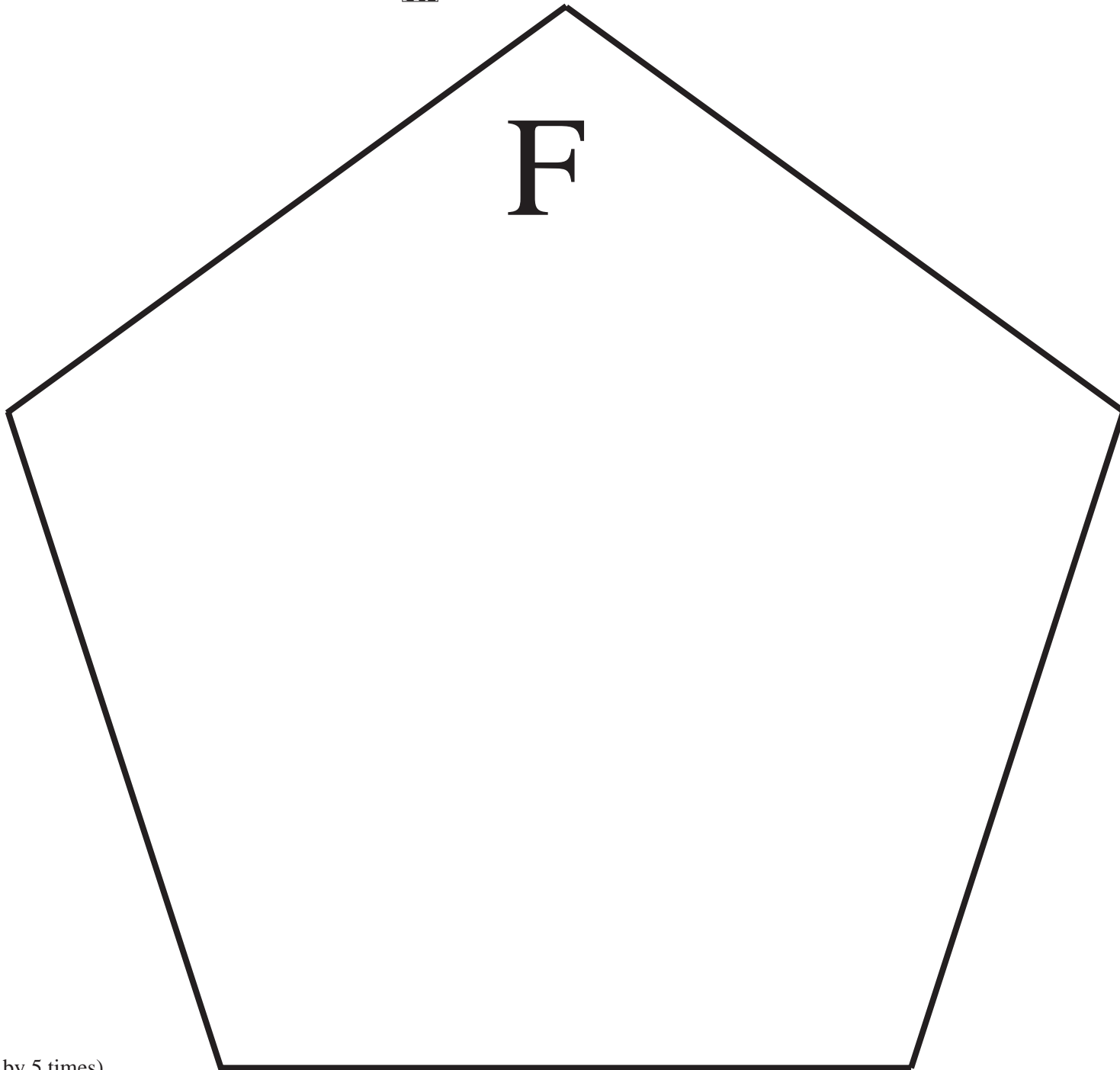

a)

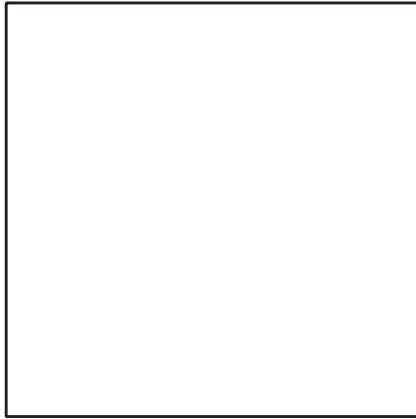

$$P =$$

b)

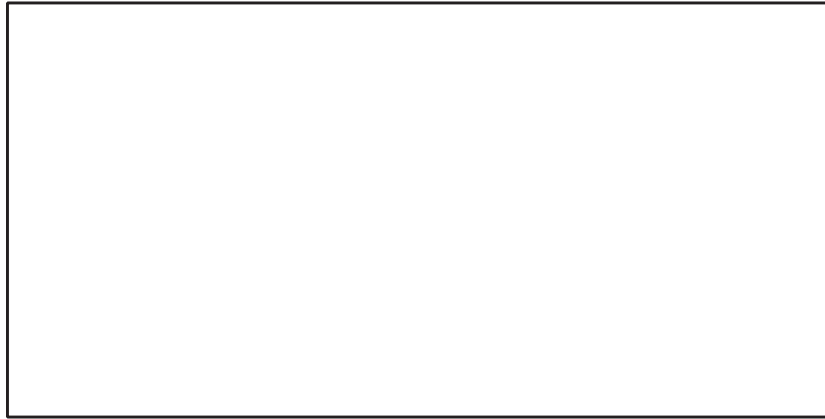

$$P =$$

c)

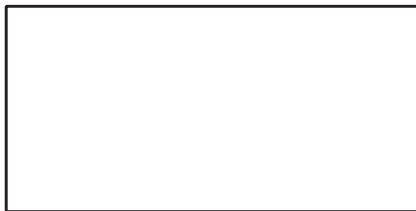

$$P =$$

d)

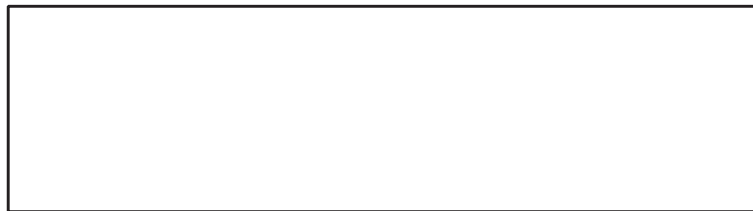

$$P =$$

e)

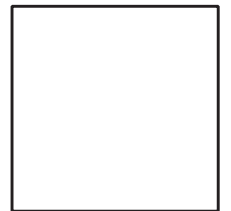

$$P =$$

a)

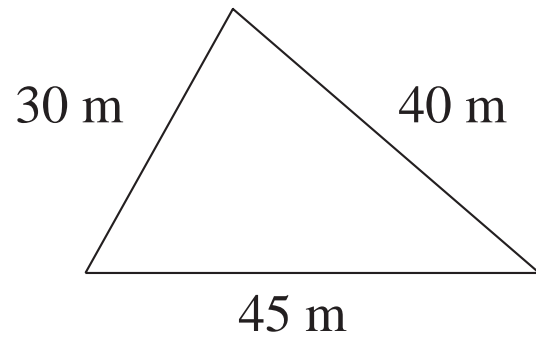

$$P =$$

b)

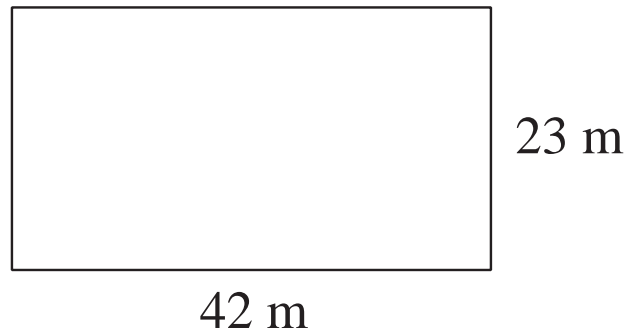

$$P =$$

c)

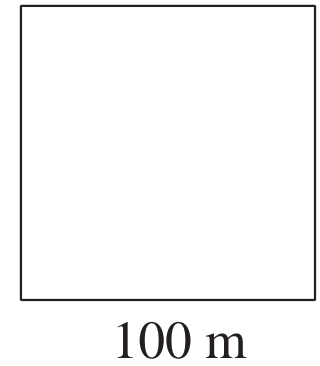

$$P =$$

LP 43/7

a)

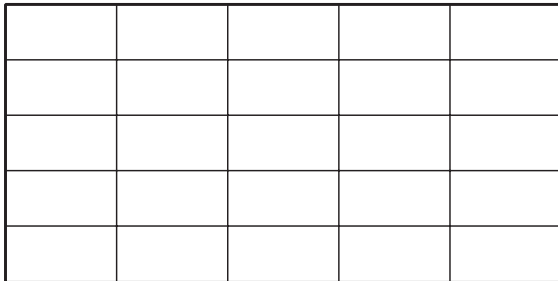
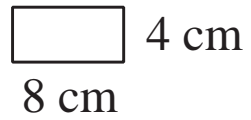

b)

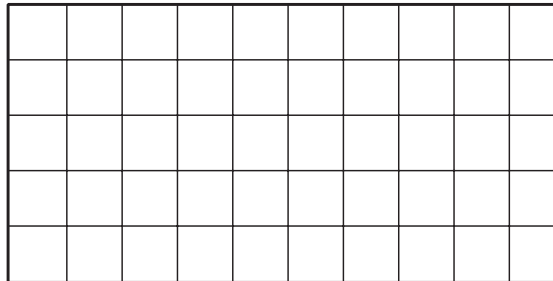
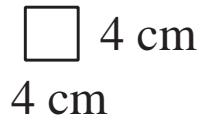

c)

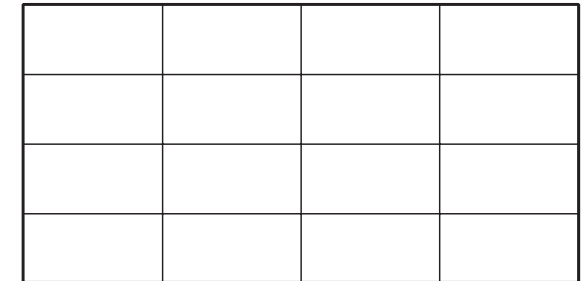
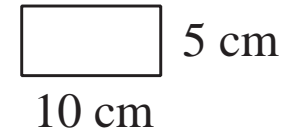

LP 44/3

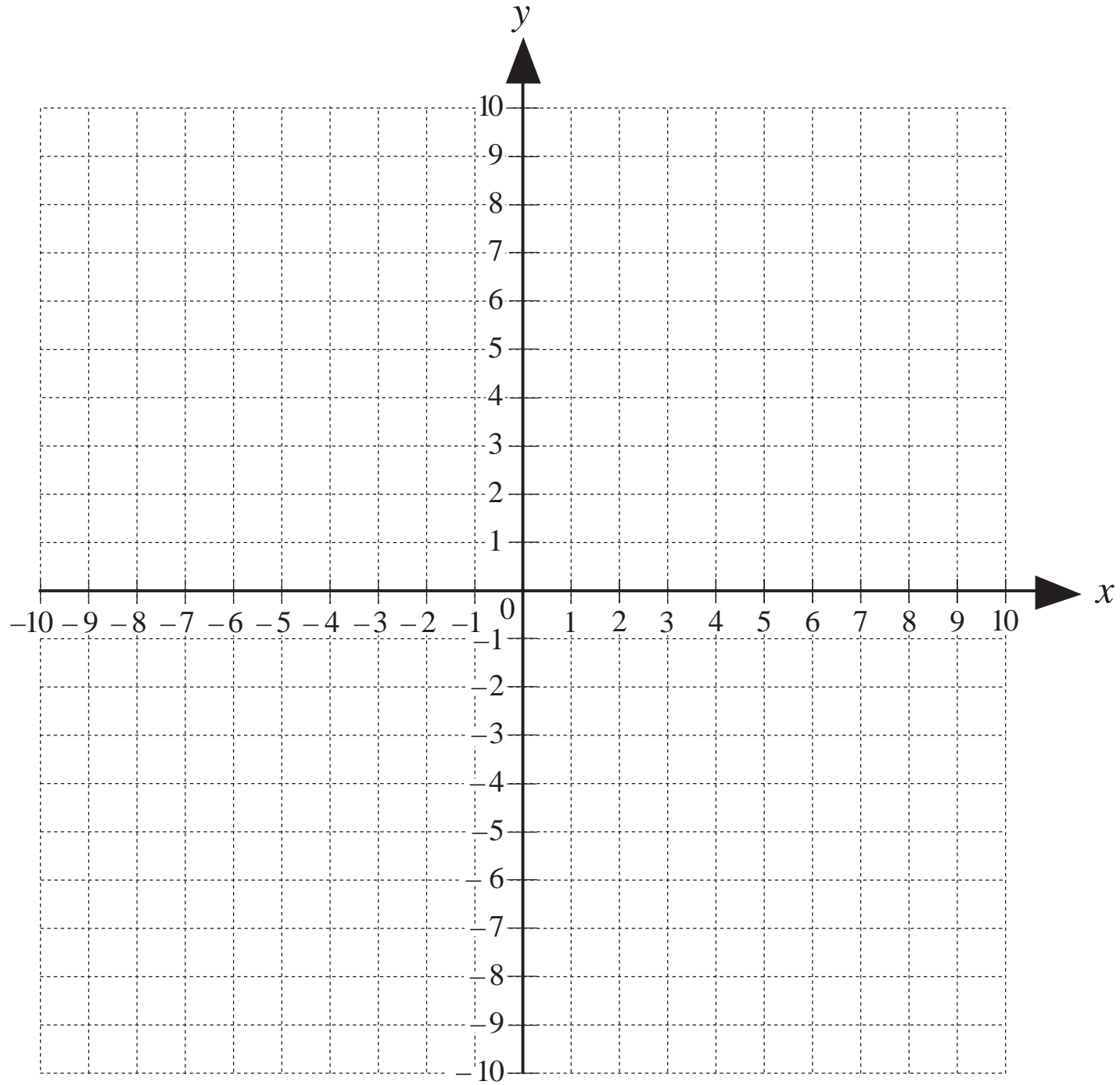

a)

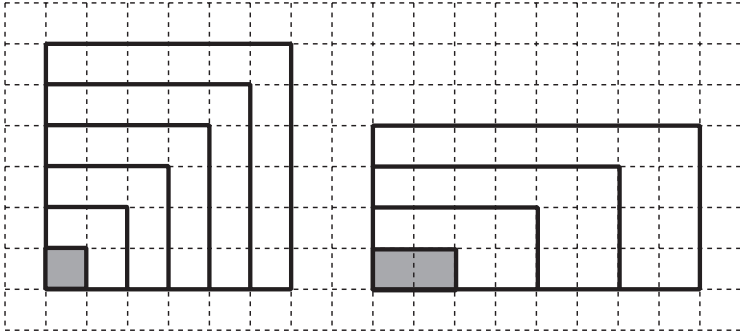

b)

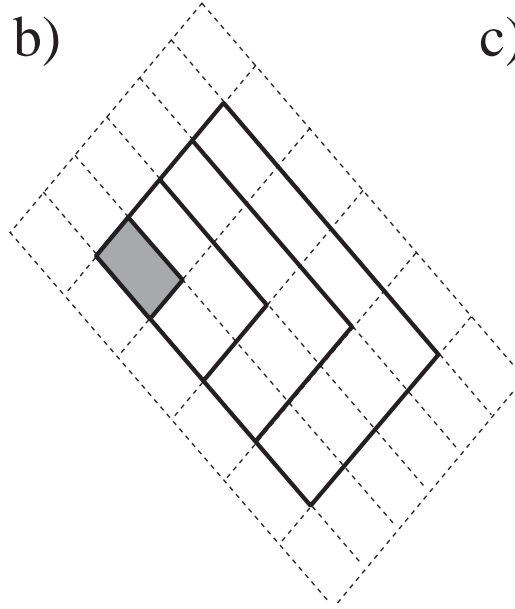

c)

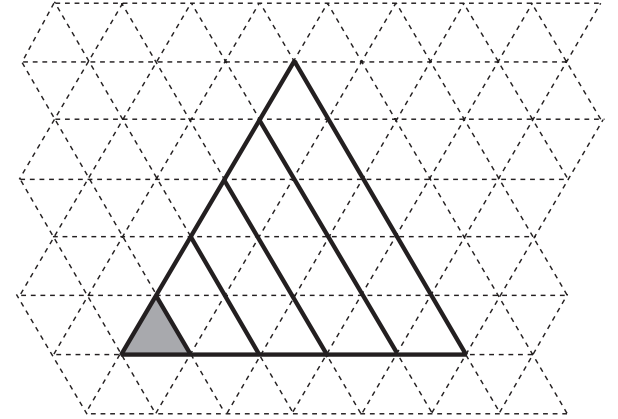

d)

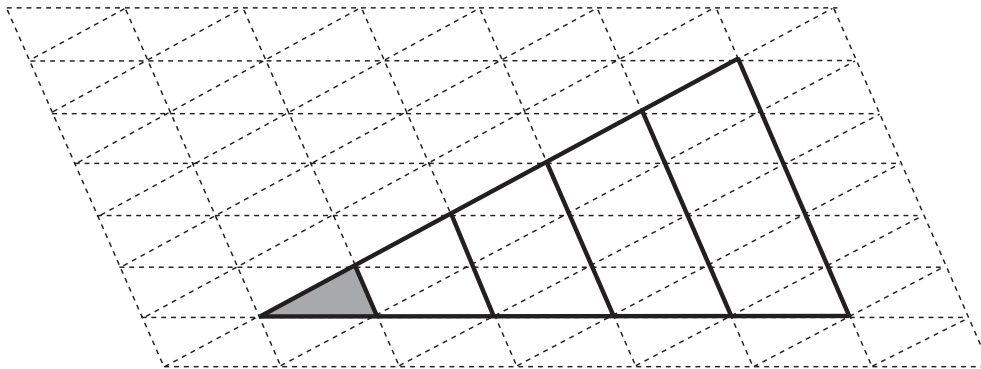

e)

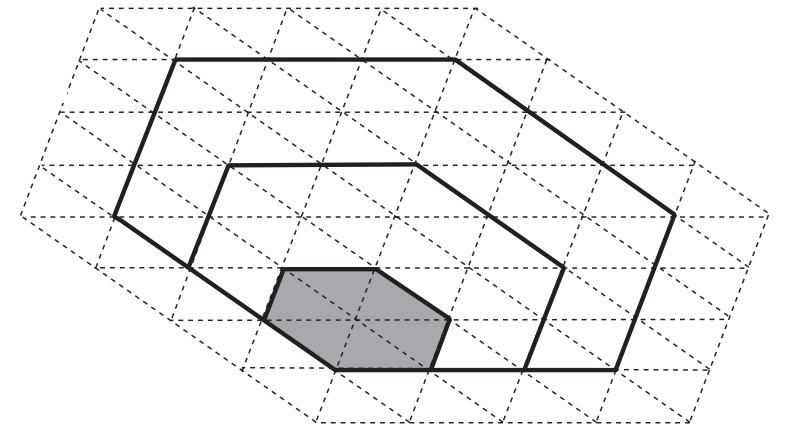

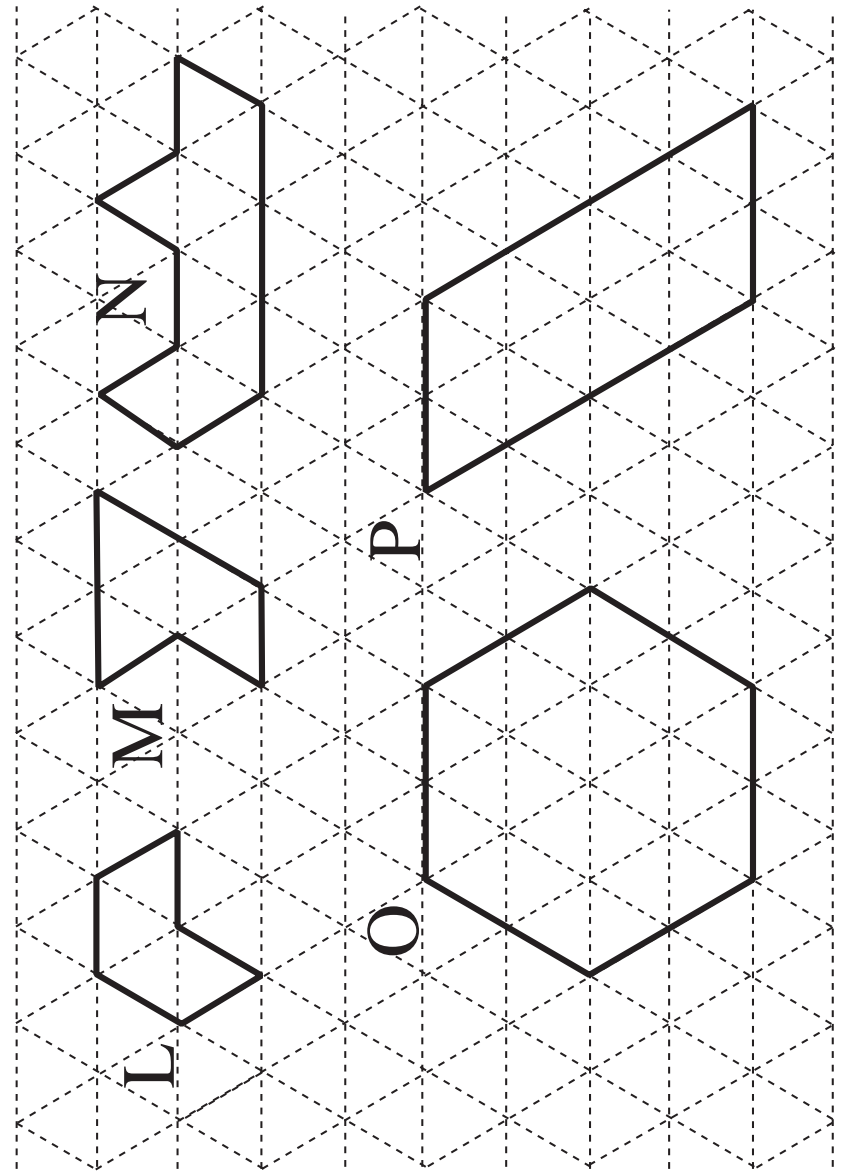
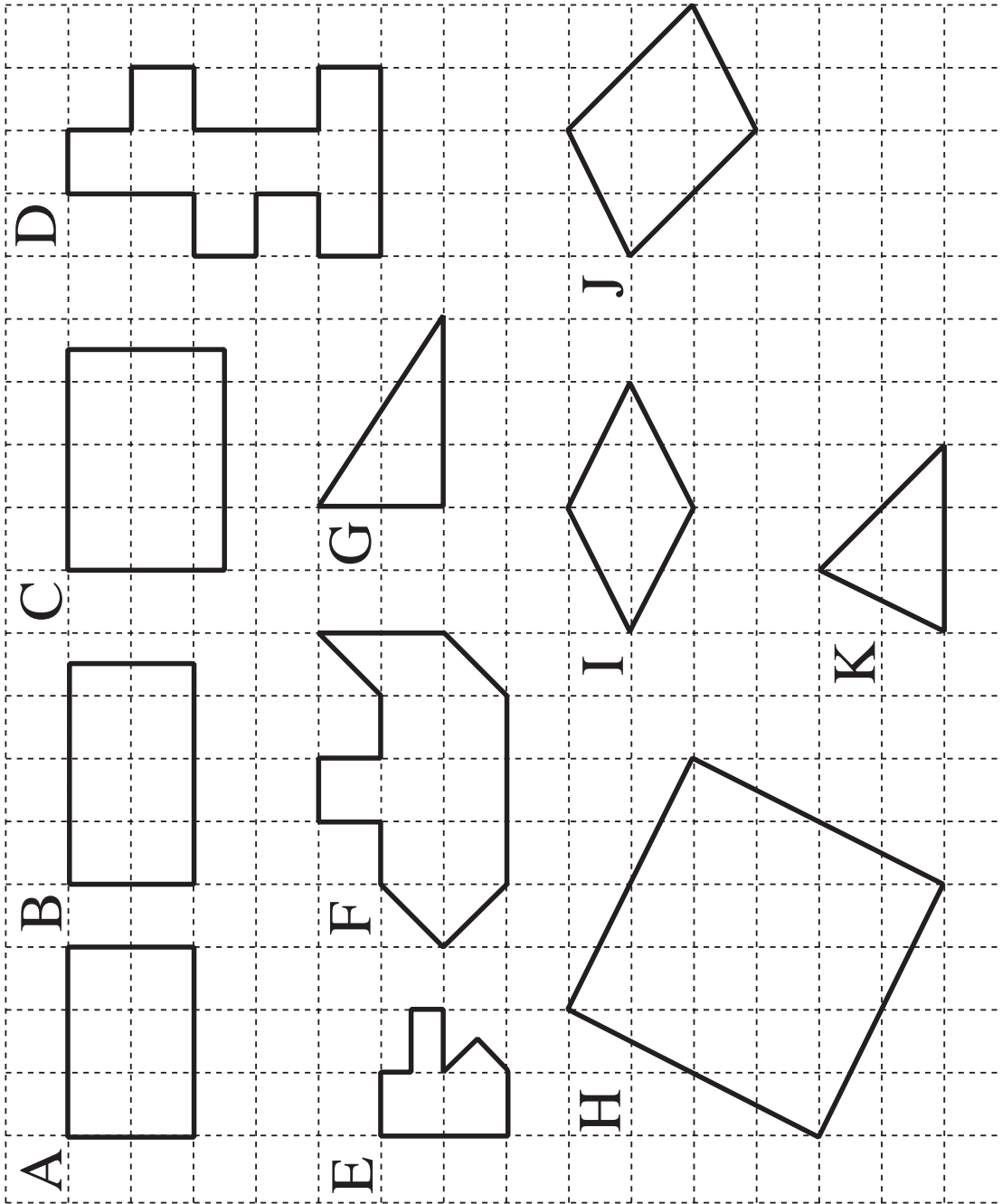

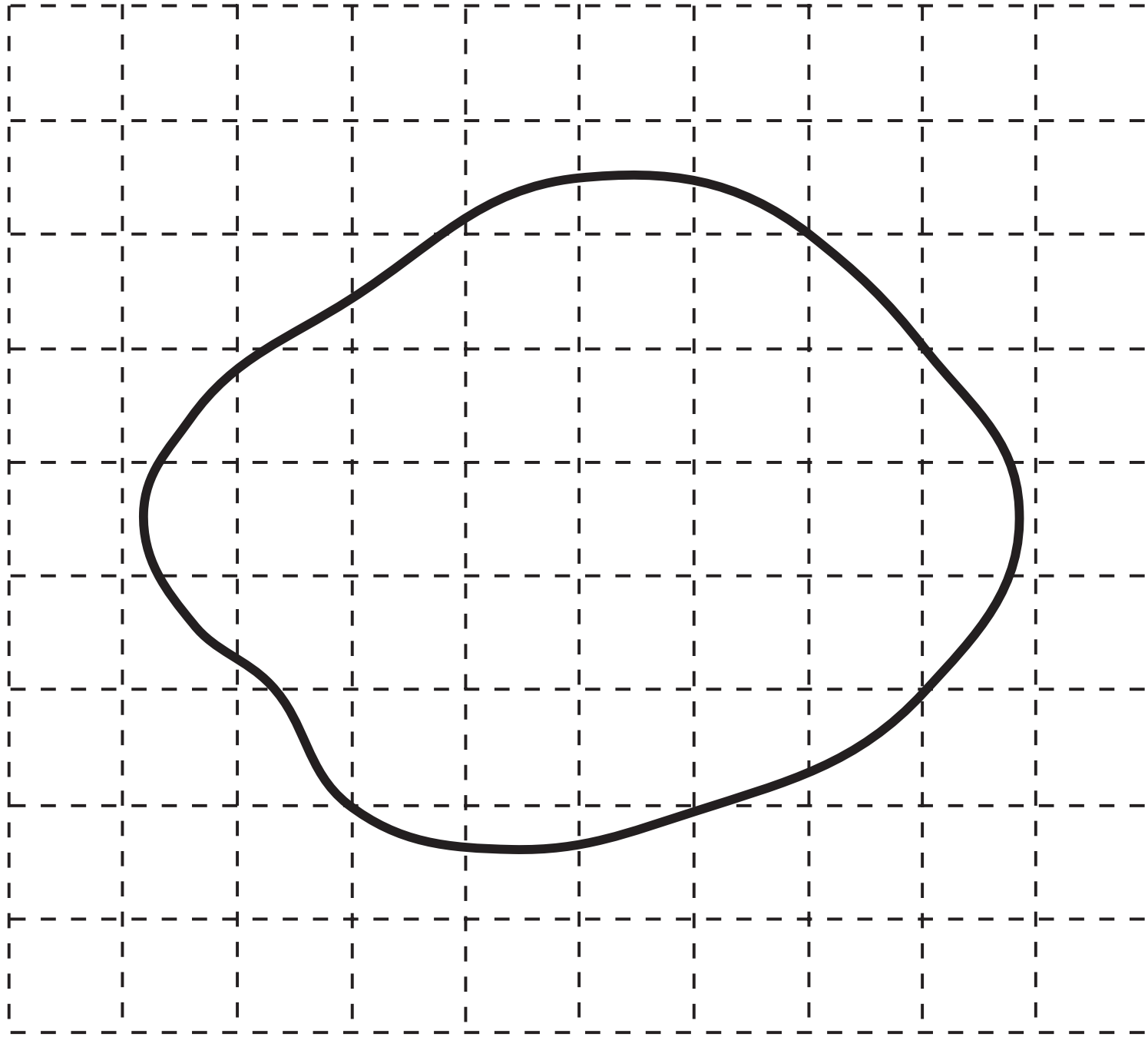

<i>a</i>	5	3	4		6	17		8	12
<i>b</i>	9	7	6	4		7	9	8	
<i>P</i>	28			56	126		135		144

Rule: P =

LP 45/1

<i>a</i>	1	2	3	4	5	6	7	8	9
<i>b</i>									

LP 45/3

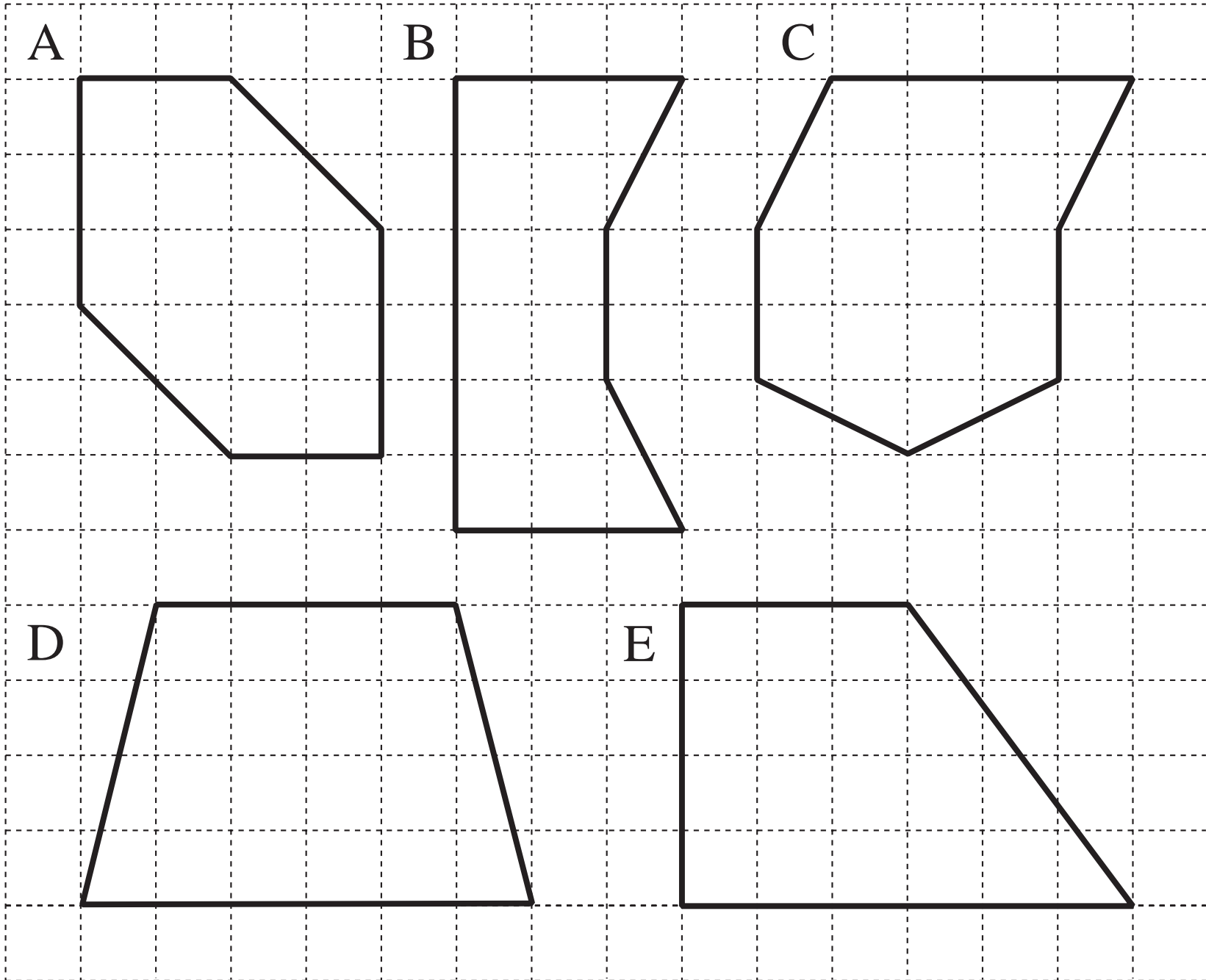

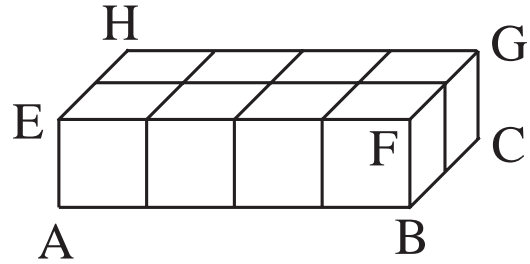

ABCD =

EFGH =

ABFE =

DCGH =

ADHE =

BCGF =

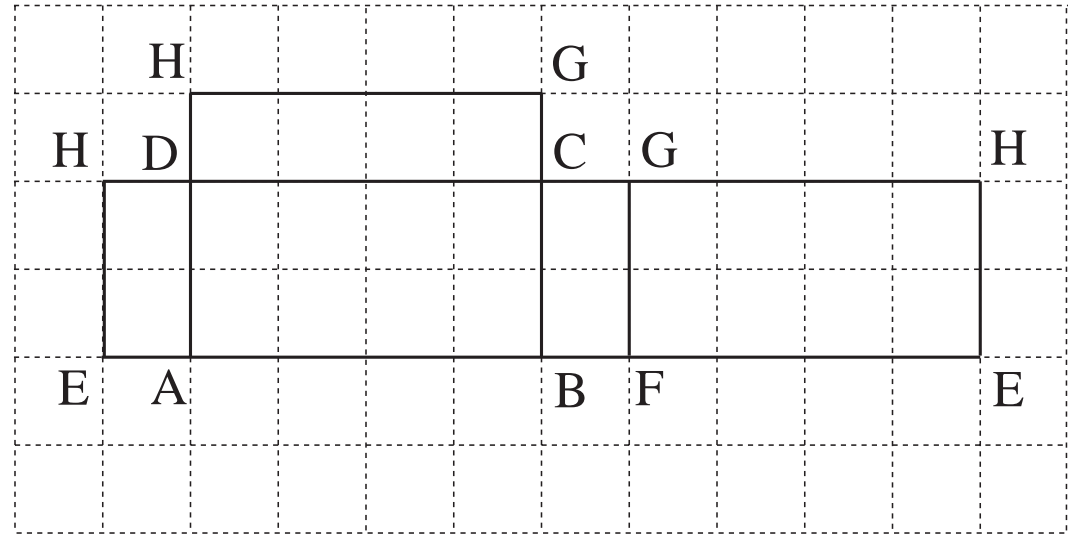

Total area =

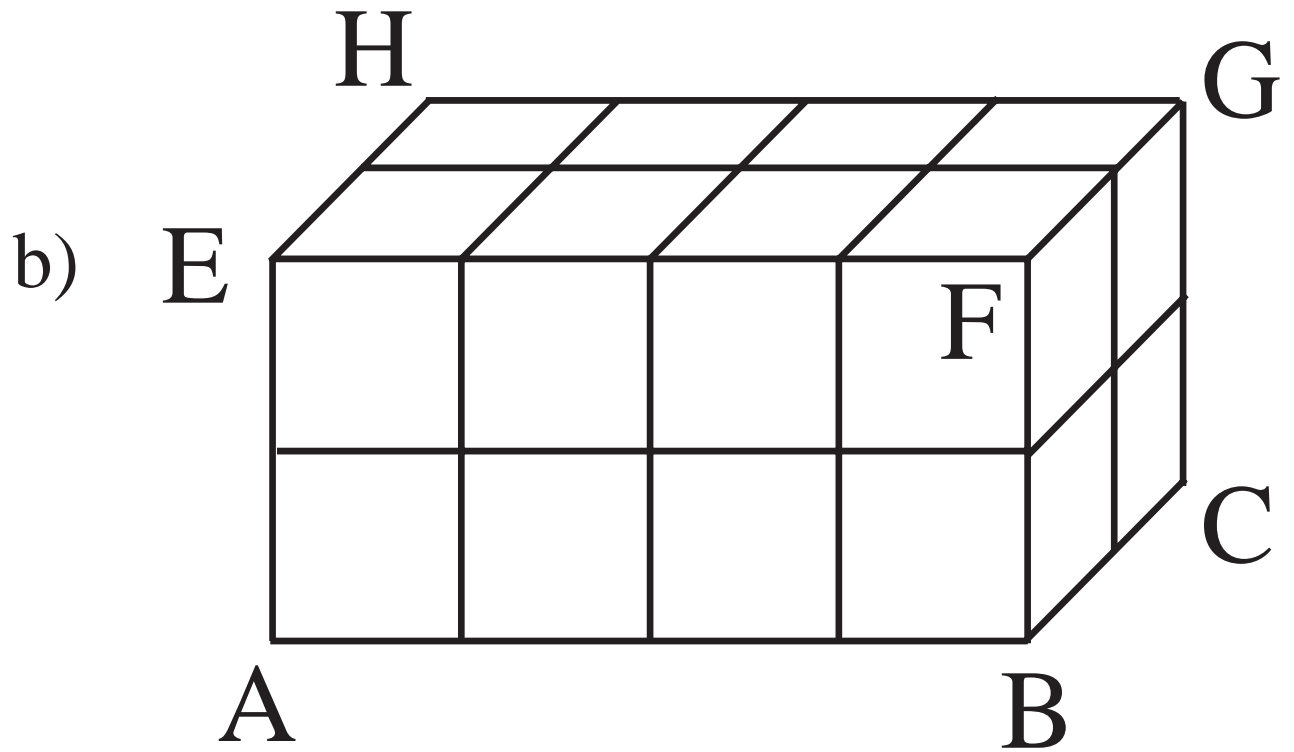
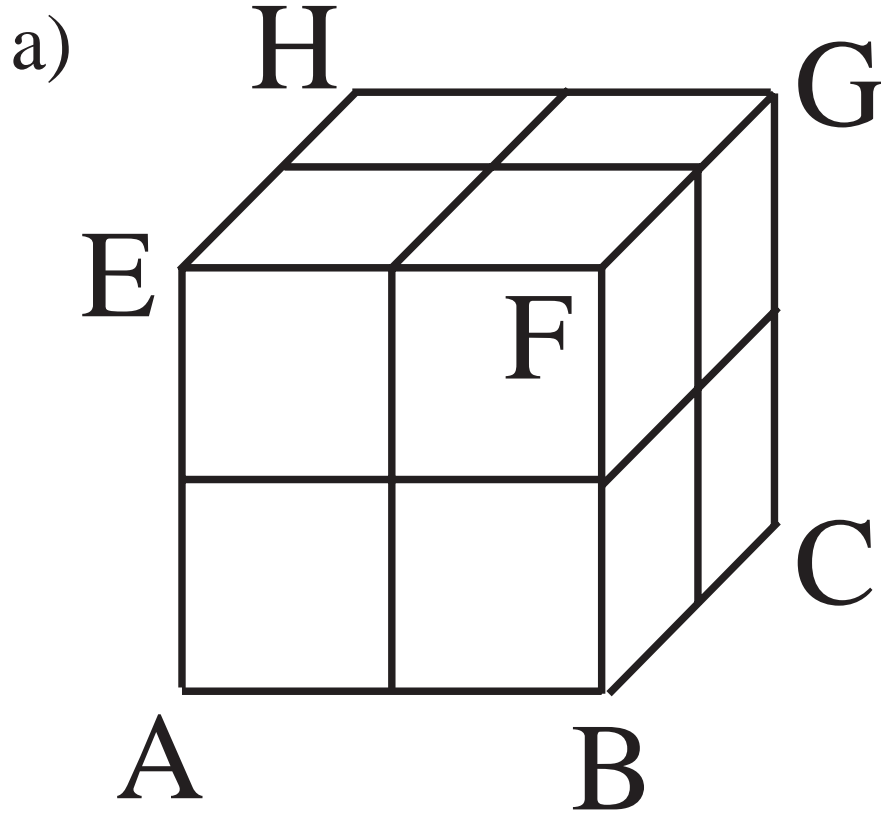

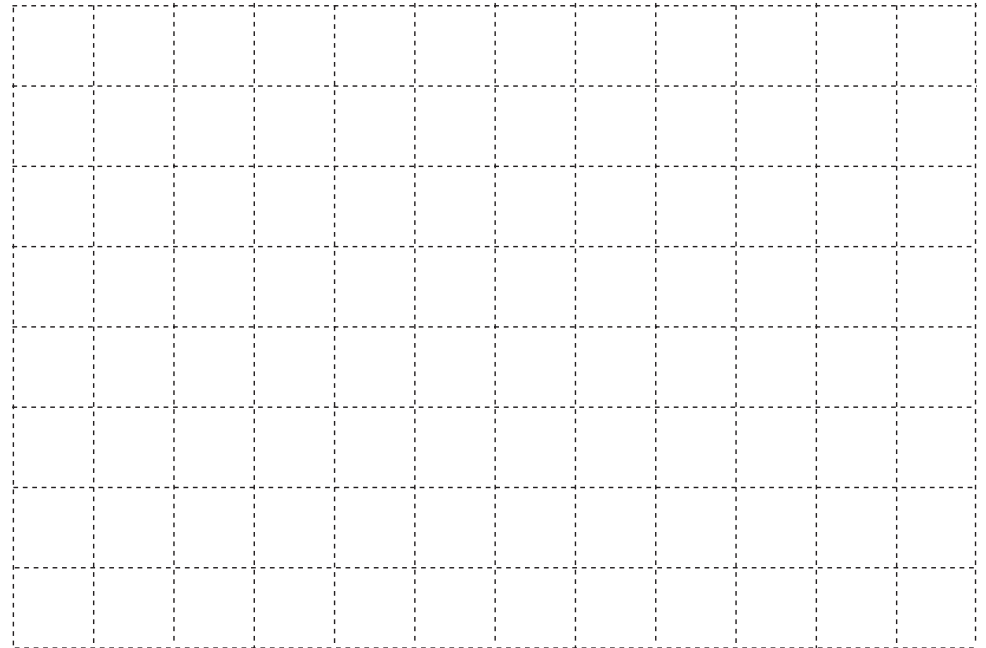
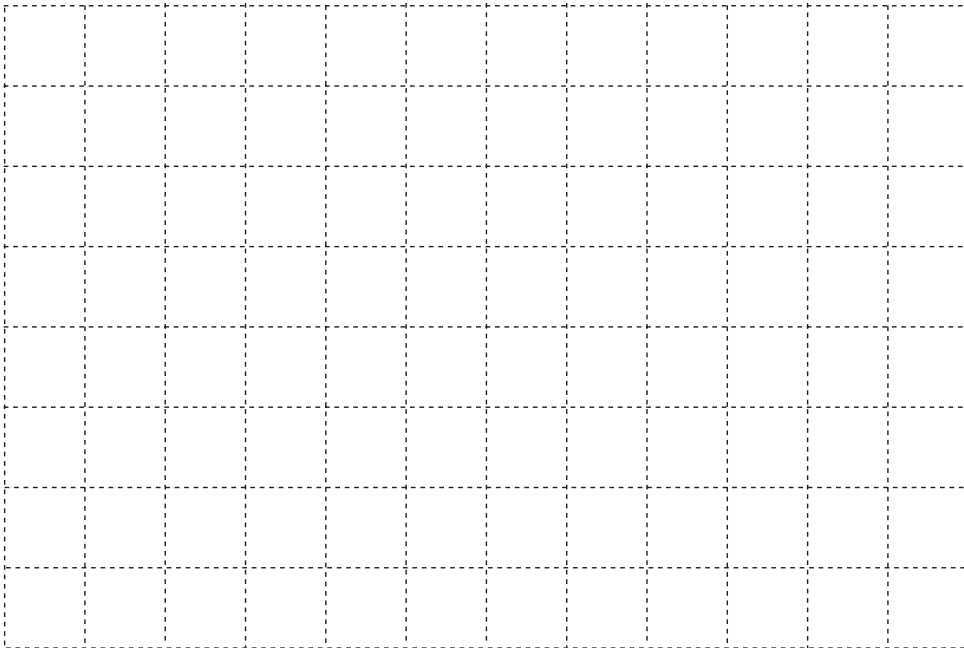
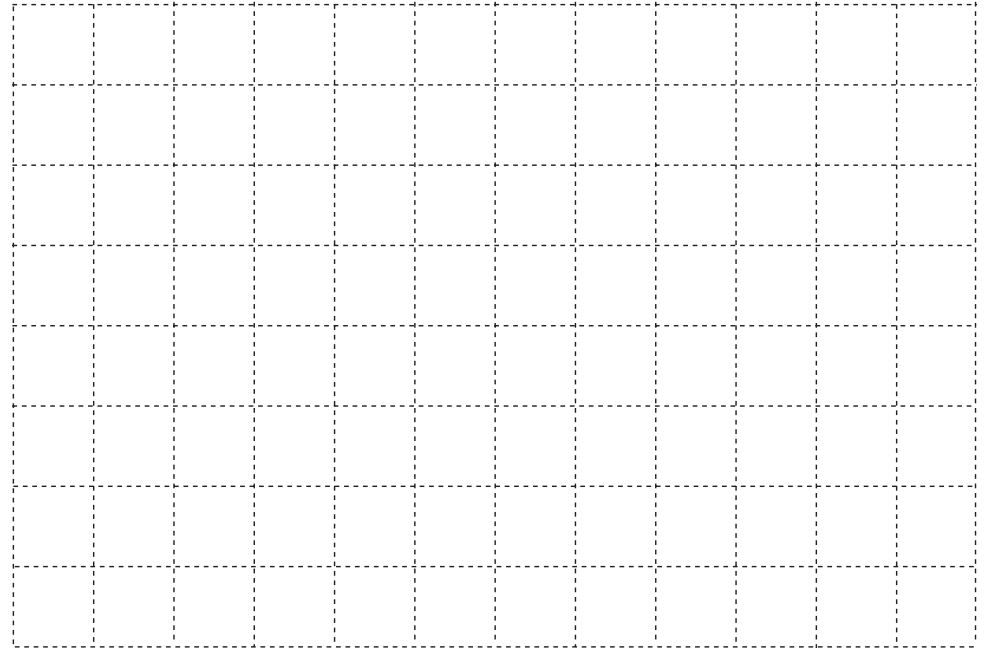
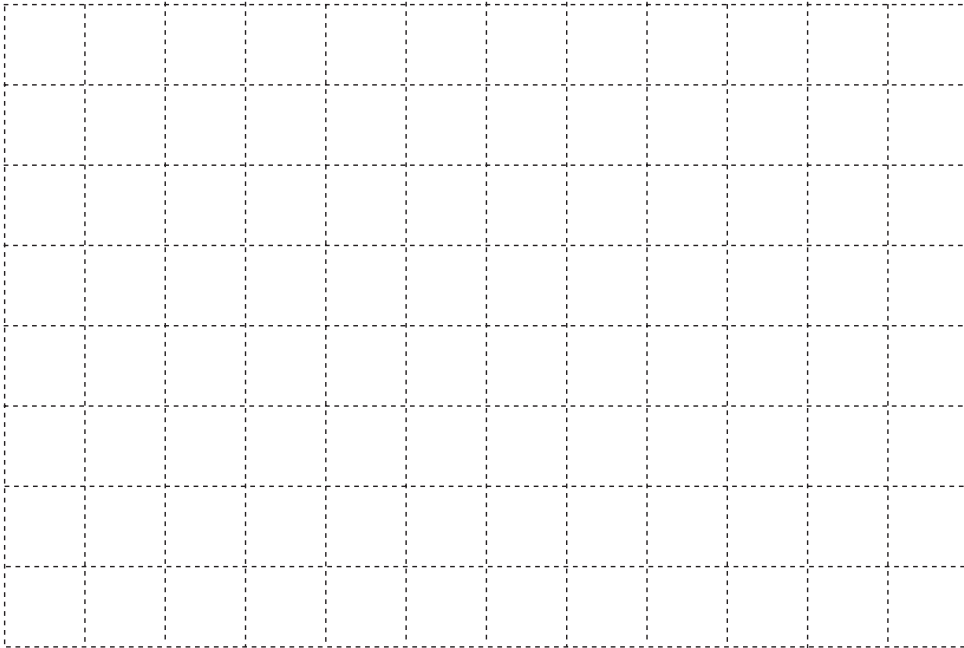

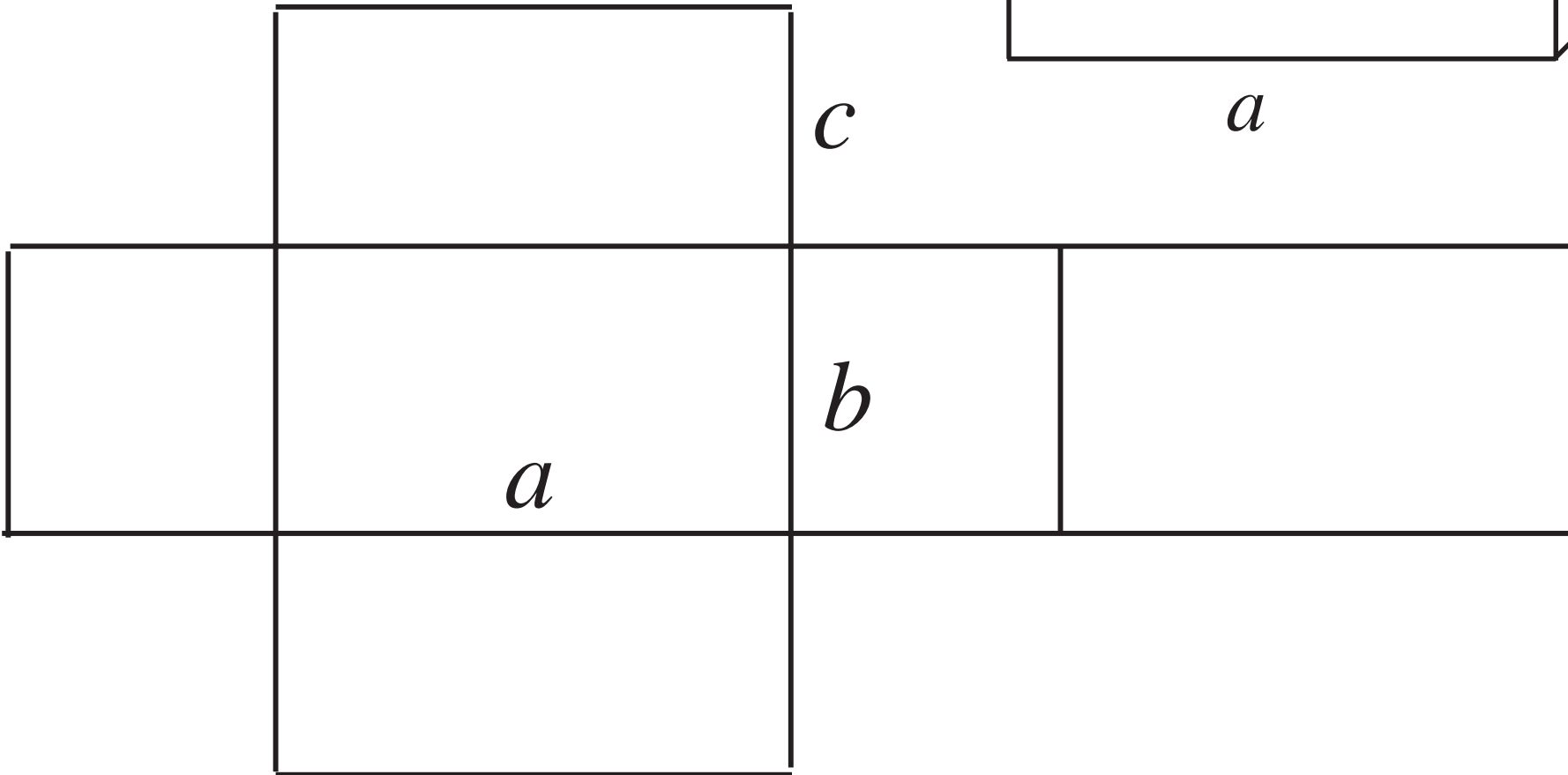
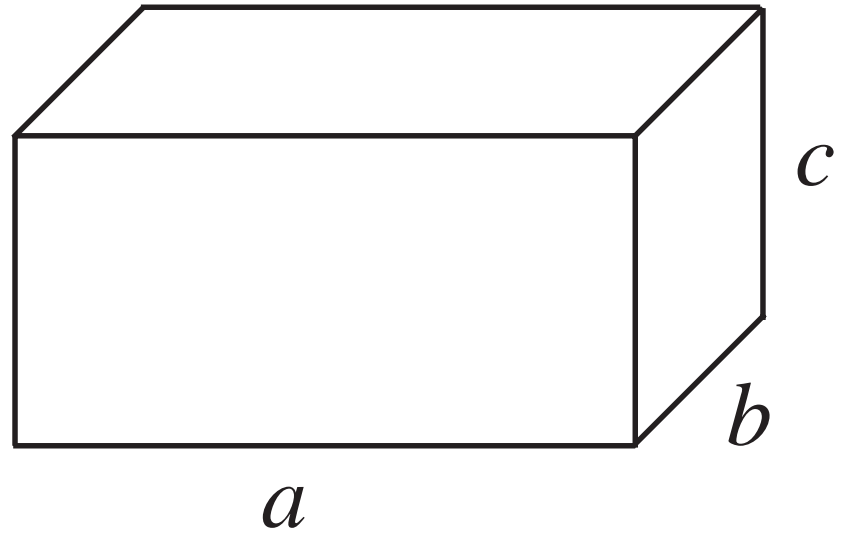

a)

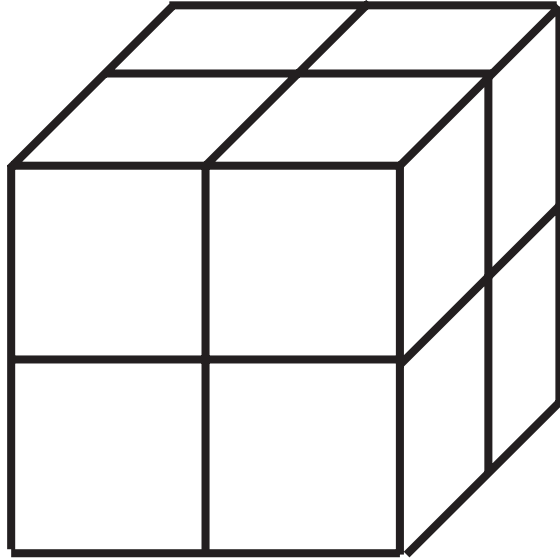

unit cubes

b)

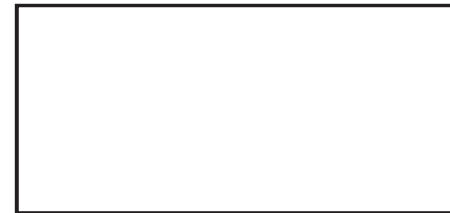
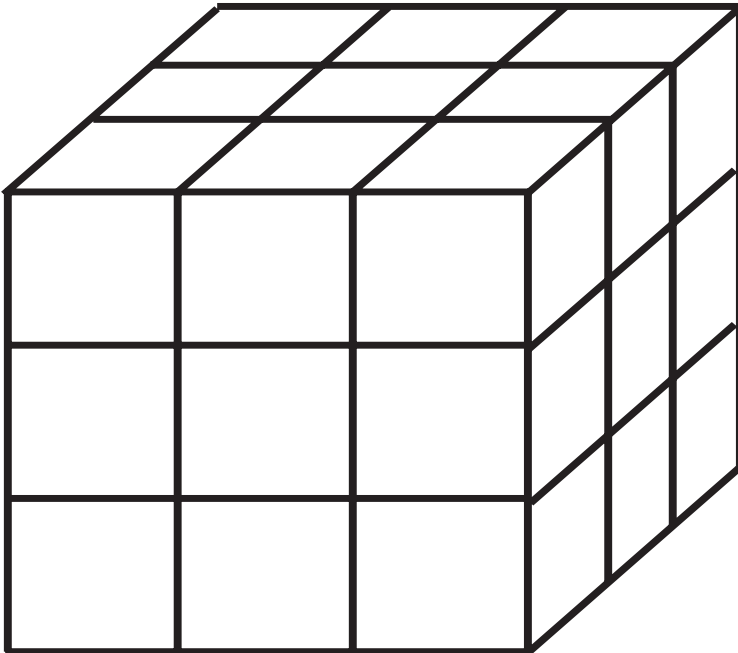

unit cubes

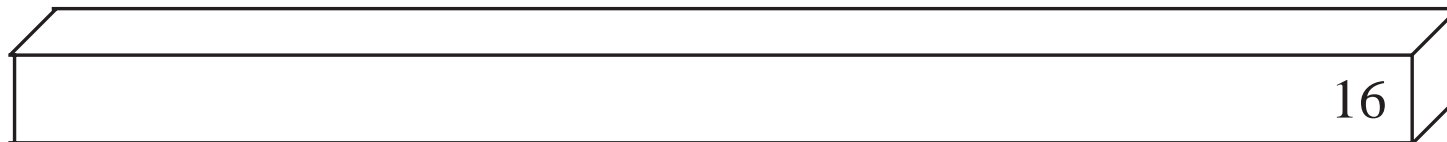
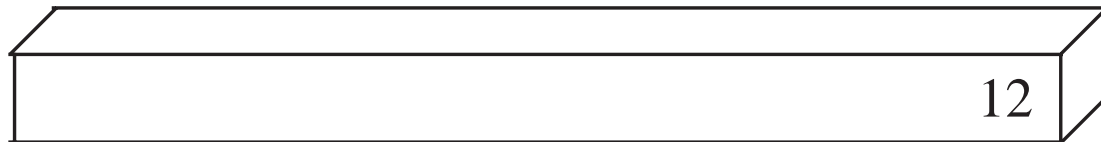
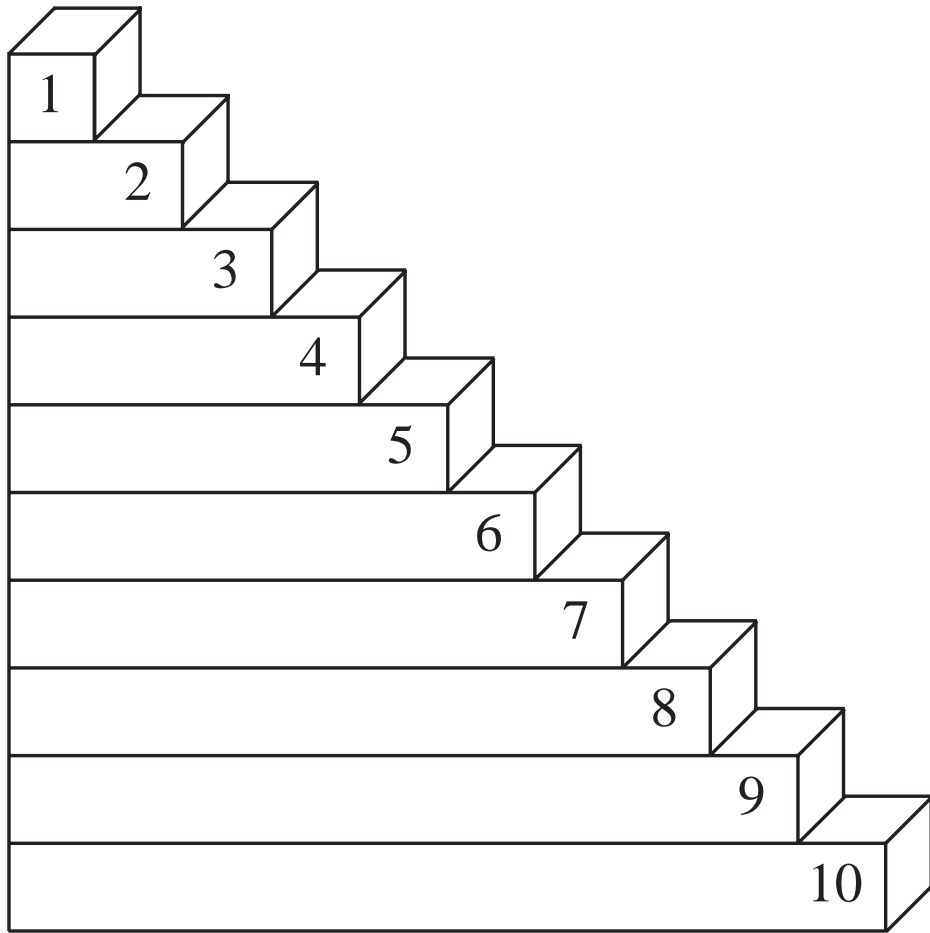

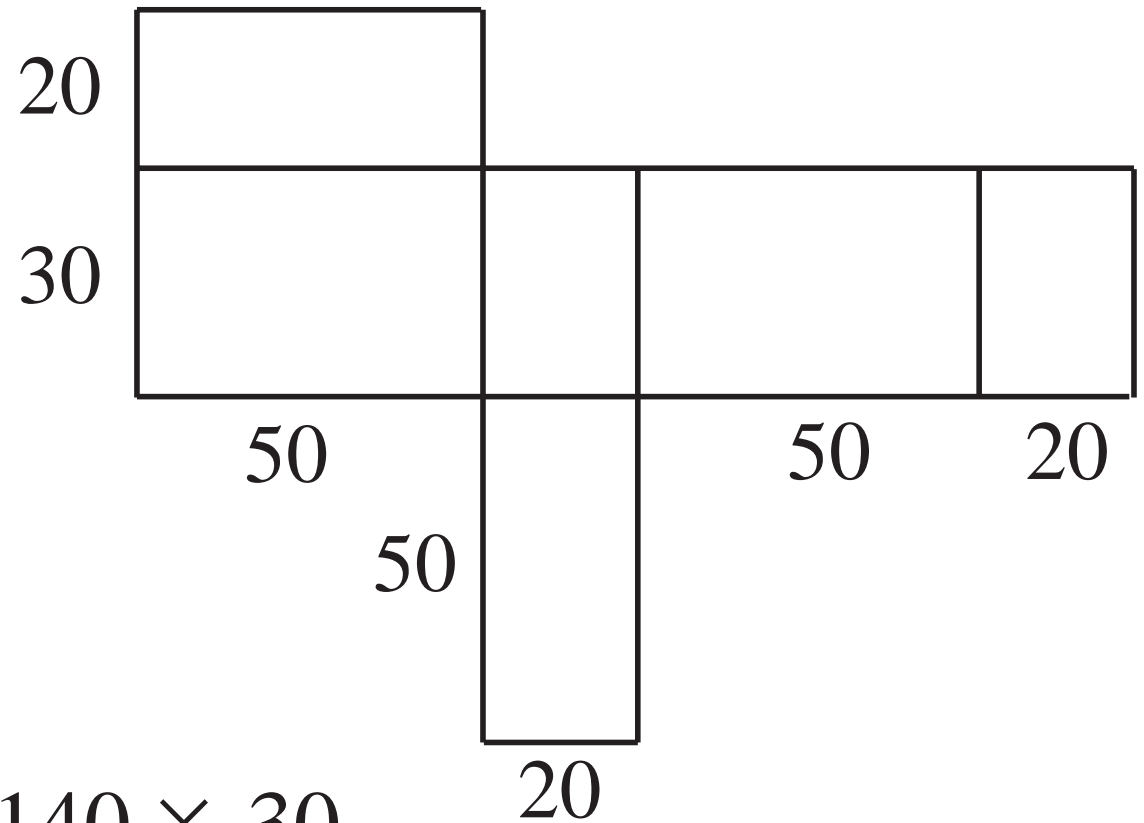
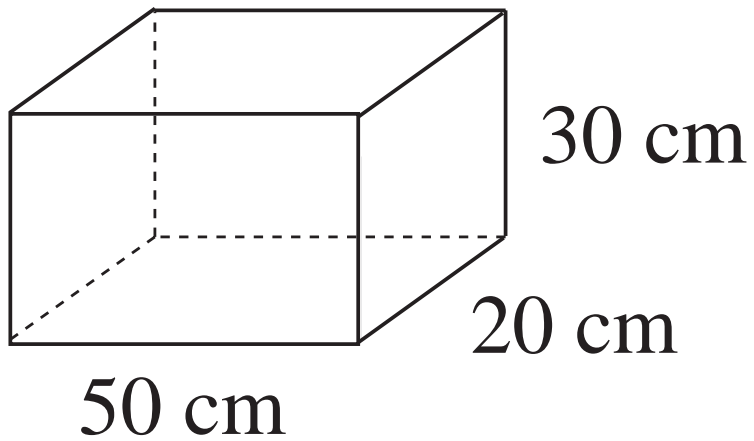

$$\begin{aligned} A &= 2 \times (50 \times 20) + 140 \times 30 \\ &= 2 \times 1000 + 4200 \\ &= 2000 + 4200 \\ &= \underline{6200 \text{ (cm}^2\text{)}} \end{aligned}$$

a)

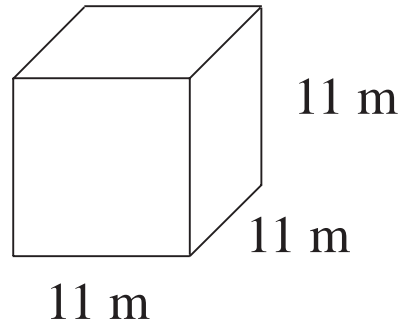

$$A = \text{-----}$$
$$\text{-----}$$

b)

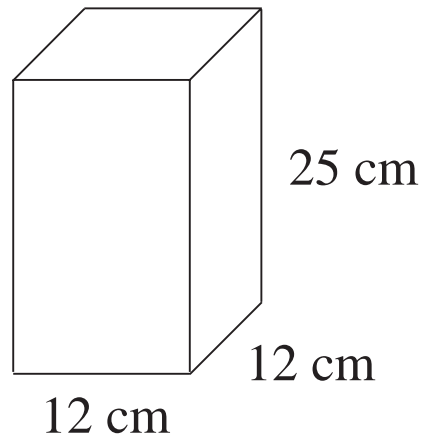

$$A = \text{-----}$$
$$\text{-----}$$
$$\text{-----}$$

c)

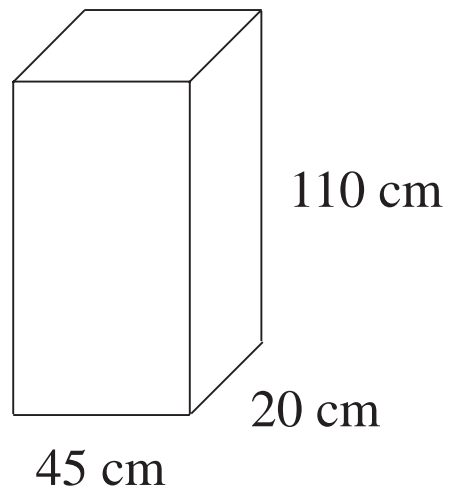

$$A = \text{-----}$$
$$\text{-----}$$
$$\text{-----}$$

a)

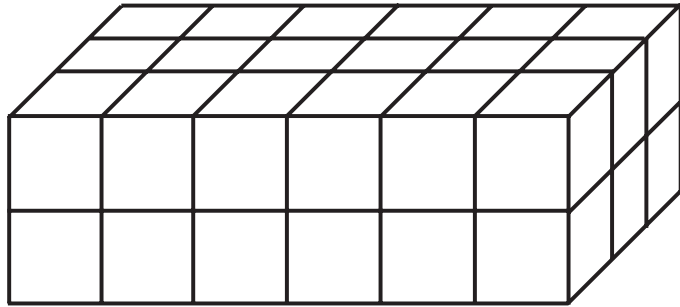

$$A = \dots\dots\dots$$

$$V = \dots\dots\dots$$

b)

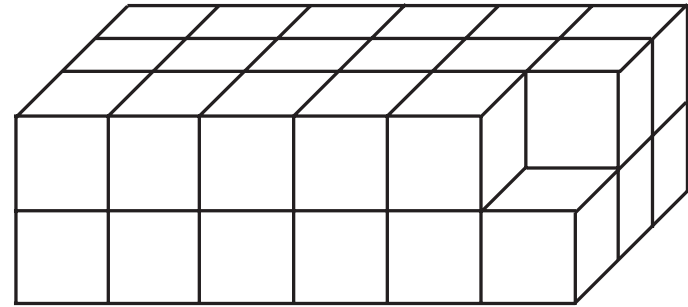

$$A = \dots\dots\dots$$

$$V = \dots\dots\dots$$

c)

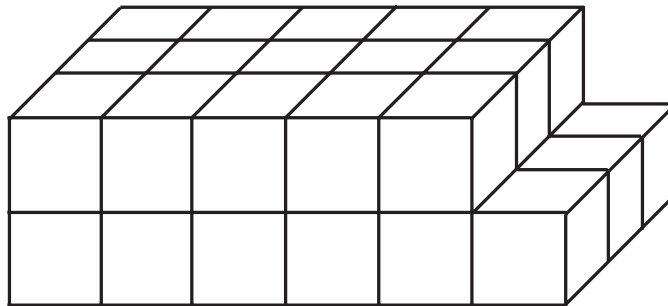

$$A = \dots\dots\dots$$

$$V = \dots\dots\dots$$

a)

i)

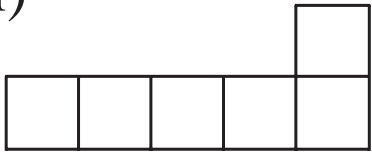

ii)

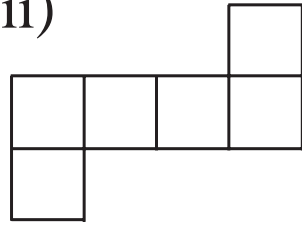

iii)

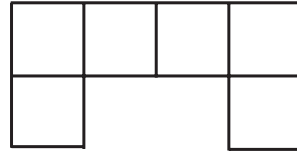

iv)

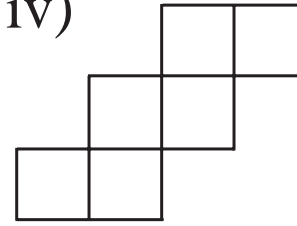

v)

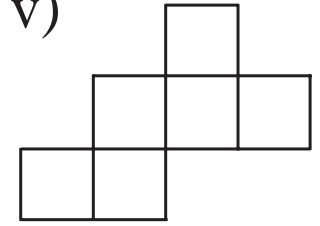

b)

i)

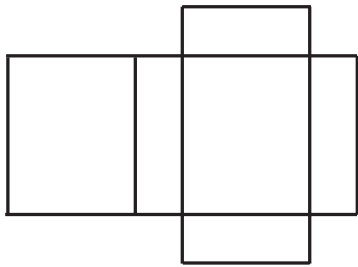

ii)

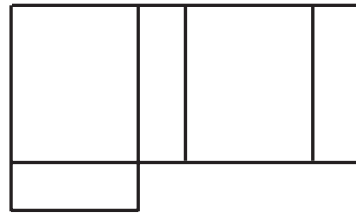

iii)

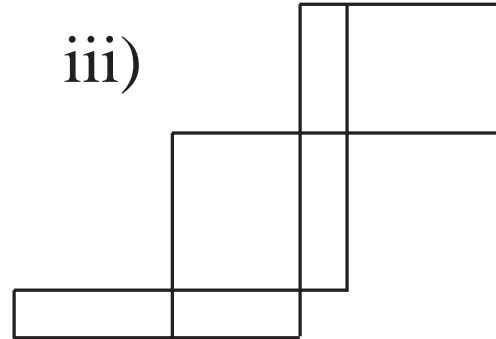

iv)

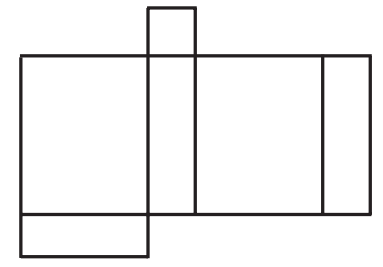

c)

i)

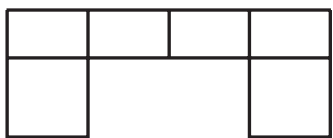

ii)

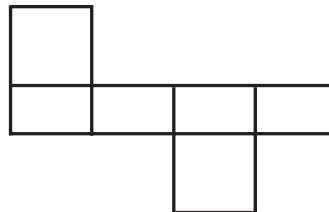

iii)

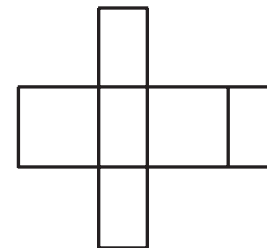

iv)

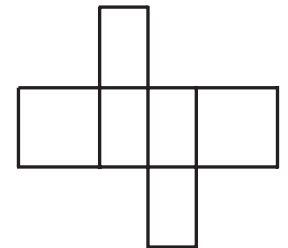

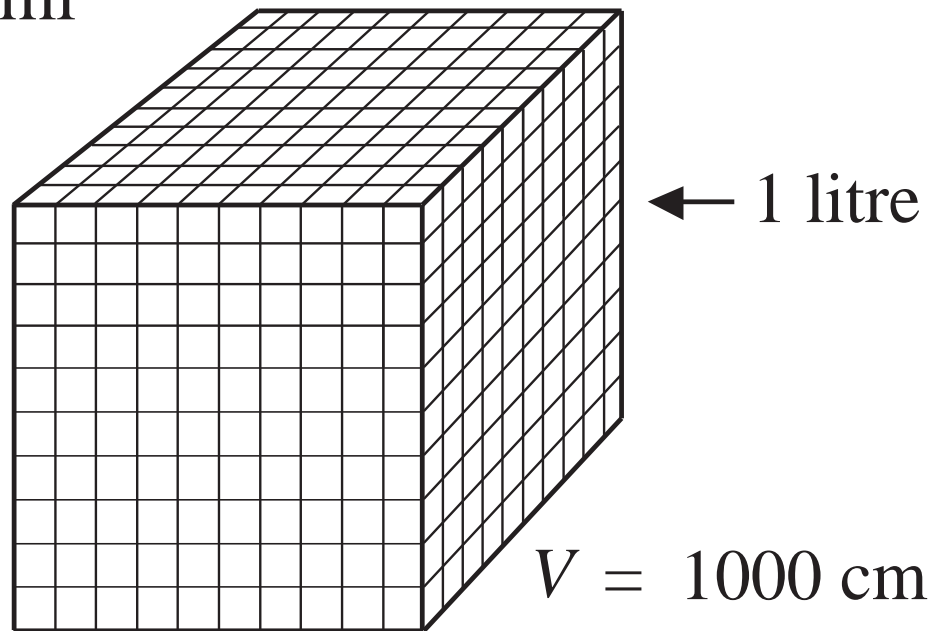
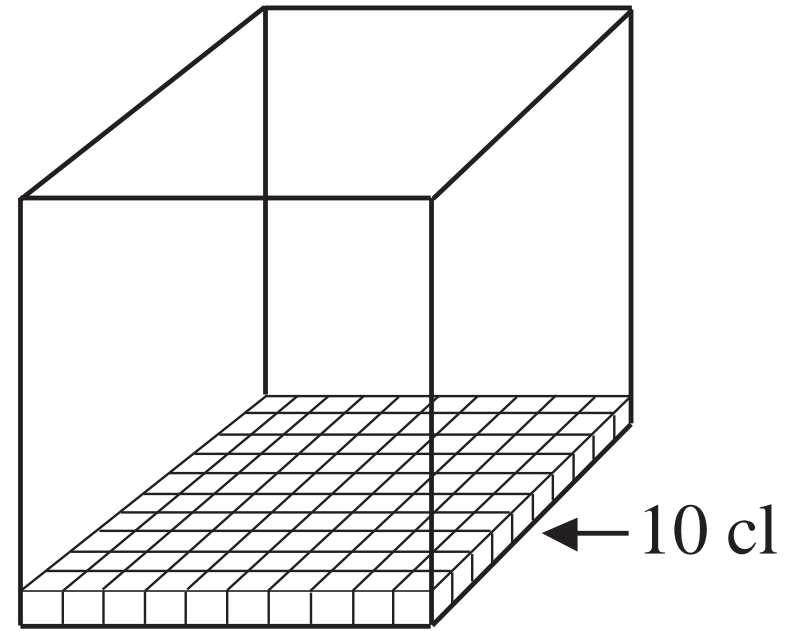
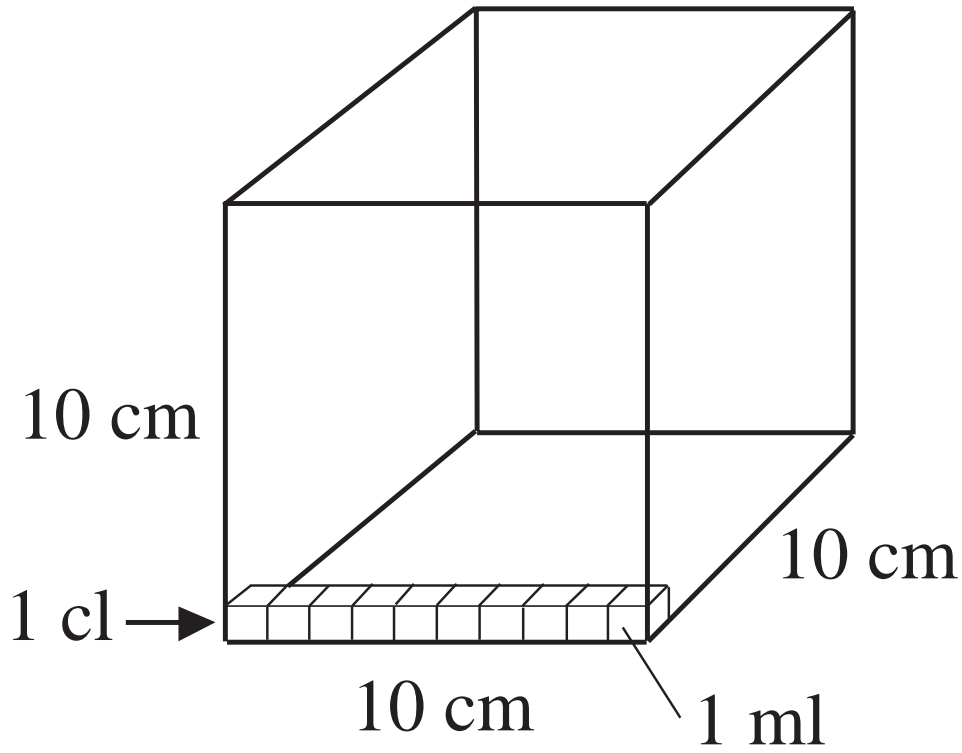

a)

<i>a</i>	<i>b</i>	<i>c</i>

b)

<i>a</i>	<i>b</i>	<i>c</i>

c)

<i>a</i>	<i>b</i>	<i>c</i>

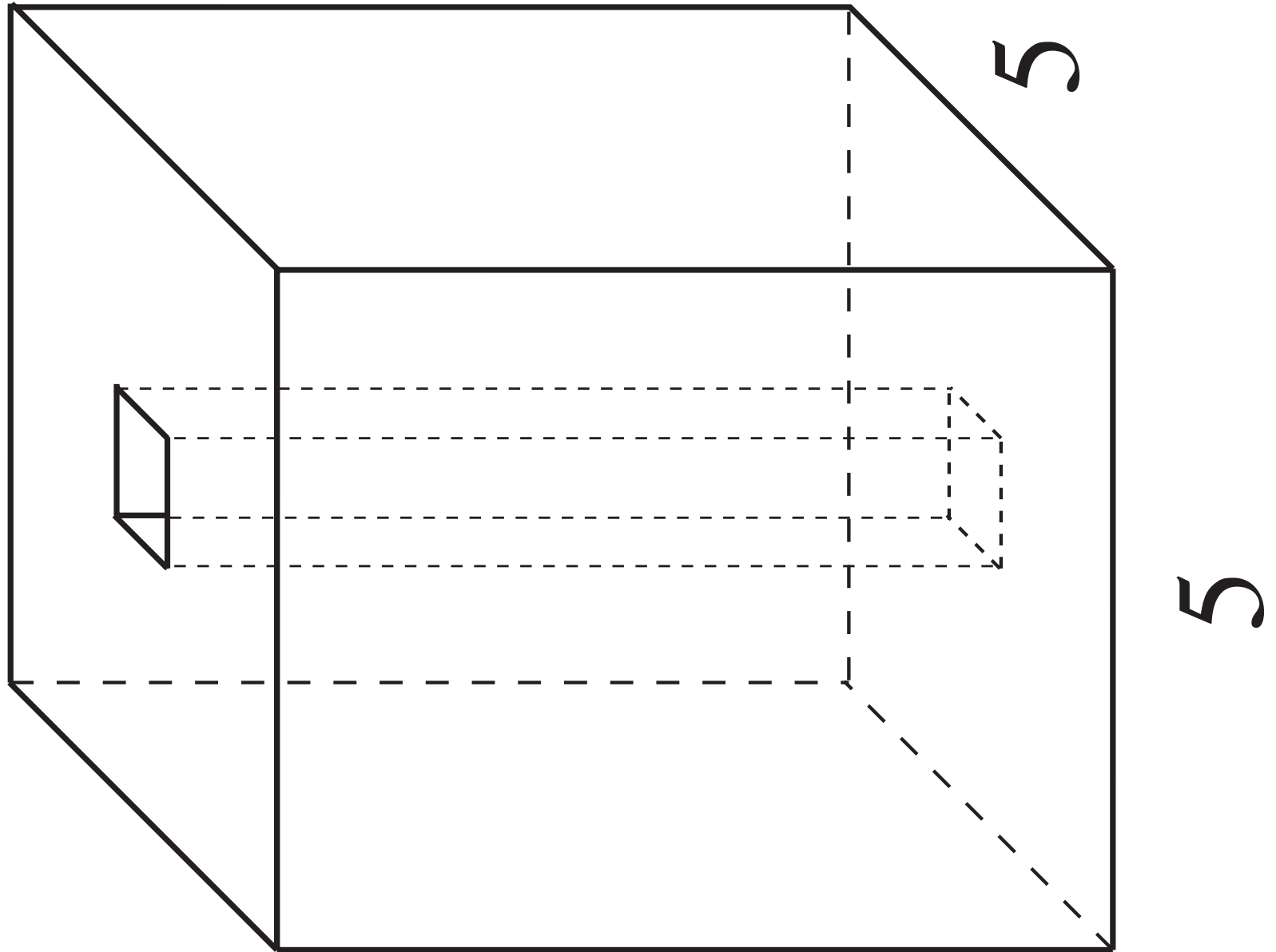

8

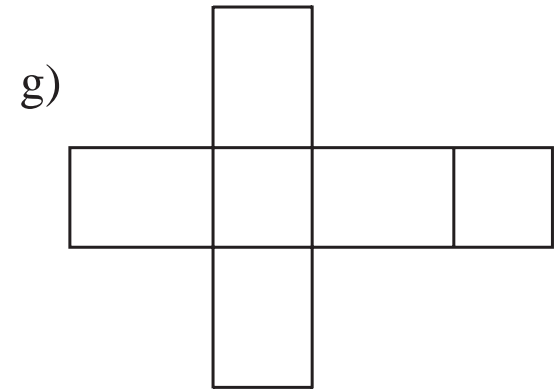
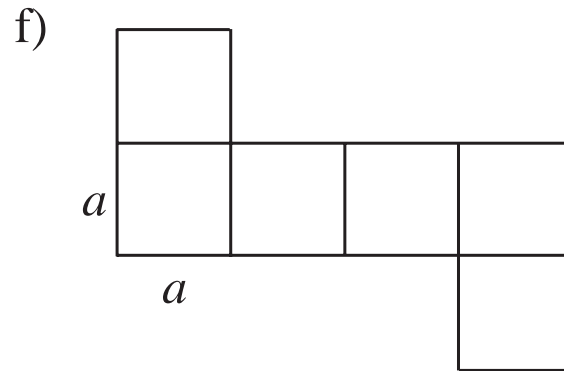
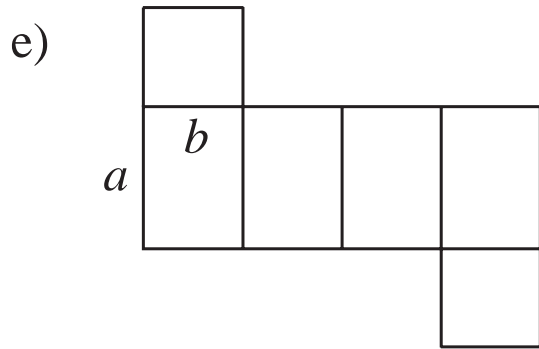
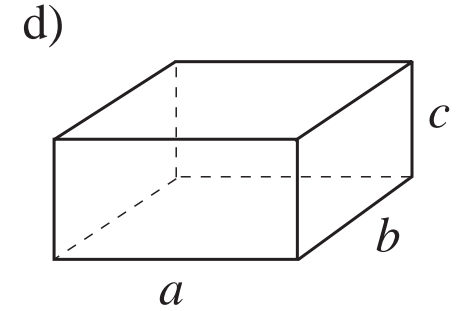
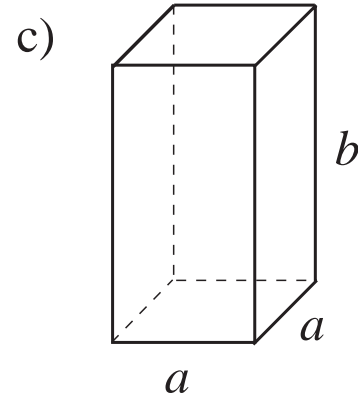
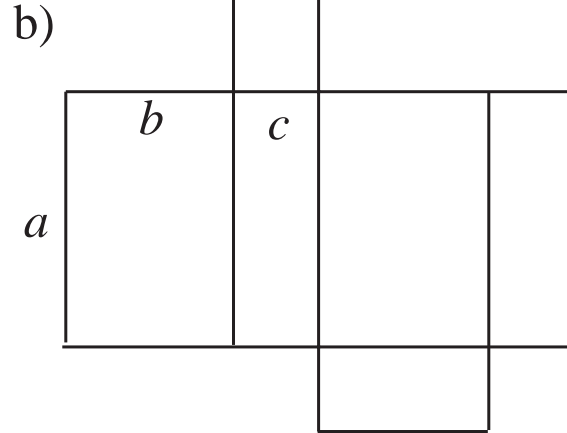
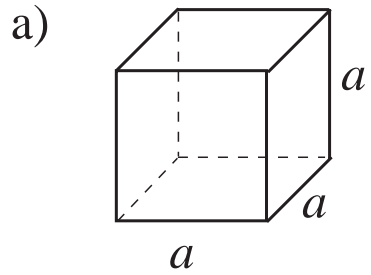

$V =$

cube

$A =$

$V =$

square-based cuboid

$A =$

$V =$

cuboid

$A =$

<i>a</i>								
<i>b</i>								
<i>c</i>								

$$2 \times 2 \times 2 + 4 \times 2 \times 5$$

$$4 \times 15$$

$$(5 + 3) \times 2$$

$$11 \times 5 \times 3$$

$$(4 + 7) \times 2$$

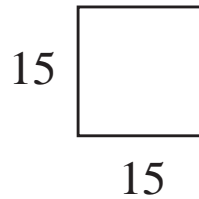
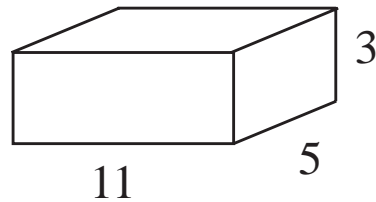
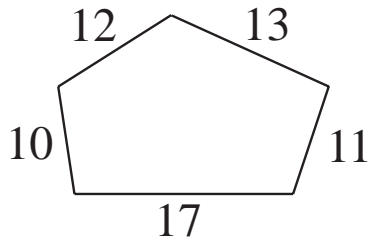
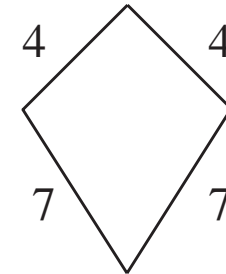
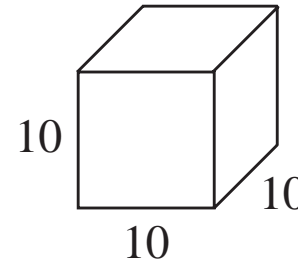
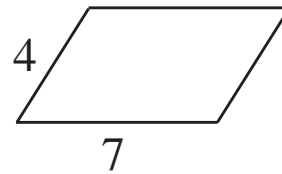
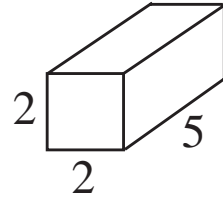
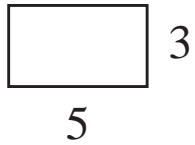

$$10 + 12 + 13 + 11 + 17$$

$$2 \times 2 \times 5$$

$$6 \times 10 \times 10$$

$$(11 \times 5 + 11 \times 3 + 5 \times 3) \times 2$$

$$15 \times 15$$

$$10 \times 10 \times 10$$

$$5 \times 3$$

