

a)	$1 =$					
b)		$1 =$				
c)			$1 =$			
d)				1		
e)					$1 =$	
f)						$1 =$

a) $\frac{1}{2}$ $\frac{1}{3}$ $\frac{1}{4}$ $\frac{1}{6}$ $\frac{1}{9}$ $\frac{1}{12}$

b) $\frac{2}{2}$ $\frac{2}{3}$ $\frac{3}{4}$ $\frac{5}{6}$ $\frac{5}{9}$ $\frac{7}{12}$

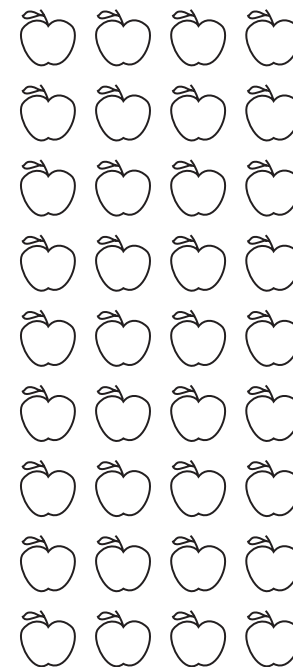

LP 81/4

a) $\frac{1}{5} + \square = 1$ $\square + \frac{3}{5} = 1$ $\frac{6}{5} - \square = 1$ $\square - \frac{4}{5} = 1$

b) $\frac{3}{8} + \square = 1$ $\square + \frac{8}{8} = 1$ $\frac{10}{8} - \square = 1$ $\square - \frac{8}{8} = 1$

c) $\frac{7}{10} + \square = 1$ $\square + \frac{5}{10} = 1$ $\frac{20}{10} - \square = 1$ $\square - \frac{5}{10} = 1$



i) $\frac{\square}{3} + \frac{\square}{\square} = \frac{\square}{\square} = 1$

ii) $1 - \frac{\square}{\square} = \frac{2}{\square}$

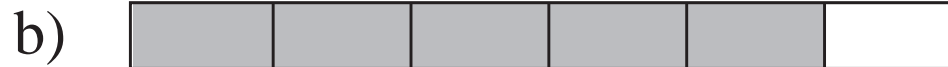

i) $\frac{\square}{6} + \frac{\square}{\square} = \frac{\square}{\square} = 1$

ii) $1 - \frac{\square}{\square} = \frac{\square}{\square}$



i) $\frac{4}{\square} + \frac{\square}{\square} = \frac{\square}{\square} = 1$

ii) $1 - \frac{\square}{\square} = \frac{\square}{\square}$

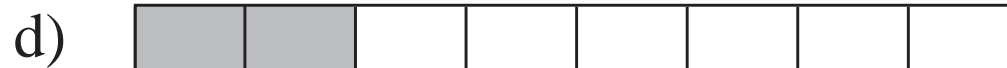

i) $\frac{1}{\square} + \frac{\square}{\square} = \frac{\square}{\square} = 1$

ii) $1 - \frac{\square}{\square} = \frac{\square}{\square}$

a)

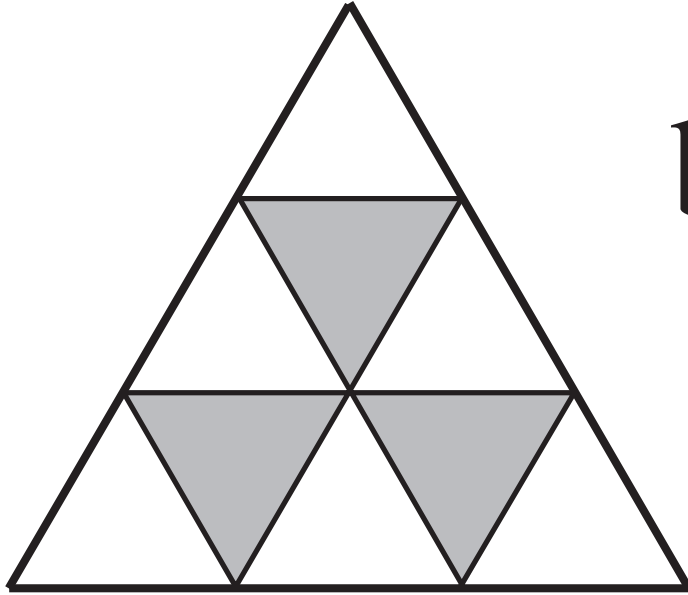

b)

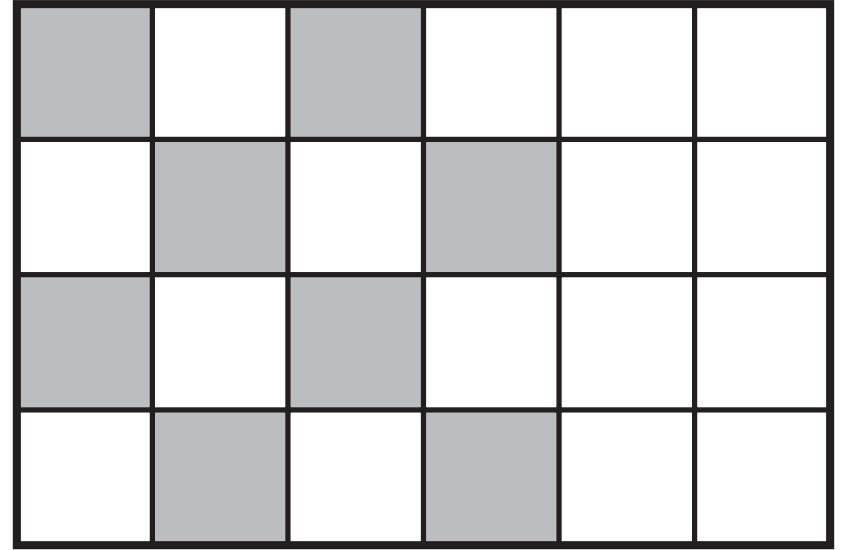

c)

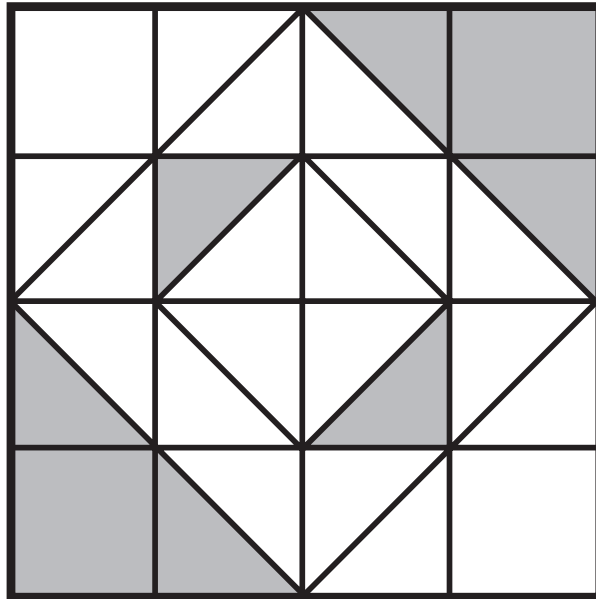

a)

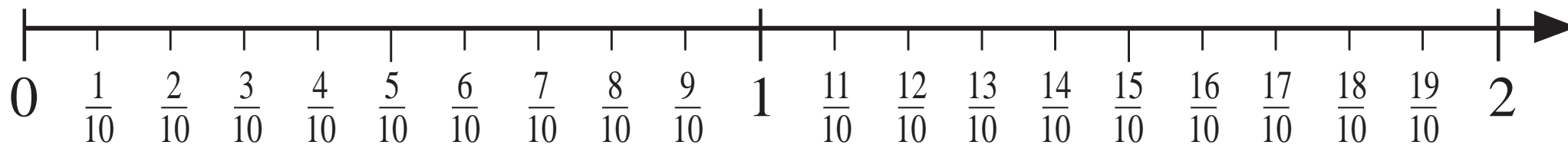

b)

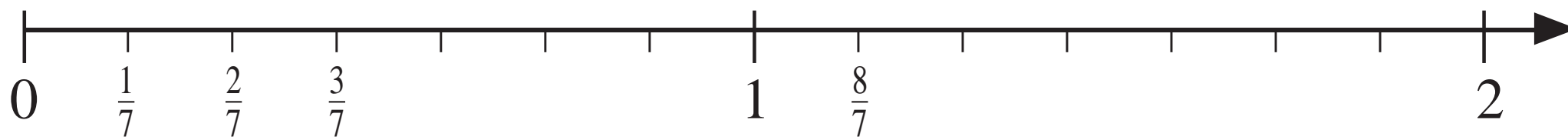

a)

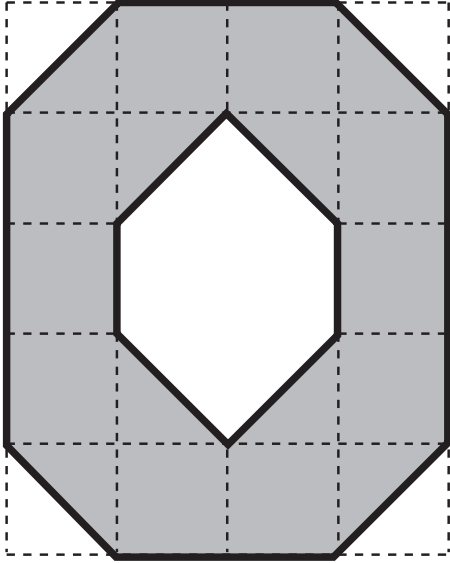

b)

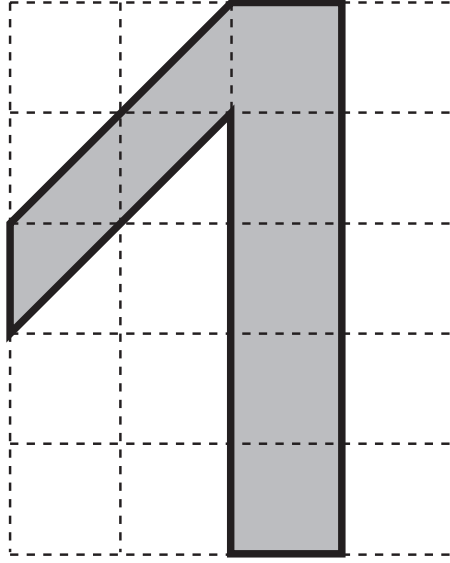

c)

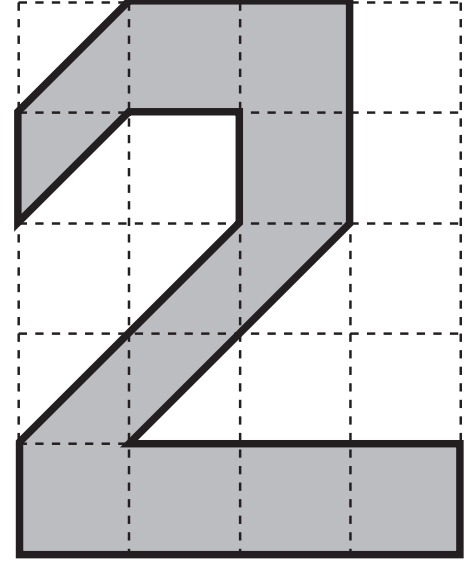

d)

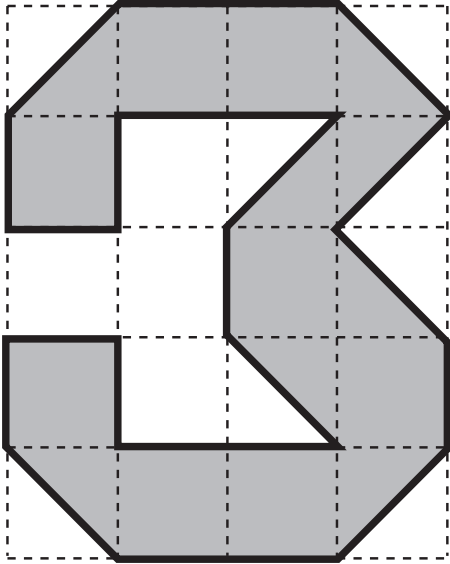

e)

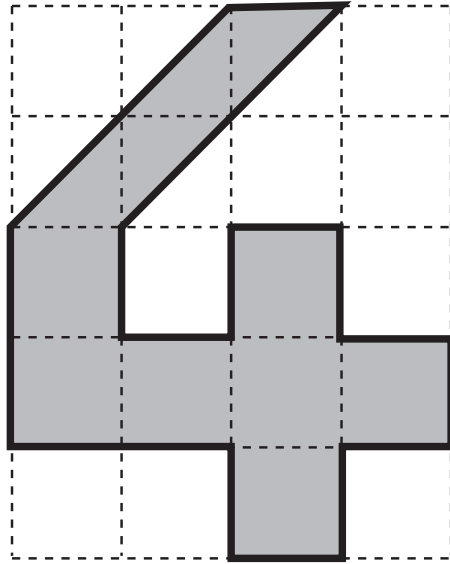

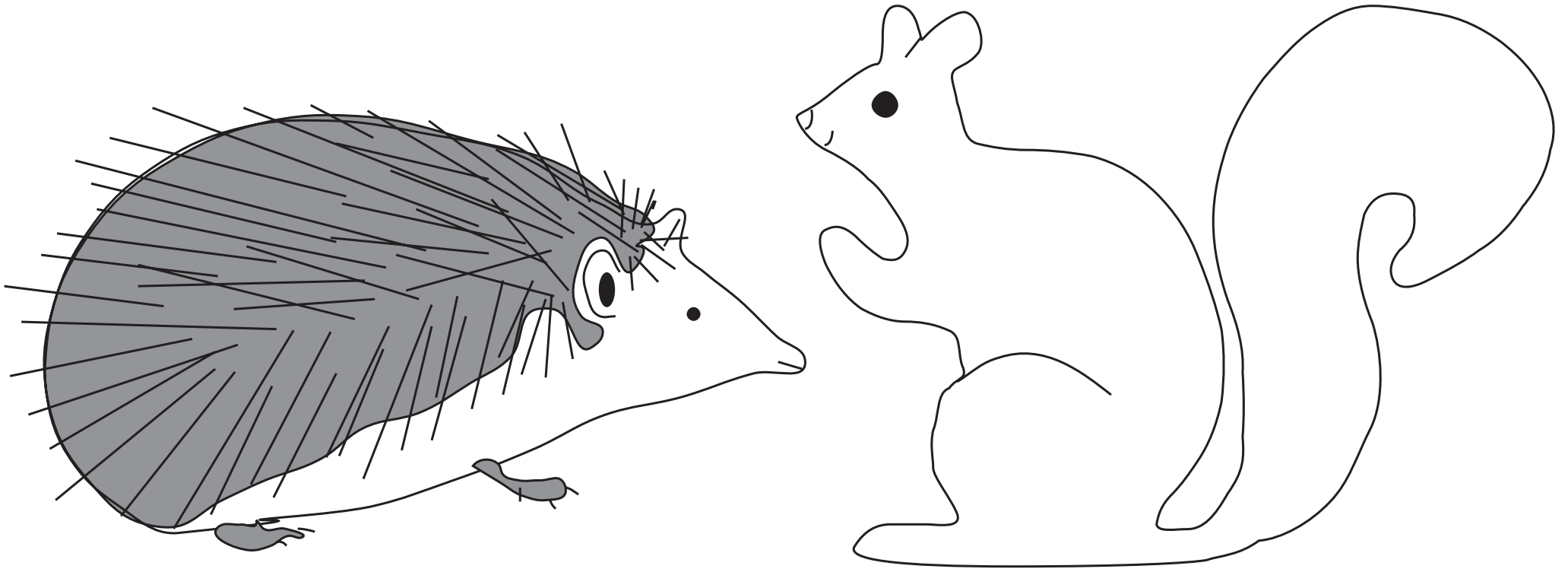

400 m



a) $\frac{1}{2}$

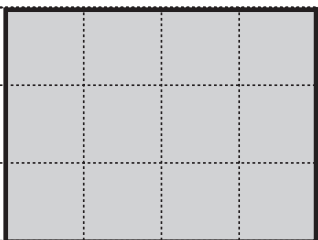

b) $\frac{3}{4}$

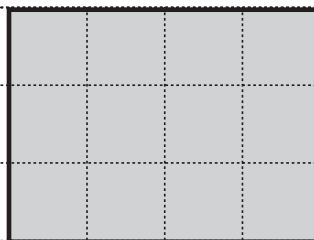

c) $\frac{4}{5}$

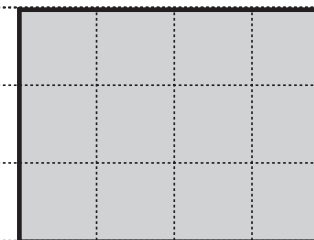

d) $\frac{6}{5}$

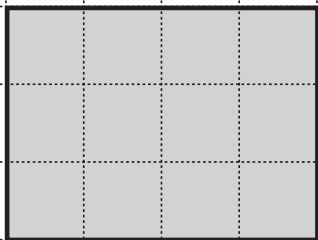

e) $3\frac{1}{1}$

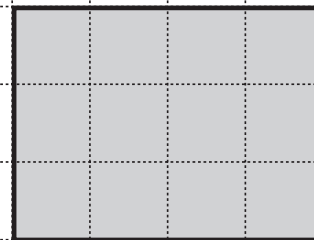

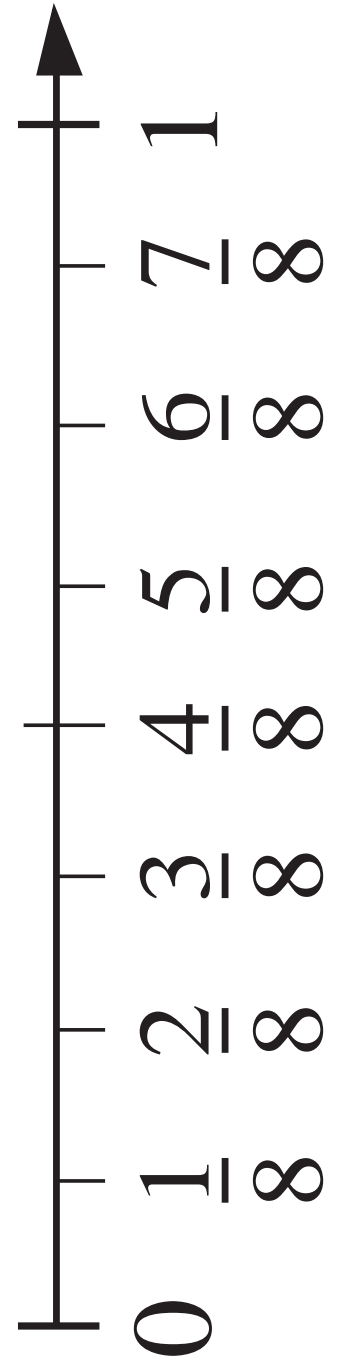
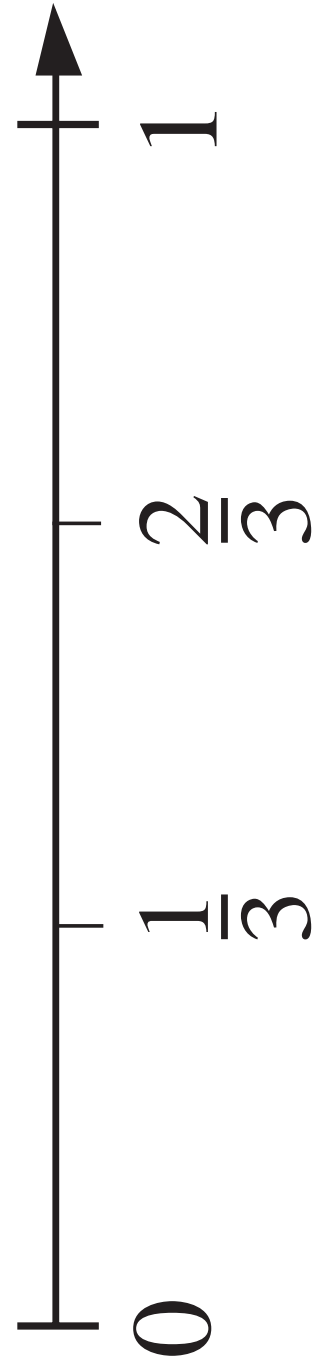
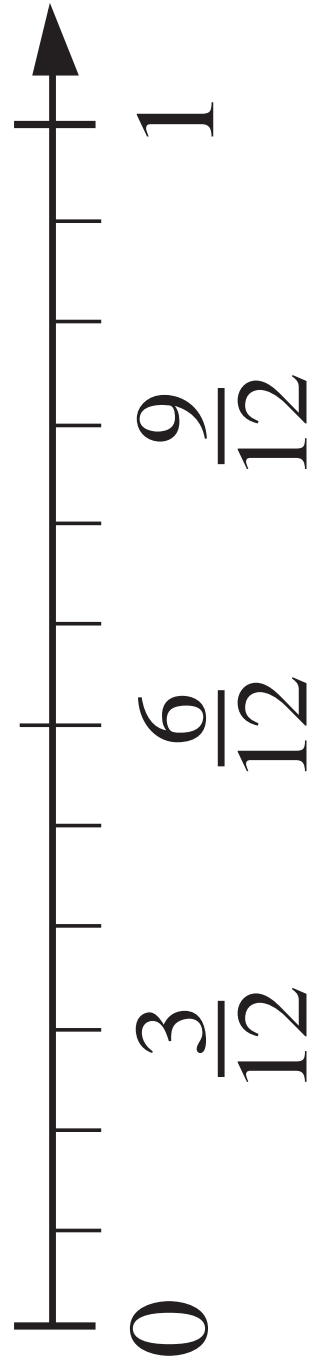
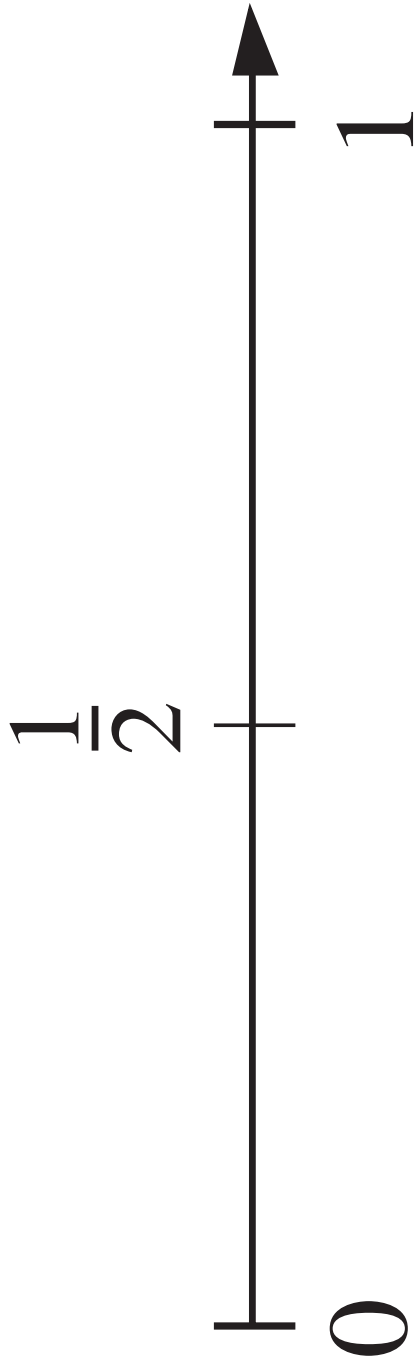

	$\frac{2}{5}$	$\frac{1}{2}$		$\frac{4}{3}$	$\frac{5}{2}$	$\frac{10}{20}$	
2	$\frac{3}{6}$	$\frac{4}{10}$	$\frac{5}{10}$	$1\frac{1}{3}$	$\frac{6}{3}$		$\frac{4}{2}$

LP 83/4

a)

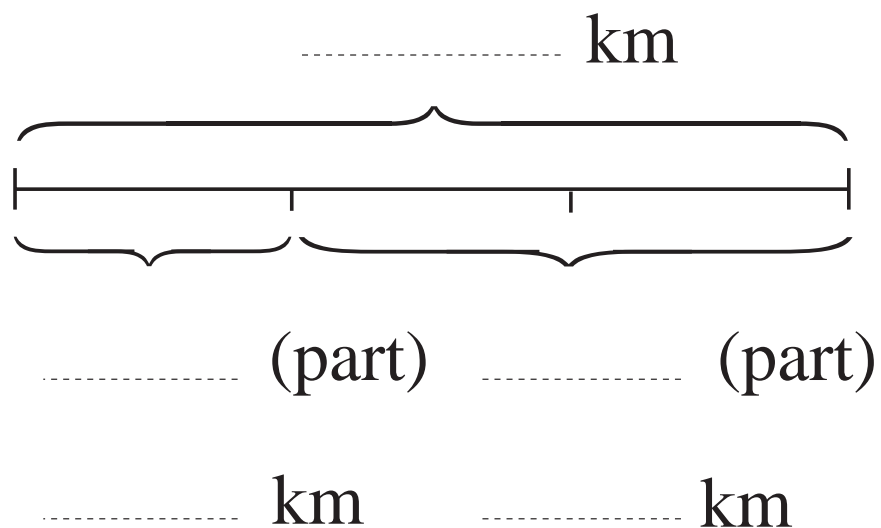

b)

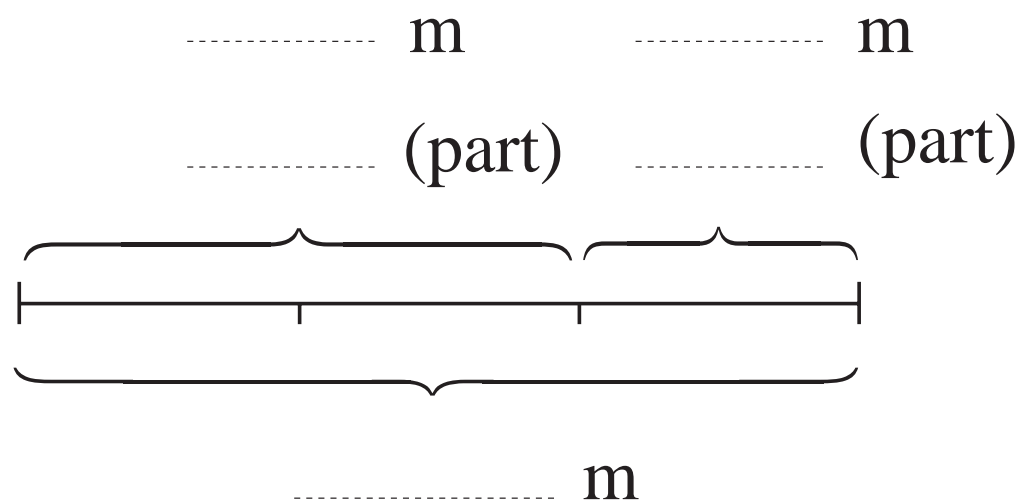

LP 83/6

a)

$$\frac{1}{2}$$

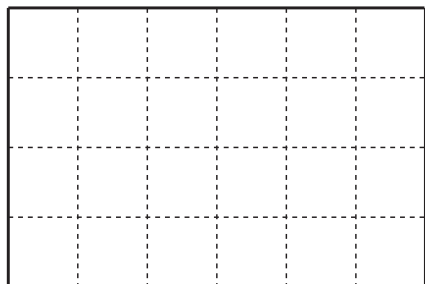

$$\frac{2}{4}$$

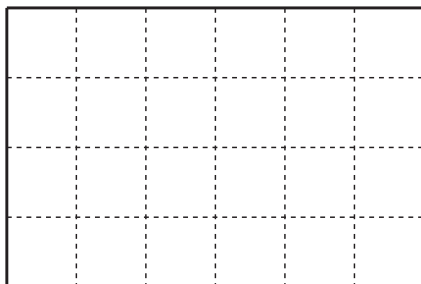

$$\frac{3}{4}$$

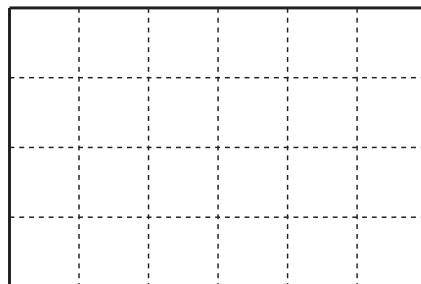

$$\frac{4}{8}$$

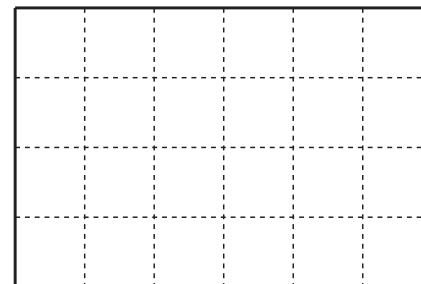

b)

$$\frac{2}{3}$$

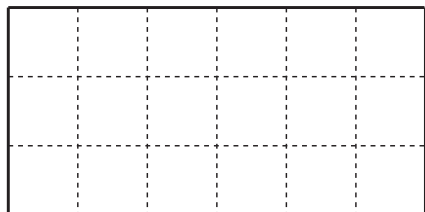

$$\frac{4}{6}$$

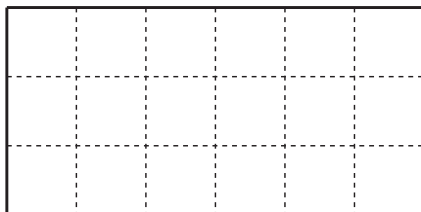

$$\frac{6}{9}$$

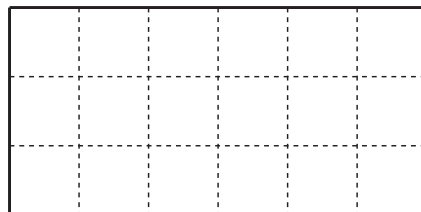

$$\frac{12}{18}$$

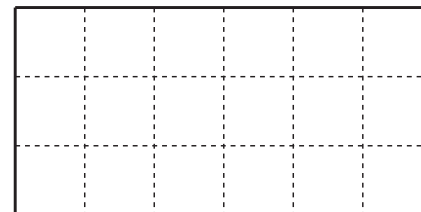

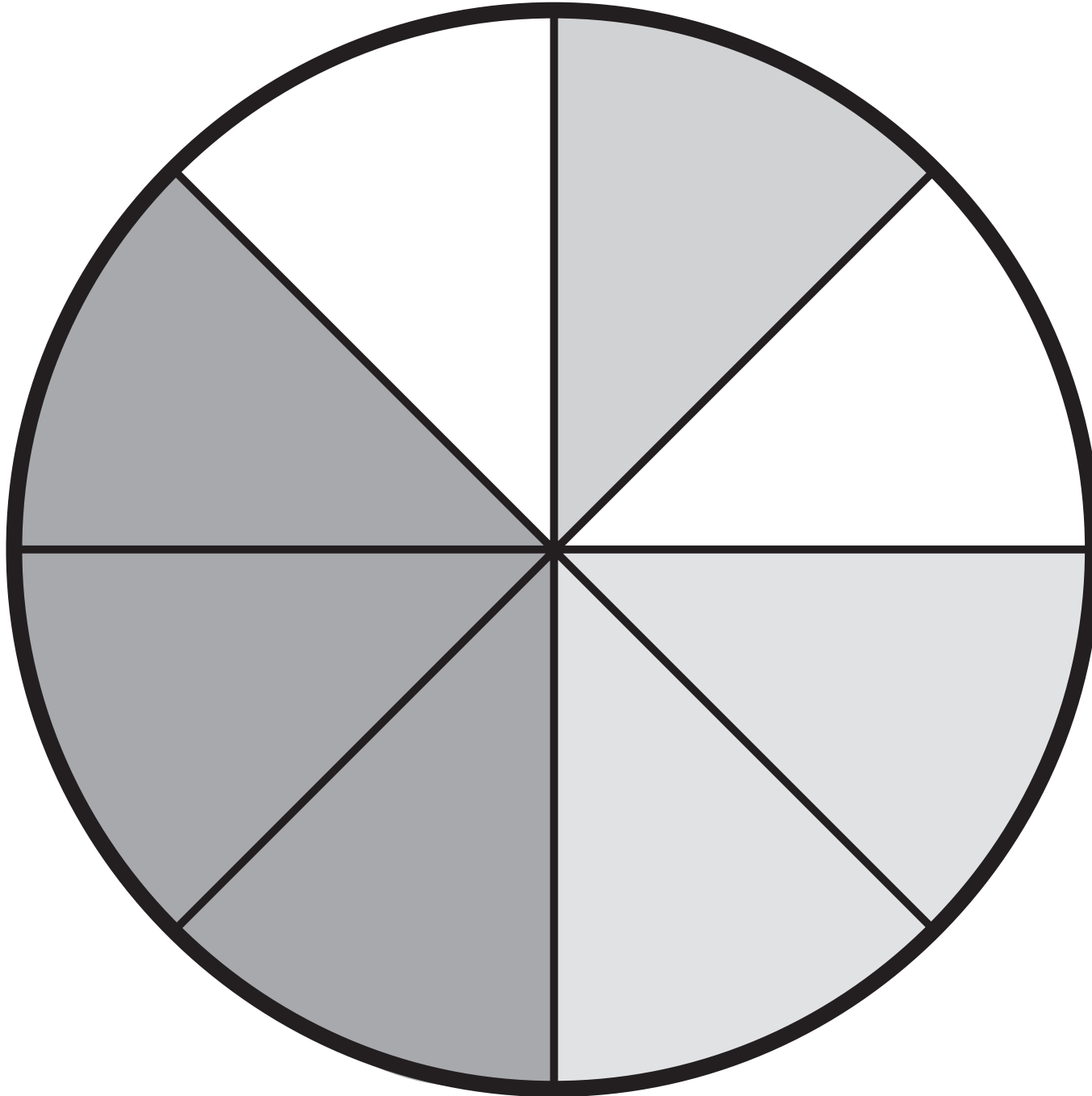

(Or stick different colours of paper on the shaded segments)

a)

i) $\frac{3}{5}$

 1

ii) $\frac{5}{3}$

 1

iii) $\frac{11}{10}$

 1

iv) $\frac{10}{11}$

 1

b)

i) $\frac{5}{8}$

 $\frac{1}{2}$

ii) $\frac{4}{10}$

 $\frac{1}{2}$

iii) $\frac{7}{14}$

 $\frac{1}{2}$

iv) $\frac{5}{11}$

 $\frac{1}{2}$

a) $\frac{1}{2} + \frac{3}{4} + \frac{1}{2} =$

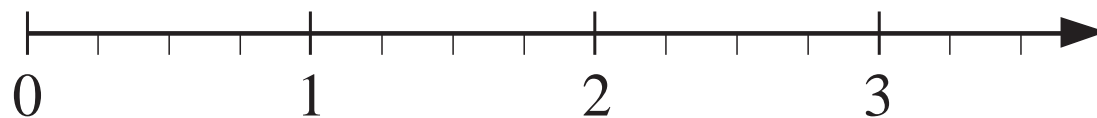

b) $\frac{4}{5} - \frac{1}{5} =$

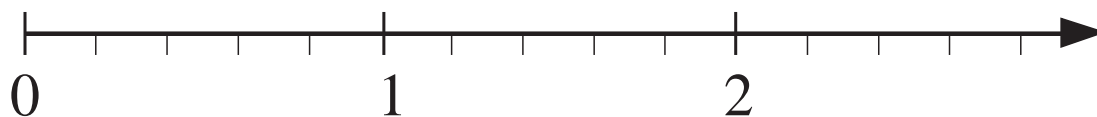

c) $\frac{5}{6} + \frac{2}{6} - \frac{4}{6} =$



<i>a</i>	$\frac{3}{10}$	$\frac{1}{10}$	$\frac{8}{10}$	$\frac{5}{10}$			$2\frac{1}{10}$	$\frac{1}{5}$		
<i>b</i>	$\frac{7}{10}$	$\frac{5}{10}$	$\frac{12}{10}$		$\frac{4}{10}$	1			$\frac{31}{10}$	$\frac{4}{5}$

LP 84/8

a) $\frac{1}{6} + \square = 1$ $\square + \frac{3}{4} = 1$ $\frac{4}{3} - \square = 1$ $1 - \frac{2}{5} = \square$

b) $\frac{3}{7} + \square = 1$ $\square + \frac{5}{8} = 1$ $\frac{7}{6} - \square = 1$ $1 - \frac{4}{9} = \square$

LP 85/3

a)	$1 = \begin{array}{ c } \hline \square \\ \hline \square \\ \hline \end{array}$				
b)		$1 = \begin{array}{ c } \hline \square \\ \hline \square \\ \hline \end{array}$			
c)			$1 = \begin{array}{ c } \hline \square \\ \hline \square \\ \hline \end{array}$		
d)				$1 = \begin{array}{ c } \hline \square \\ \hline \square \\ \hline \end{array}$	
e)					$1 = \begin{array}{ c } \hline \square \\ \hline \square \\ \hline \end{array}$

Rule:

a) 740, 900, 1060, 1220, _____, _____, _____,

b) 6561, 2187, 729, 243, _____, _____, _____,

c) 8900, 7900, 7000, 6200, _____, _____, _____,

Rule:

d) $\frac{2}{9}$, $\frac{3}{9}$, $\frac{4}{9}$, $\frac{5}{9}$, _____, _____, _____,

Rule:

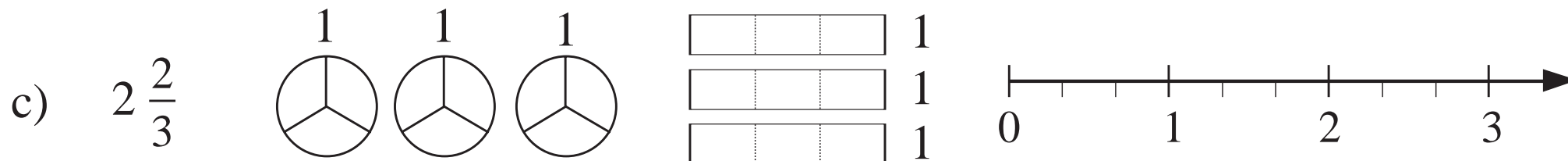
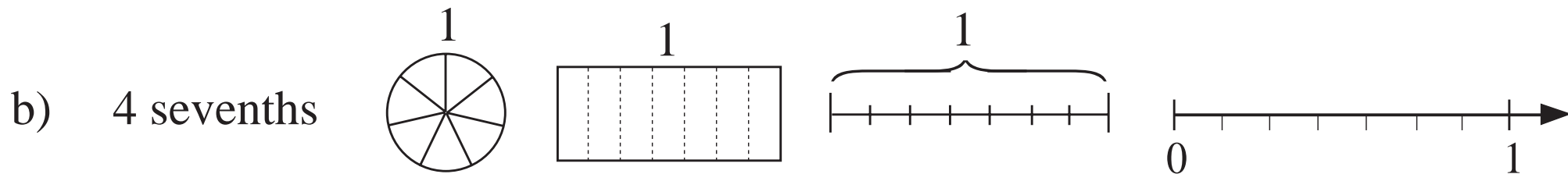
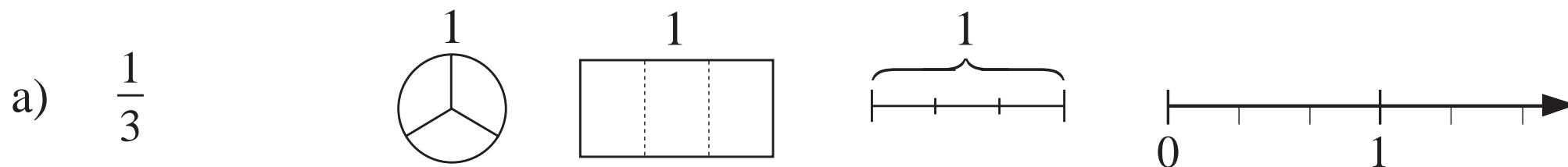

a) $3740 < \square < 3752$

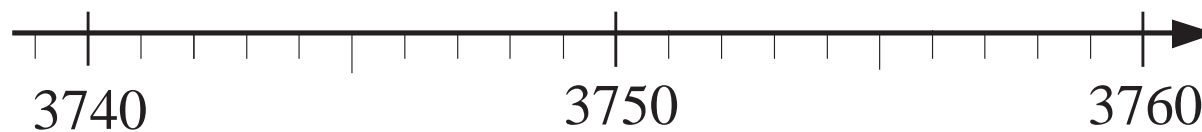

\square :

.....

b) $\frac{3}{14} \leq \square < \frac{9}{14}$

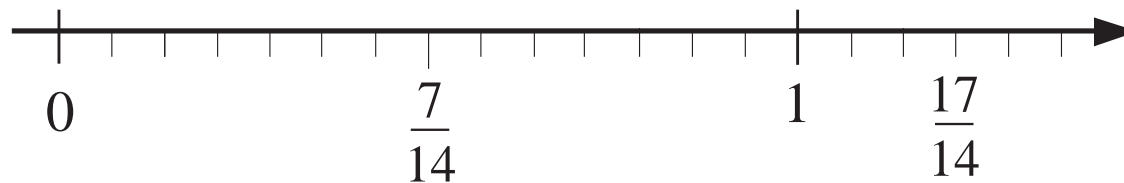

\square :

.....

$$\text{a) } 438 + \boxed{} = 1000$$

$$\text{b) } \boxed{} - 4500 = 2900$$

$$\text{c) } 8200 - \boxed{} = 2800$$

$$\text{d) } \frac{3}{8} + \boxed{} = \frac{7}{8}$$

$$\text{e) } \boxed{} - \frac{2}{15} = \frac{11}{15}$$

$$\text{f) } 1 - \boxed{} = \frac{4}{7}$$

a)

A	3	6	9	12	15	18	21	24	27	30	33					450		$\frac{3}{4}$		
B	2	4										24	26	28	30		70		$\frac{2}{5}$	5

b)

X	1	2	$\frac{3}{5}$	$\frac{4}{5}$		$1\frac{2}{5}$	$\frac{13}{5}$			20				
Y	$\frac{2}{5}$	$1\frac{2}{5}$	0	$\frac{1}{5}$	$\frac{3}{5}$			$\frac{6}{5}$	$5\frac{2}{5}$		40			

Rule:

Capacity	100 litres	800 litres	1 litre	8 litres	10 cl	80 cl
1 half	<i>l</i>	<i>l</i>	cl	cl	ml	ml
1 quarter	<i>l</i>	<i>l</i>	cl	cl	ml	ml
1 tenth	<i>l</i>	<i>l</i>	cl	cl	ml	ml
1 fifth	<i>l</i>	<i>l</i>	cl	cl	ml	ml
2 fifths	<i>l</i>	<i>l</i>	cl	cl	ml	ml
3 tenths	<i>l</i>	<i>l</i>	cl	cl	ml	ml

Mass	1 kg	12 kg	24 kg	200 g	400 g	6 tonnes
$\frac{1}{2}$	g	g	g	g	g	kg
$\frac{1}{4}$	g	g	g	g	g	kg
$\frac{1}{10}$	g	g	g	g	g	kg
$\frac{1}{5}$	g	g	g	g	g	kg
$\frac{2}{5}$	g	g	g	g	g	kg

a)

Capacity	1 litre	7 litres		$\frac{1}{2}$ litre	l	100 l		$\frac{3}{4}$ litre
Mass	1 kg		4 kg	g	250 g		50 kg	g

b)

Capacity	1 ml	8 ml		1 cl		200 ml		$1\frac{1}{2}$ ml
Mass	1 g		13 g		10 g		50 g	

a) $5600 \xrightarrow{+400} \square \xrightarrow{+500} \square \xrightarrow{+300} \square \xrightarrow{+200} \square$

b) $5600 \xrightarrow{+500} \square \xrightarrow{+200} \square \xrightarrow{+400} \square \xrightarrow{+300} \square$

c) $5600 \xrightarrow{+400} \square \xrightarrow{-500} \square \xrightarrow{+300} \square \xrightarrow{-200} \square$

d) $5600 \xrightarrow{-400} \square \xrightarrow{-500} \square \xrightarrow{-300} \square \xrightarrow{-200} \square$

e) $5600 \xrightarrow{-300} \square \xrightarrow{-200} \square \xrightarrow{-400} \square \xrightarrow{-500} \square$

a)

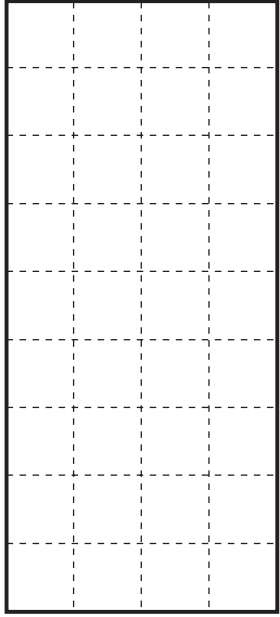

small
squares

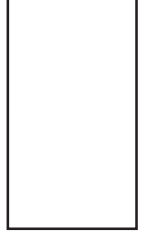

b)

 i) $\frac{1}{2}$

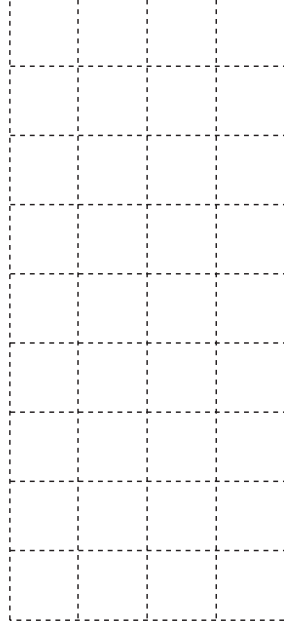
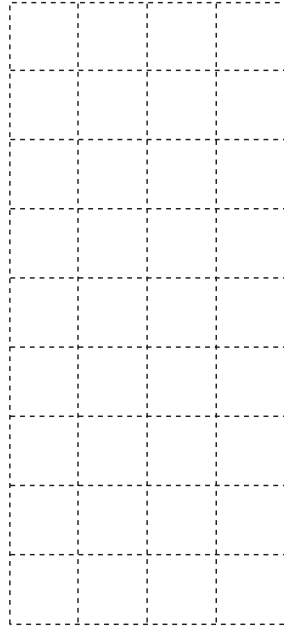
 ii) $\frac{2}{3}$

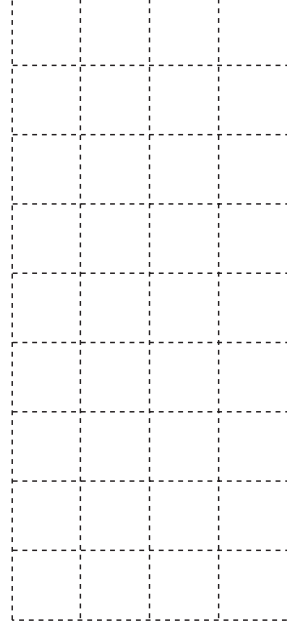
 iii) $\frac{3}{4}$

 iv) $\frac{5}{9}$

Part of total	$\frac{1}{2}$	$\frac{1}{3}$	$\frac{1}{6}$	$\frac{3}{2}$	$\frac{3}{3}$	$\frac{3}{6}$	$\frac{2}{3}$	$\frac{4}{6}$	$\frac{6}{3}$
Number of 									

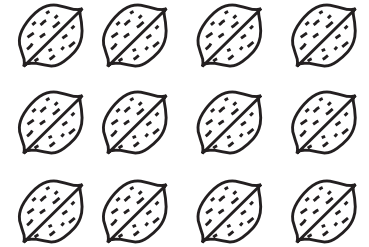
The whole:



Part of total	$\frac{1}{2}$	$\frac{1}{3}$	$\frac{1}{6}$	$\frac{3}{2}$	$\frac{3}{3}$	$\frac{3}{6}$	$\frac{2}{3}$	$\frac{4}{6}$	$\frac{6}{3}$
Total no. of 									

The part:

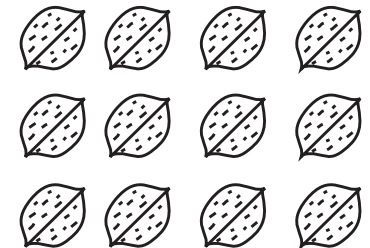

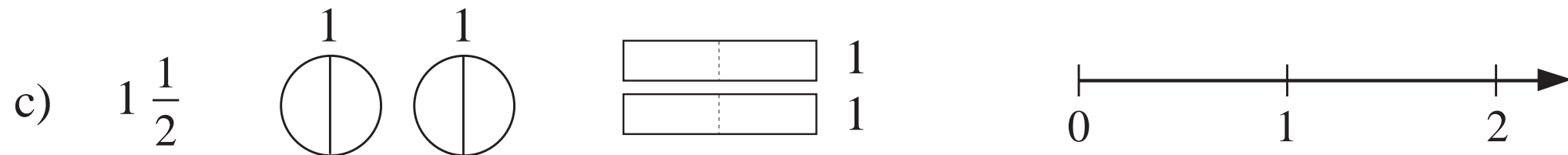
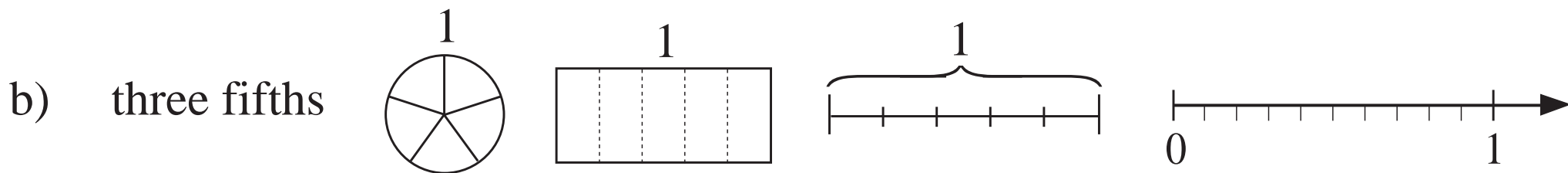

<i>A</i>	0	5	10	15	20	25	30					100		2
<i>B</i>	0	2						14	16	18	20		100	

Rule: $A =$

LP 90/3

a) $1525 < \star < 1530$ $\star : \dots\dots\dots$

b) $\frac{6}{11} \leq \star < 1$ $\star : \dots\dots\dots$

c) $1\frac{1}{8} \leq \star < 1\frac{1}{2}$ $\star : \dots\dots\dots$

LP 90/4

a) $8076 =$

b) $3405 =$

c) $10\,007 =$

d) $2220 =$

TTh	Th	H	T	U

a) 65 cm 2 mm

cm	mm

 = mm

4 cm 9 mm

 = mm

503 mm

 = cm mm

b) 2 m 34 cm

m	cm

 = cm

8 m 5 cm

 = cm

412 cm

 = m cm

508 cm

 = m cm

a) i) $1 \text{ mm} = \frac{1}{10}$ ii) $3 \text{ mm} =$ cm

iii) $12 \text{ mm} = 1 \text{ cm } 2 \text{ mm} = \frac{12}{10}$ $= 1 \frac{2}{10}$

b) i) $1 \text{ cm} = \frac{1}{100}$ ii) $5 \text{ cm} =$ m

iii) $62 \text{ cm} = \frac{62}{100}$

c) i) $1 \text{ p} = \text{£}$ ii) $8 \text{ p} = \text{£}$ iii) $36 \text{ p} =$ $\frac{36}{100}$

iv) $145 \text{ p} = \text{£}$ $= \text{£}1 \text{ } 45 \text{ p} =$ $1 \frac{45}{100}$

a) 1 cm is 1 unit

15 cm 3 mm

305 mm

T 10 cm	U 1 cm	t $\frac{1}{10}$ cm

b) 1 m is 1 unit

2 m 85 cm

106 m 4 cm

238 cm

H 100 m	T 10 m	U 1 m	t $\frac{1}{10}$ m	h $\frac{1}{100}$ m

c) £1 is 1 unit

£216 48 p

£30 28 p

£407 6 p

5816 p

H £100	T £10	U £1	t $\frac{1}{10}$ £	h $\frac{1}{100}$ £

	H	T	U	t	h	
	100	10	1	$\frac{1}{10}$	$\frac{1}{100}$	
a) 35 cm 6 mm =						(cm)
1 m 20 cm 4 mm =						
3208 mm =						
b) 1 m 63 cm =						(m)
28 m 40 cm =						
605 cm =						
c) £8 70 p =						(£)
£41 5 p =						
£120 15 p =						
3648 p =						

a) $5 \times 10 + 3 \times 1 + 2 \times \frac{1}{10}$

b) $3 \times 100 + 4 \times 10 + 7 \times 1 + 5 \times \frac{1}{10}$

c) $6 \times 1 + 8 \times \frac{1}{10} + 4 \times \frac{1}{100}$

d) $9 \times \frac{1}{10} + 2 \times \frac{1}{100}$

e) $6 \times 10 + 0 \times 1 + 3 \times \frac{1}{10}$

H 100	T 10	U 1	t $\frac{1}{10}$	h $\frac{1}{100}$

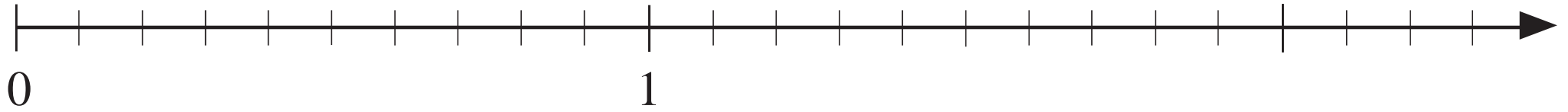

a)

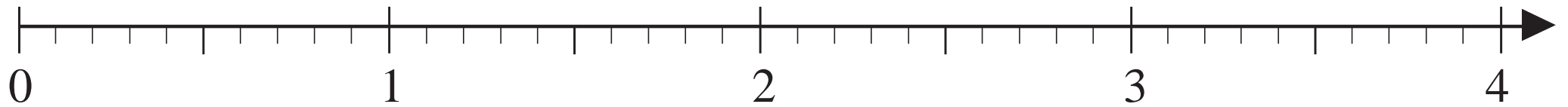

b)



h			8	6	0
t		8	0	3	9
U	8	0	2	4	7
T	0	2		5	
H	2				

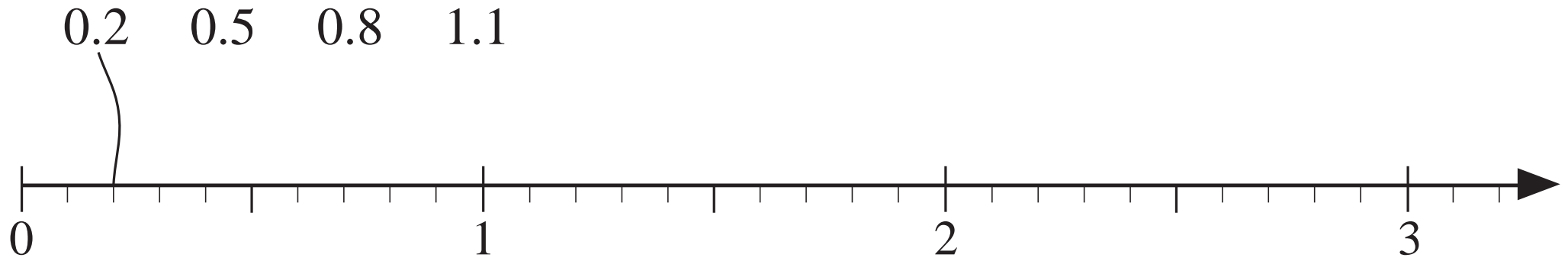

$$1 = \frac{10}{10}$$

$$1 = \frac{2}{2}$$

$$1 = \frac{5}{5}$$

H 100	T 10	U 1	t $\frac{1}{10}$	h $\frac{1}{100}$
	2	5	1	8
1	0	4	3	
		6	5	7

$$2 \times 10 + 5 \times 1 + 1 \times \frac{1}{10} + 8 \times \frac{1}{100} = 25 + \frac{18}{100} = 25.18$$

=

=

$$8 \times 100 + 0 \times 10 + 3 \times 1 + 4 \times \frac{1}{10} =$$

=

$$= 26 + \frac{7}{10} =$$

$$= 26.7 = 26.70$$

a) $15 \text{ m} + \frac{1}{10} \text{ m} + \frac{8}{100} \text{ m} = \boxed{} \text{ m} \boxed{} \text{ cm}$

b) $300.45 \text{ m} = \boxed{} \text{ m} \boxed{} \text{ cm}$

c) $7 \frac{8}{100} \text{ litres} = \boxed{} \text{ litres} \boxed{} \text{ cl}$

d) $\pounds 106.80 = \pounds \boxed{} \boxed{} \text{ p}$

e) $28.5 \text{ kg} = \boxed{} \text{ kg} \boxed{} \text{ g}$

H 100	T 10	U 1	t $\frac{1}{10}$	h $\frac{1}{100}$	
					(m)
					(m)
					(l)
					(£)
					(kg)

a) $\frac{2}{10}$ $\frac{7}{10}$ $\frac{8}{10}$ 0.9 0.6 0.3

b) $\frac{15}{100}$ $\frac{72}{100}$ $\frac{43}{100}$ 0.70 0.52 0.49

c) 0.04 0.1 $\frac{2}{10}$ $\frac{18}{100}$ 0.27 0.3

d) $\frac{1}{5}$ 0.2 $\frac{2}{5}$ 0.3 $\frac{3}{10}$ 0.6

e) $\frac{1}{5}$ $\frac{17}{100}$ $\frac{3}{10}$ 0.51 $\frac{78}{100}$ 0.53

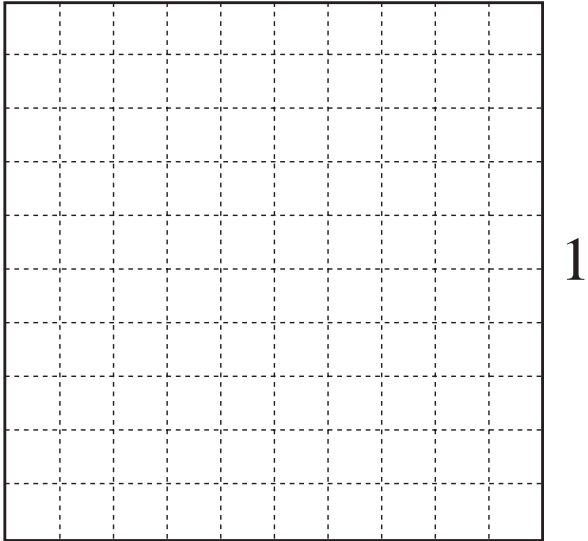
a) $\frac{1}{5}$ of 450 m =

0.28 of 1 km =

b) 0.6 of 150 litres =

$\frac{7}{10}$ of 100 litres =

c) $\frac{1}{4}$ of 28 kg =

0.5 of 14 kg =

d) 0.25 of £220 =

$\frac{3}{4}$ of £90 =

a) $\frac{1}{2} =$ $\frac{2}{2} =$ $\frac{5}{2} =$ $6\frac{1}{2} =$

$$1 = \frac{10}{10}$$

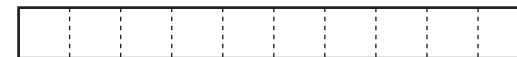

b) $0.1 =$ $0.2 =$ $0.5 =$ $0.9 =$

$$1 = \frac{100}{100}$$

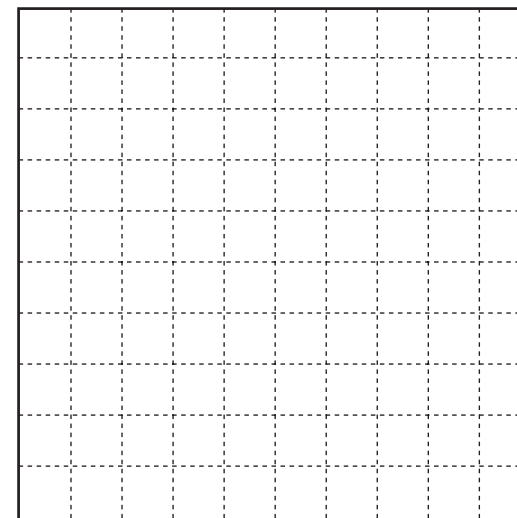

c) $\frac{1}{4} =$ $\frac{3}{4} =$ $2\frac{1}{4} =$ $\frac{19}{4} =$

d) $0.17 =$ $0.30 =$ $2.1 =$ $6.5 =$

e) $1.2 =$ $3.80 =$ $12.05 =$ $0.75 =$

- a) i) $\frac{1}{2}$ litre = ml ii) $\frac{1}{4}$ m = cm mm
- iii) $\frac{1}{5}$ kg = g iv) $\frac{1}{10}$ km = m
- b) i) $\frac{3}{4}$ m = cm = mm ii) $\frac{2}{5}$ litre = ml
- iii) $2\frac{1}{2}$ km = m v) $\frac{3}{10}$ hour = minutes
- c) i) 0.1 km = m ii) 0.2 litre = ml
- iii) 0.3 m = cm = mm iv) 0.7 kg = g
- d) i) 1.3 kg = g ii) 2.5 km = m
- iii) 5.6 m = cm = mm iv) 6.25 litres = ml

- a) $4 \times 100 + 5 \times 1 + 3 \times \frac{1}{10}$
- b) $7 \times 10 + 1 \times 1 + 4 \times \frac{1}{100}$
- c) $1 \times 100 + 3 \times \frac{1}{10} + 9 \times \frac{1}{100}$
- d) $9 \times \frac{1}{10} + 2 \times \frac{1}{100}$
- e) $7 \times 1 + 5 \times \frac{1}{100}$

H 100	T 10	U 1	t $\frac{1}{10}$	h $\frac{1}{100}$

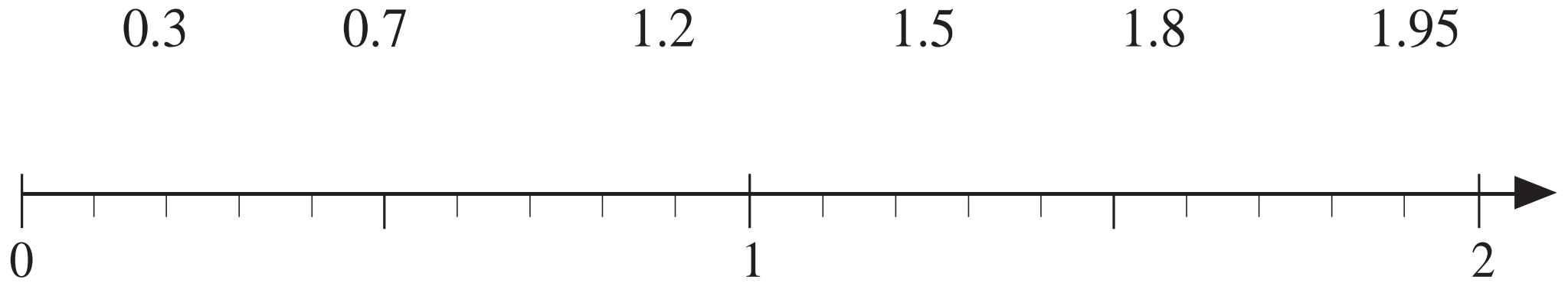

a) $1.1 \text{ m} + 230 \text{ cm} + 8600 \text{ mm}$

In mm

In cm

In m

10 m	1 m	10 cm	1 cm

b) $13.4 \text{ litres} + 1580 \text{ cl} + 2500 \text{ ml}$

In ml

In cl

In litres

10 ℓ	1 ℓ	10 cl	1 cl

a) $4.73 \text{ m} - 210 \text{ cm}$

In mm

In cm

In m

1 m	10 cm	1 cm

b) $18.6 \text{ litres} - 7900 \text{ ml}$

In ml

In cl

In litres

10 l	1 l	10 cl	1 cl

$$\text{a) } \quad 4.9 \quad = \quad 4 + \frac{9}{10} \quad = \quad 4 + \frac{90}{100} \quad = \quad 4.90$$

$$\quad 10.23 \quad = \quad \quad = \quad \quad =$$

$$\quad + 7.04 \quad = \quad \quad = \quad \quad =$$

$$\quad = \quad \quad =$$

$$\text{b) } \quad 6.81 \quad = \quad \quad = \quad \quad =$$

$$\quad - 2.7 \quad = \quad \quad = \quad \quad =$$

$$\quad = \quad \quad = \quad \quad =$$

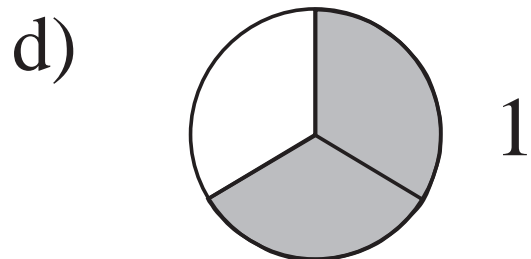
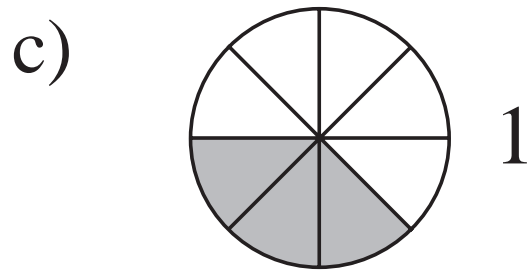
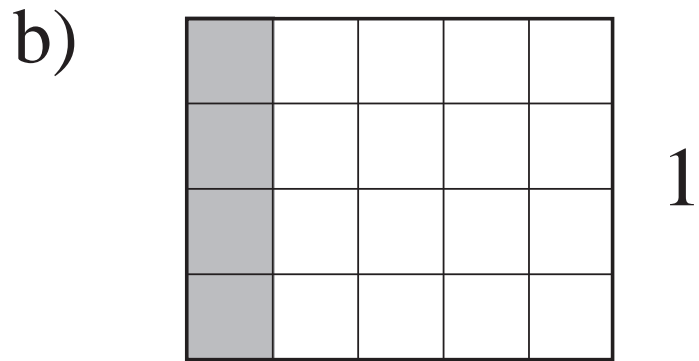

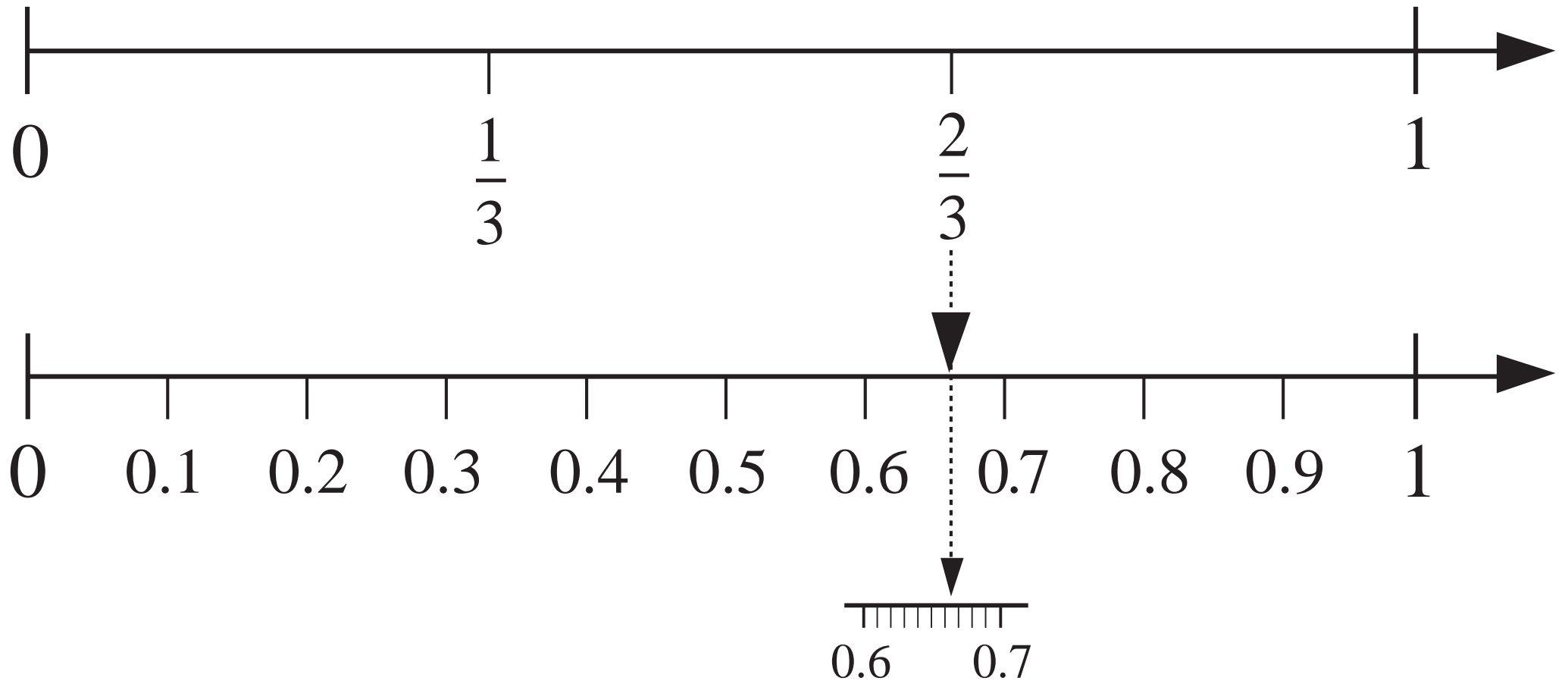

a) $7.3 + 6.81 =$

T	U	t	h

b) $22.8 - 13 =$

T	U	t	h

a) $1.1 + 42.6 + 0.8$
 \approx

T	U	t

b) $62 + 6.2 + 0.62$
 \approx

T	U	t	h

c) $22.5 - 13.7$
 \approx

T	U	t

d) $32.8 - 13$
 \approx

T	U	t

e) $32 - 13.7$
 \approx

T	U	t

a)

		2	.	4
	1	0	.	3
+	8	7	.	2
<hr/>				

b)

	4	2	.	1
		5	.	6
+		0	.	7
<hr/>				

c)

	1	2	.	3	6
		1	.	7	2
+	4	9	.	5	8
<hr/>					

d)

	6	0	0	0	.	8
		4	0	9	.	4
+	1	0	2	6	.	9
<hr/>						

e)

	1	0	.	5	
		4	.	6	5
+	2	3	.	1	7
<hr/>					

f)

	1	3			
		0	.	9	
+		3	.	0	5
<hr/>					

a)

	4	9	.	6
-	1	6	.	2

b)

	8	9	.	5
-	5	2	.	6

c)

	4	2	.	1	5
-		8	.	9	

d)

	8	5	.	4	
-	1	6	.	2	7

e)

	6	5	.	6	4
-	3	9	.	3	

f)

	4	0		
-	3	5	.	6

a) 1 unit

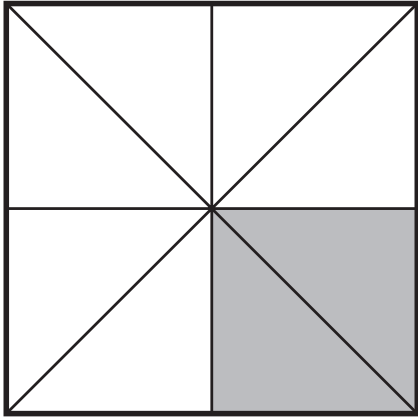

b) 1 unit

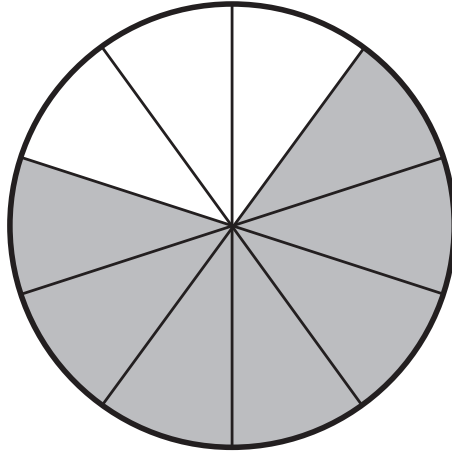

c) 1 unit

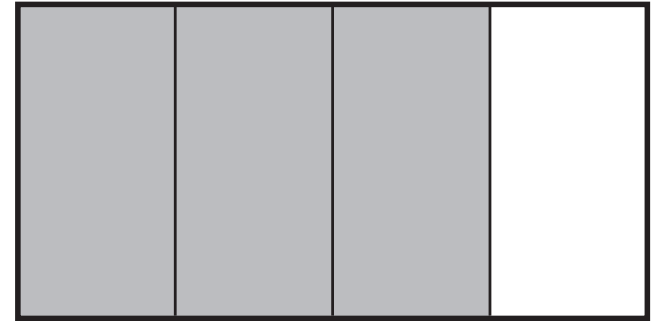

d) 1 unit

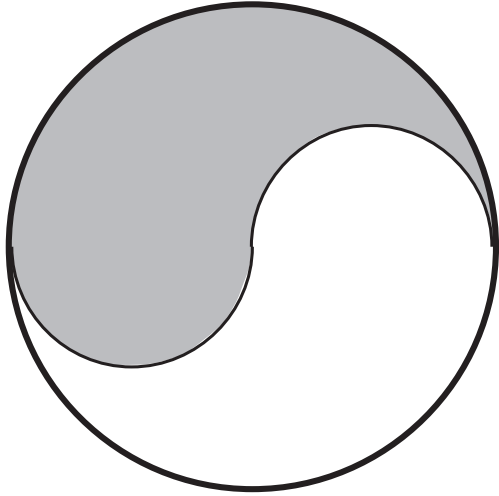

e) 1 unit

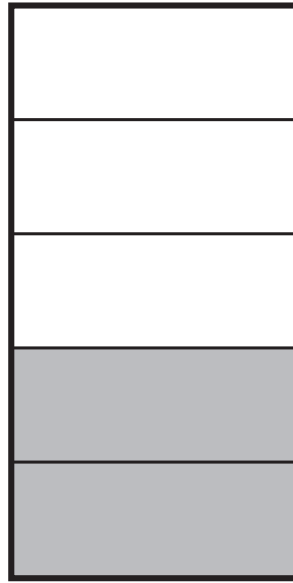

f) 1 unit

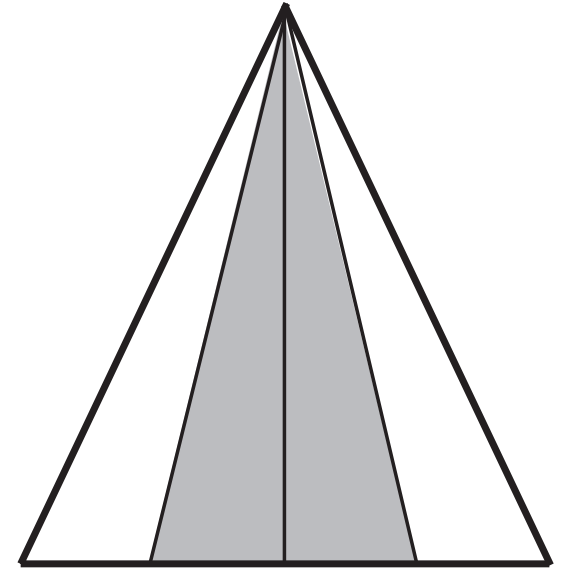

$\frac{1}{3}$

0.5

 $\frac{1}{4}$
 $\frac{5}{9}$

0.3

0.6

0.7

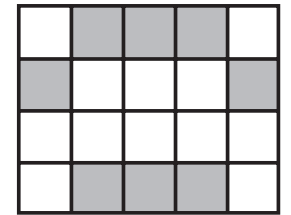
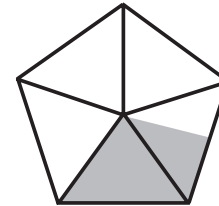
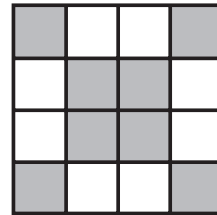
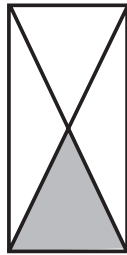
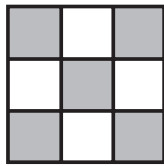
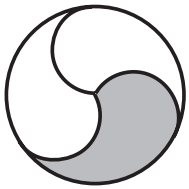

0.25

 $\frac{1}{2}$
 $\frac{3}{4}$
 $\frac{3}{10}$
 $\frac{8}{20}$
 $\frac{4}{9}$

0.4

 $\frac{8}{16}$

a) $a + 3.4 = 5.6$

$a = \boxed{}$

b) $b - 3.1 = 0$

$b = \boxed{}$

c) $c + 2.7 = 10$

$c = \boxed{}$

d) $7.8 + d = 12.3$

$d = \boxed{}$

e) $8.2 - e = 6.4$

$e = \boxed{}$

f) $f - 11.9 = 6.3$

$f = \boxed{}$

g) $g + g + 5.4 = 10$

$g = \boxed{}$

h) $0.4 + h = 0.8 - h$

$h = \boxed{}$

i) $\frac{2}{5} + i = 1.3$

$i = \boxed{}$

j) $j - 0.8 = 1\frac{5}{10}$

$j = \boxed{}$

k) $\frac{3}{4} - k = 0.07$

$k = \boxed{}$

$$\frac{3}{9}$$

$$0.3$$

$$\frac{1}{4}$$

$$\frac{4}{10}$$

$$0.4$$

$$\frac{2}{5}$$

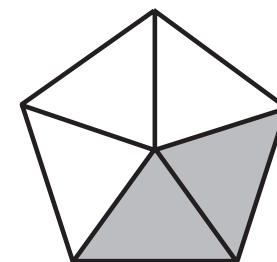
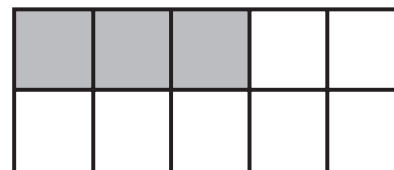
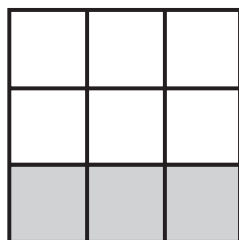
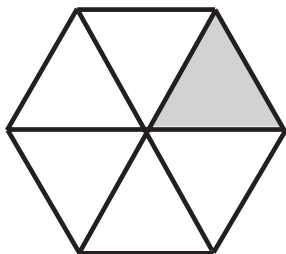
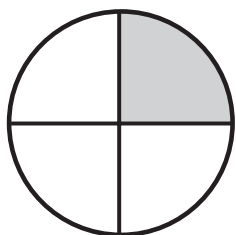

$$\frac{2}{12}$$

$$0.25$$

$$\frac{2}{8}$$

$$\frac{1}{3}$$

$$\frac{1}{6}$$

$$\frac{3}{10}$$

a)
$$\boxed{51 + \square}$$

$$\boxed{193 - 40}$$

b)
$$\boxed{4200 \div 6}$$

$$\boxed{350 + \square}$$

c)
$$5200 - \heartsuit = (620 + 300) \times 2$$

d)
$$(7000 - 2500) \div 9 < \overbrace{\quad\quad} - 300$$

a) $\frac{2}{5}$ m 38 cm

b) 0.7 kg 70 g

c) £200 50 p £200 $\frac{1}{2}$

d) $\frac{3}{4}$ hour 75 min.

e) 48.7 m 48 m 7 cm

f) $2\frac{2}{7}$ weeks 2 weeks 3 days

A	0.9	2508	5 litres 420 ml	457.3	$\frac{1}{5}$	$1\frac{1}{6}$	2 h 43 min
B	$\frac{3}{10}$	8502	2.510 litres	191.8	$\frac{4}{5}$	$3\frac{5}{6}$	3 h 17 min
A + B							

LP 101/4

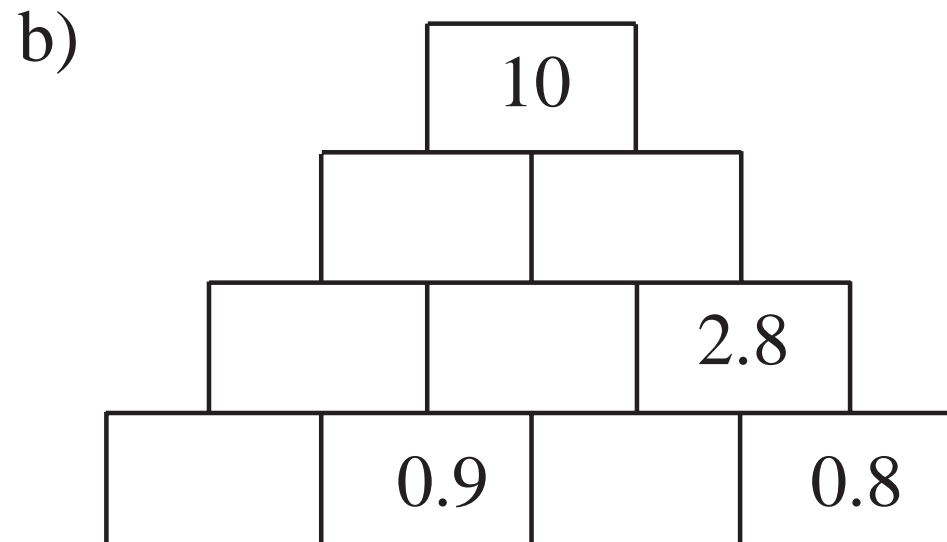
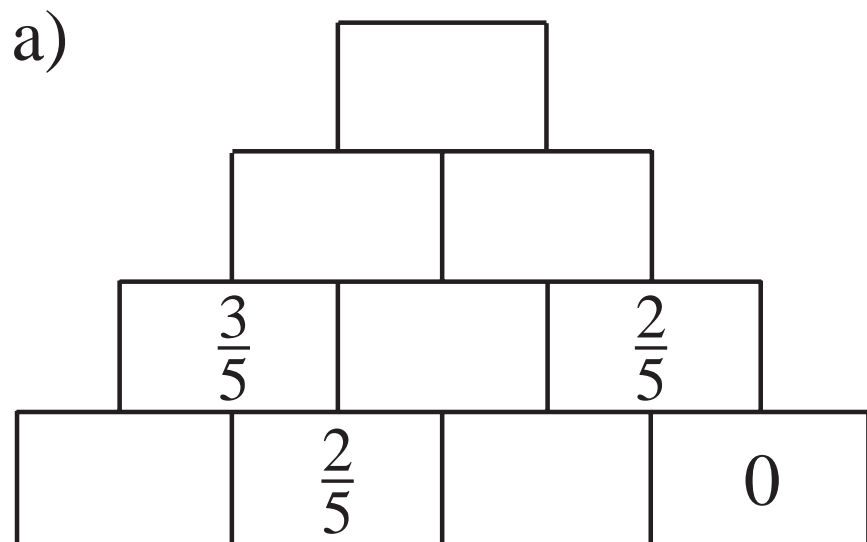

LP 102/2

a)

$\frac{2}{10}$	$\frac{2}{10}$			$\frac{4}{10}$	$\frac{4}{10}$
$\frac{3}{10}$	$\frac{3}{10}$			$\frac{3}{10}$	$\frac{3}{10}$
$\frac{5}{10}$	$\frac{1}{10}$	$\frac{6}{10}$	0	$\frac{4}{10}$	$\frac{1}{10}$
$\frac{5}{10}$	$\frac{1}{10}$	$\frac{6}{10}$	$\frac{2}{10}$	$\frac{4}{10}$	$\frac{3}{10}$
		$\frac{3}{10}$	$\frac{5}{10}$		
		$\frac{3}{10}$	$\frac{5}{10}$		

b)

0.3	0.3	0.3	0.3
0.2	0.3	0.4	0.4
0.5	0.5	0.4	0.1
0.3	0.2	0.2	0.4
0.6	0.3	0.2	0.7
0.2	0.5	0.1	0.3

a)

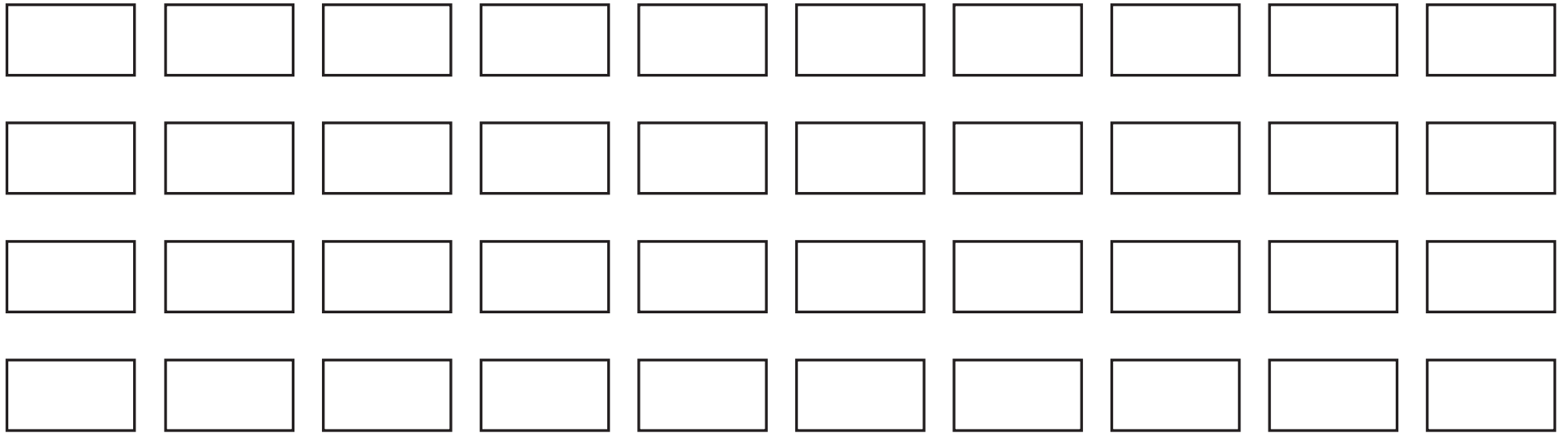

b)



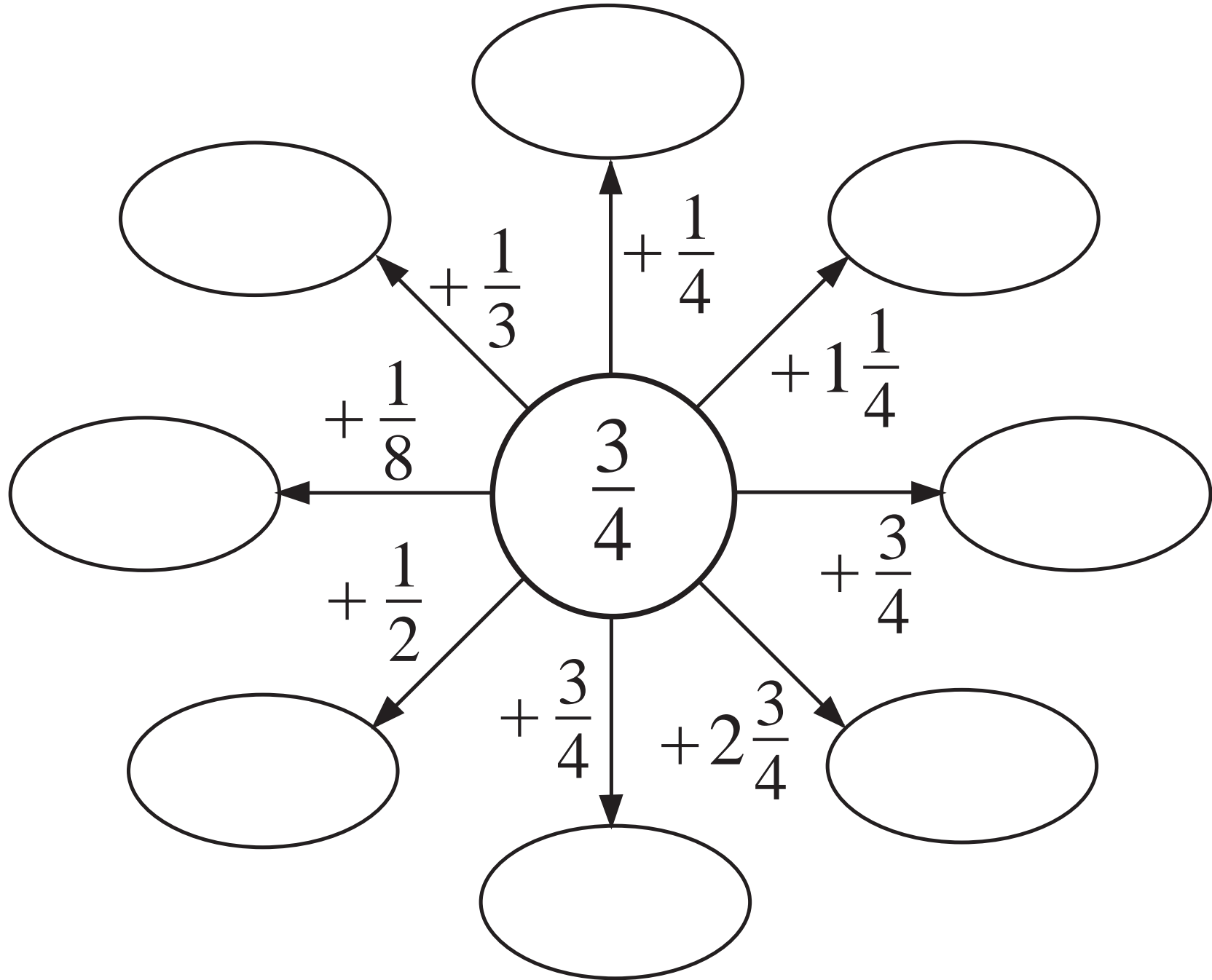

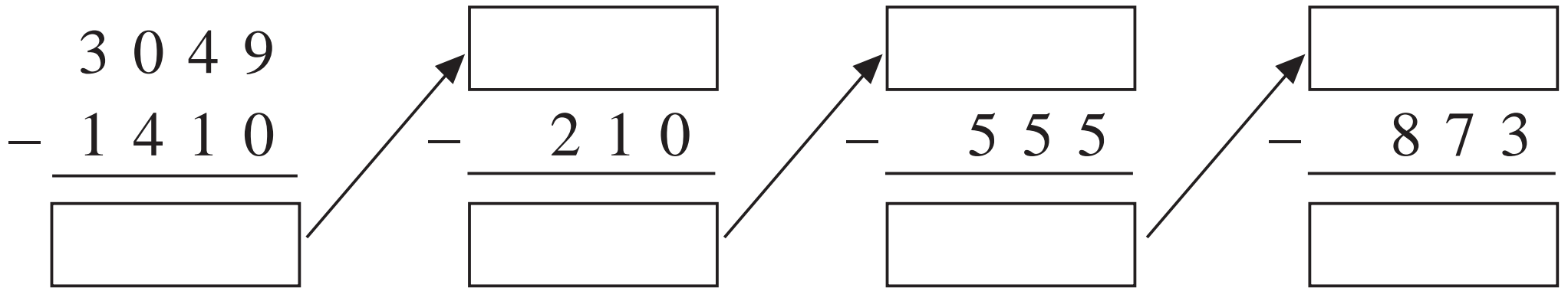

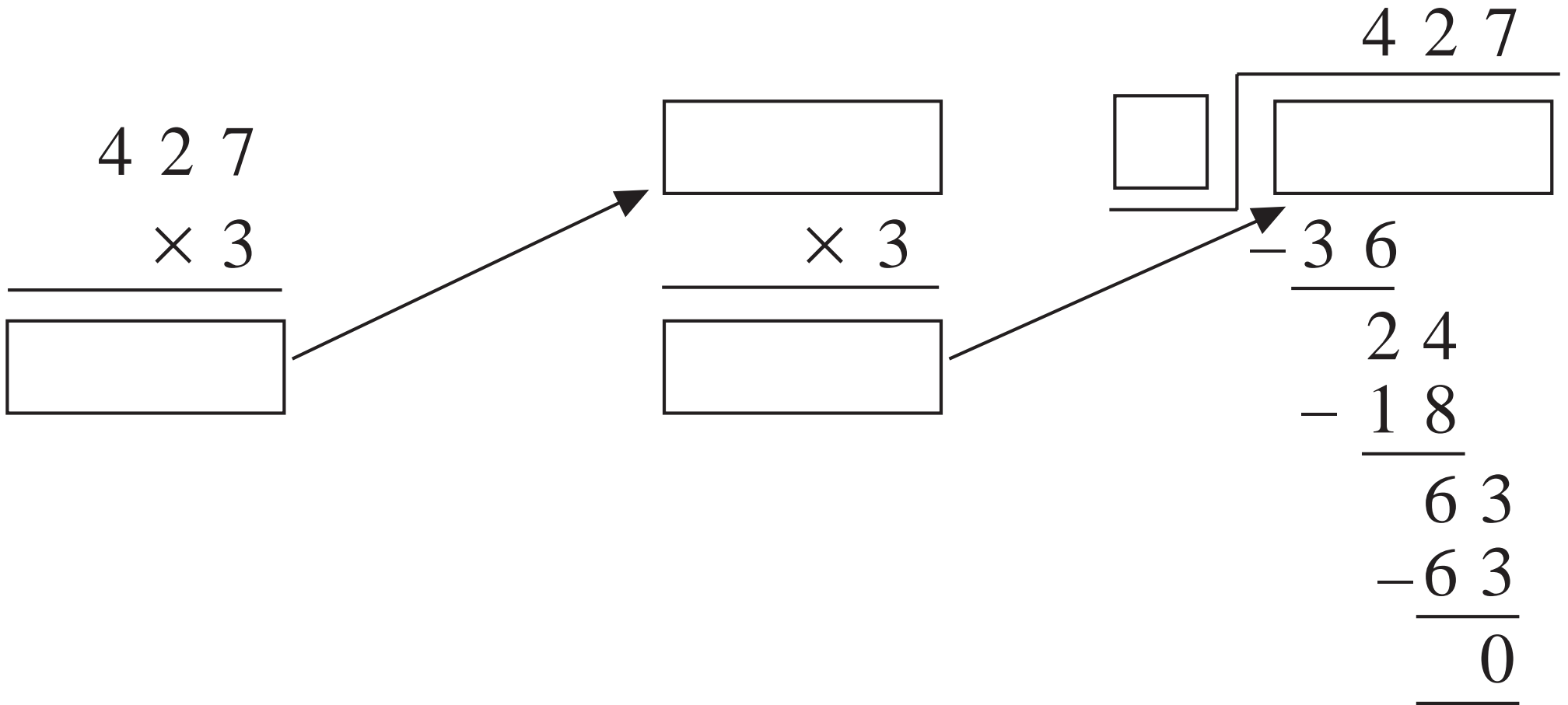

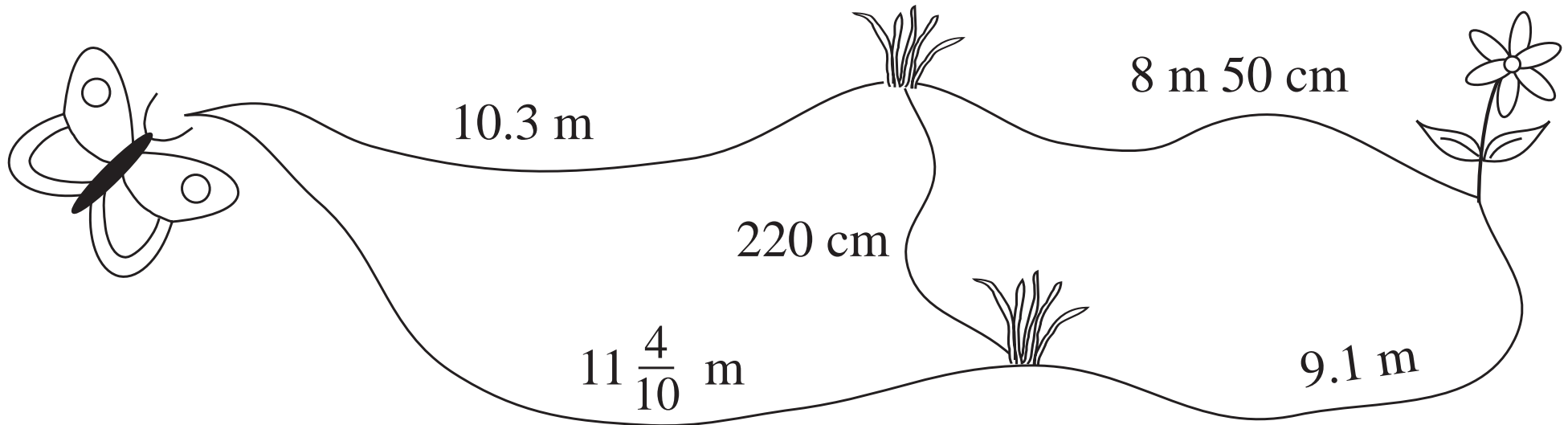

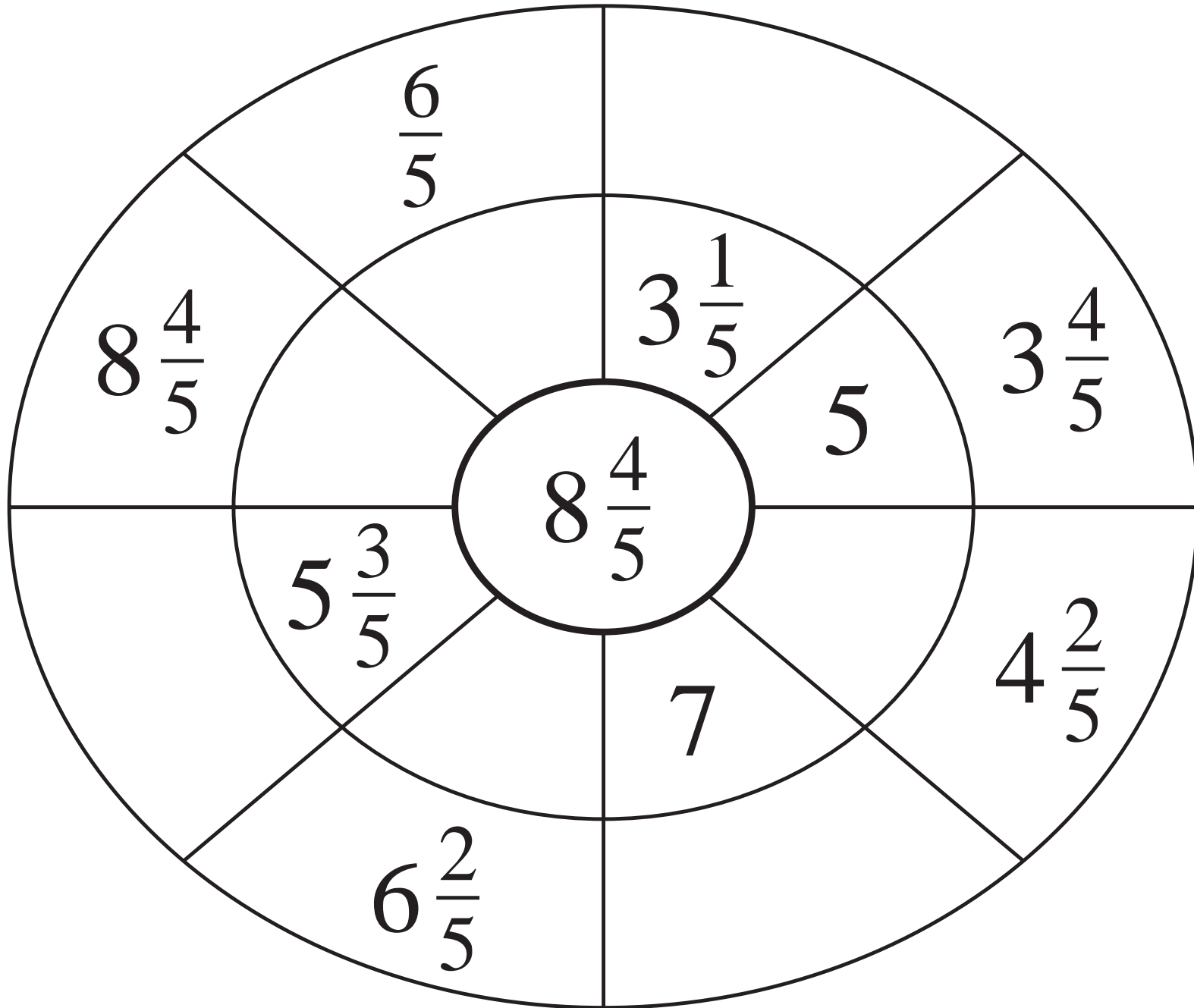

a)

$$40 \text{ cm} = \boxed{} \text{ mm}$$

$$508 \text{ cm} = \boxed{} \text{ mm}$$

$$70 \text{ m} = \boxed{} \text{ cm}$$

$$68 \text{ m} = \boxed{} \text{ cm}$$

b)

$$30 \text{ mm} = \boxed{} \text{ cm}$$

$$8060 \text{ mm} = \boxed{} \text{ cm} = \boxed{} \text{ m } \boxed{} \text{ cm}$$

$$7800 \text{ cm} = \boxed{} \text{ m}$$

$$520 \text{ cm} = \boxed{} \text{ m } \boxed{} \text{ cm} = \boxed{} \text{ mm}$$

a)

$$73 \text{ litres} = \boxed{} \text{ cl}$$

$$57 \text{ cl} = \boxed{} \text{ ml}$$

$$6.2 \text{ kg} = \boxed{} \text{ g}$$

$$5.8 \text{ litres} = \boxed{} \text{ cl}$$

b)

$$40 \text{ ml} = \boxed{} \text{ cl}$$

$$93 \text{ ml} = \boxed{} \text{ cl } \boxed{} \text{ ml} = \boxed{} \text{ cl}$$

$$1800 \text{ g} = \boxed{} \text{ kg } \boxed{} \text{ g} = \boxed{} \text{ kg}$$

$$450 \text{ cl} = \boxed{} \text{ litres } \boxed{} \text{ cl} = \boxed{} \text{ litres}$$

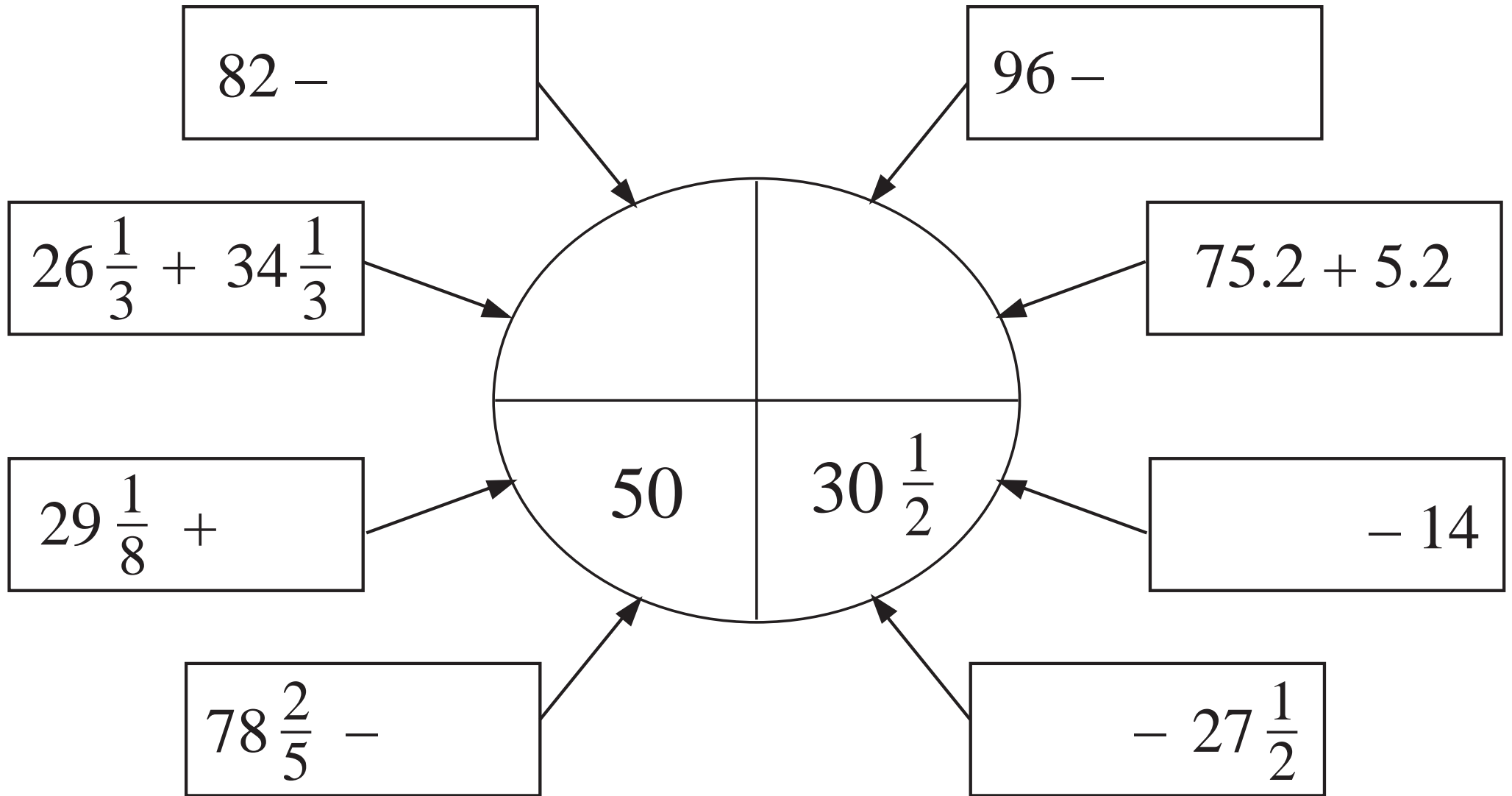

a)

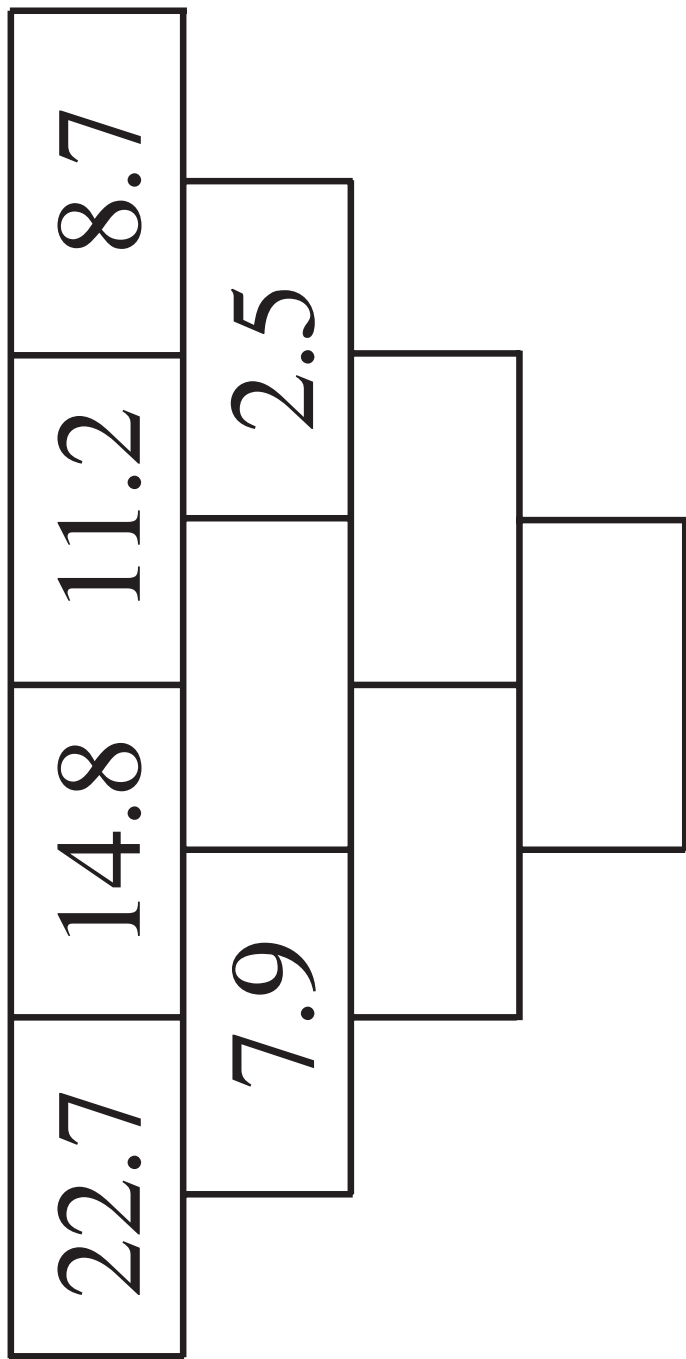

b)

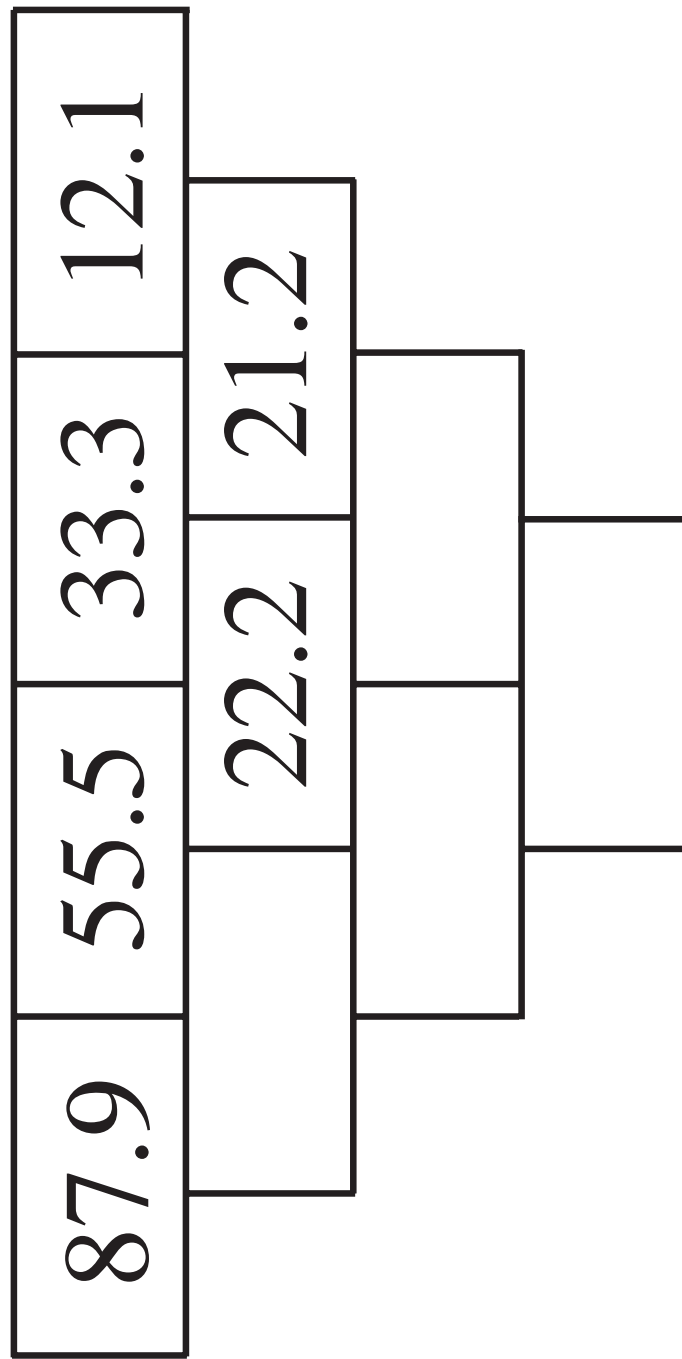

a)

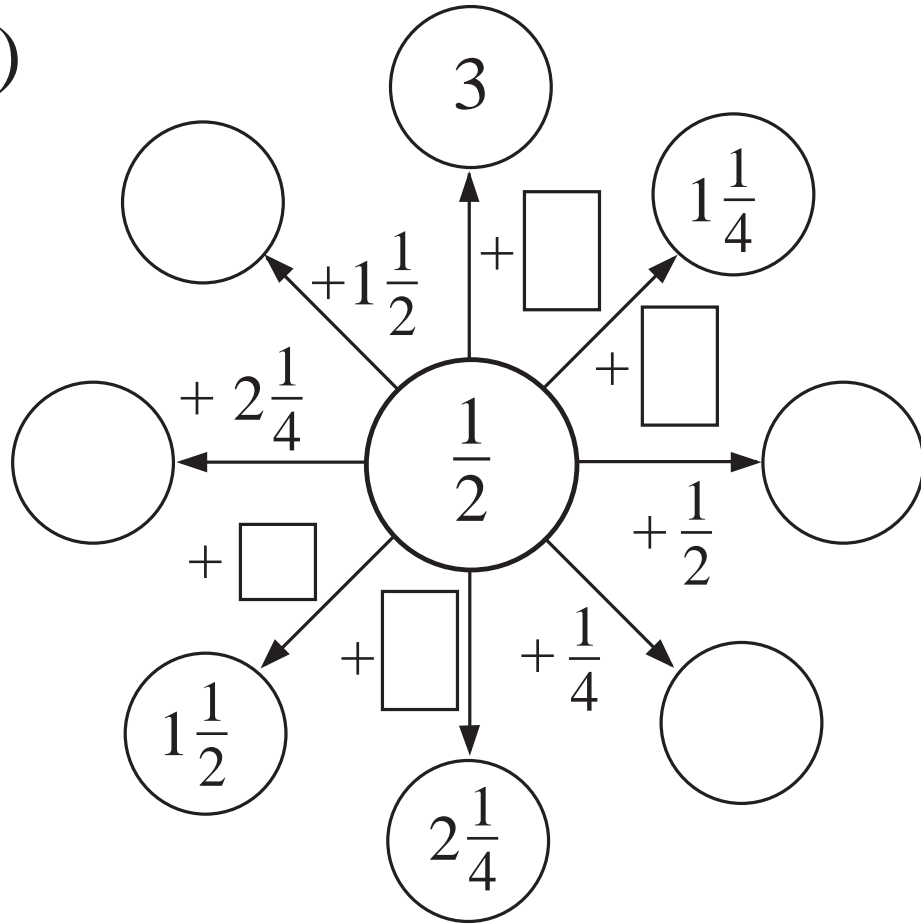

b)

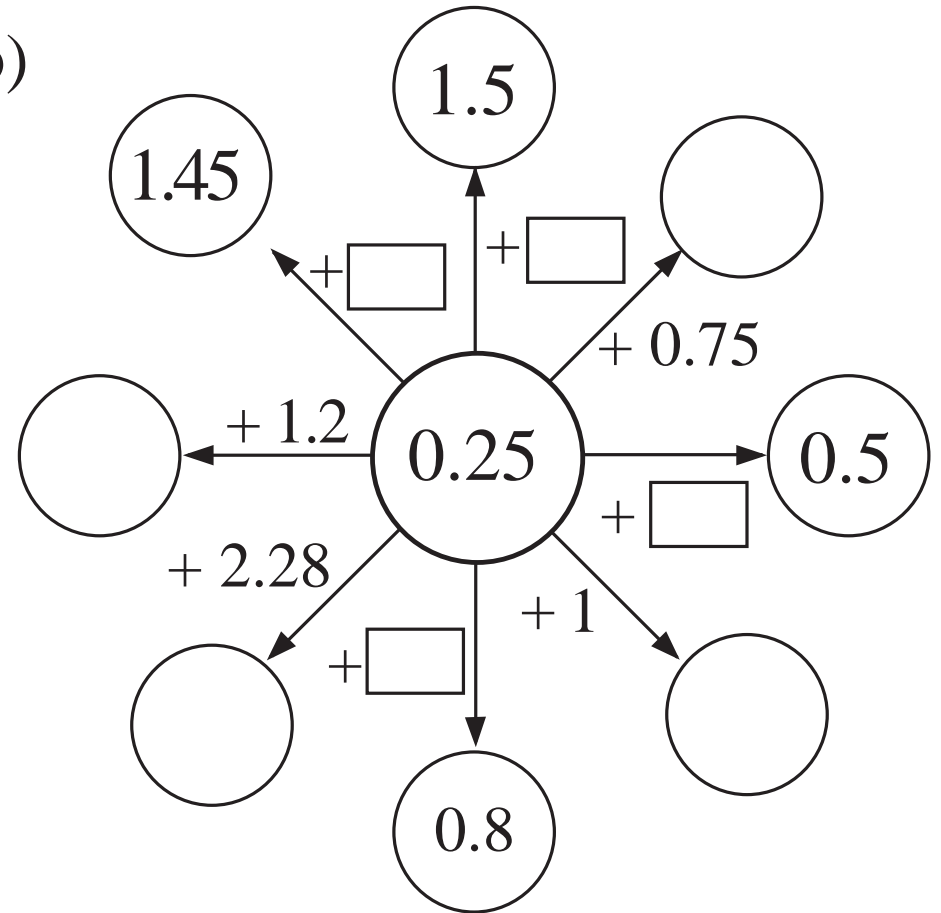

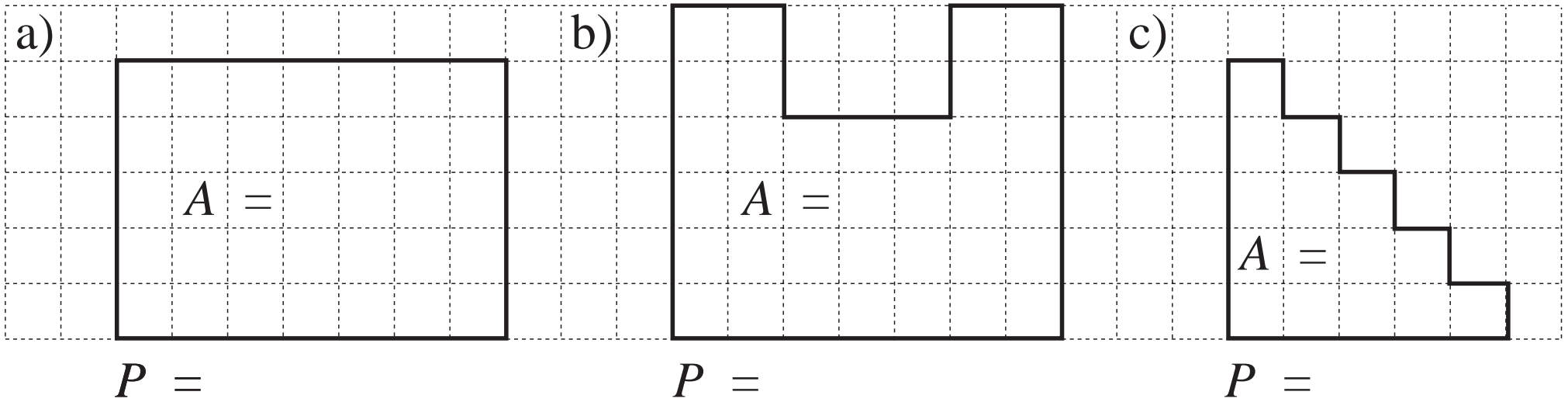

LP 106/4

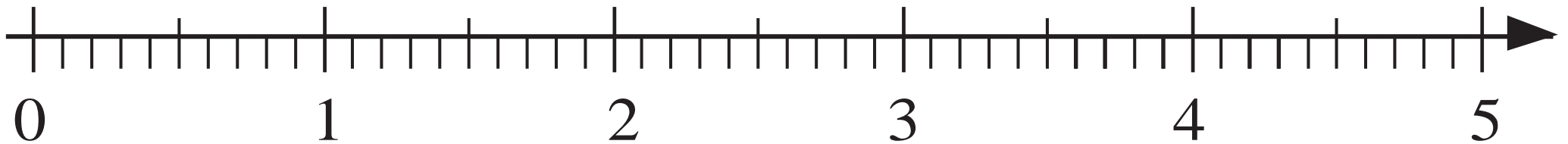

LP 107/1

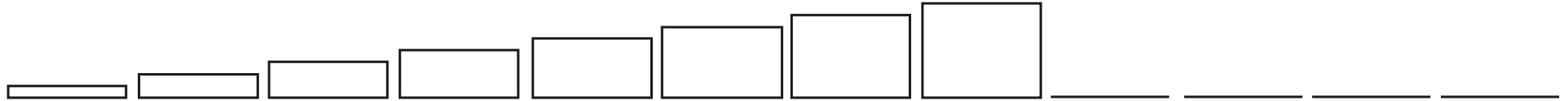

a	1	1	1	1	1	1	1	1	1	1	1	1
b	0.1	0.2	0.3	0.4	0.5	0.6	0.7	0.8	0.9			
P	2.2	2.4										
A	0.1	0.2										

$$P =$$

$$a =$$

$$b =$$

$$A =$$



$$A = 1.3 \text{ m}$$

$$B = 1 \text{ m } 35 \text{ cm}$$

$$C = 134 \text{ cm}$$

$$D = 1350 \text{ mm}$$

$$E = 1 \text{ m } 340 \text{ mm}$$

$$F = 1 \frac{34}{100} \text{ m}$$

$$G = 140 \text{ cm}$$

$$H = 1 \text{ m } 36 \text{ cm}$$

$$I = 1 \text{ m } 400 \text{ mm}$$

$$J = 1.34 \text{ m}$$

130	131	132	133	134	135	136	137	138	139	140	cm

a)

4	1	7
	6	6

	3	8	1
4	2	0	6

8	3	9
5	0	4

6	0	9	2
		5	2

2	3	4	5
7	6	5	4

b)

	7	8
2	0	6

5	2	9	3
	7	5	4

6	4	3
2	0	8

5	0	8	2
	4	3	5

7	8	3	4
1	8	5	6

LP 107/5

a)

2	1	3	×	3

2	0	2	1	×	4

	3	6	4
		×	7

	5	5	5
		×	6

b)

4	8	4	8

3	9	0	3	6

6	3	6	4	2

7	8	8	8

LP 107/6

0.9 , $1.3 + 2.7$, -2 , 0 , 5016 , $7\frac{3}{4} - 1\frac{3}{4}$, $4 - 9$, $2 + \frac{1}{5}$, $408 - \frac{7}{10}$

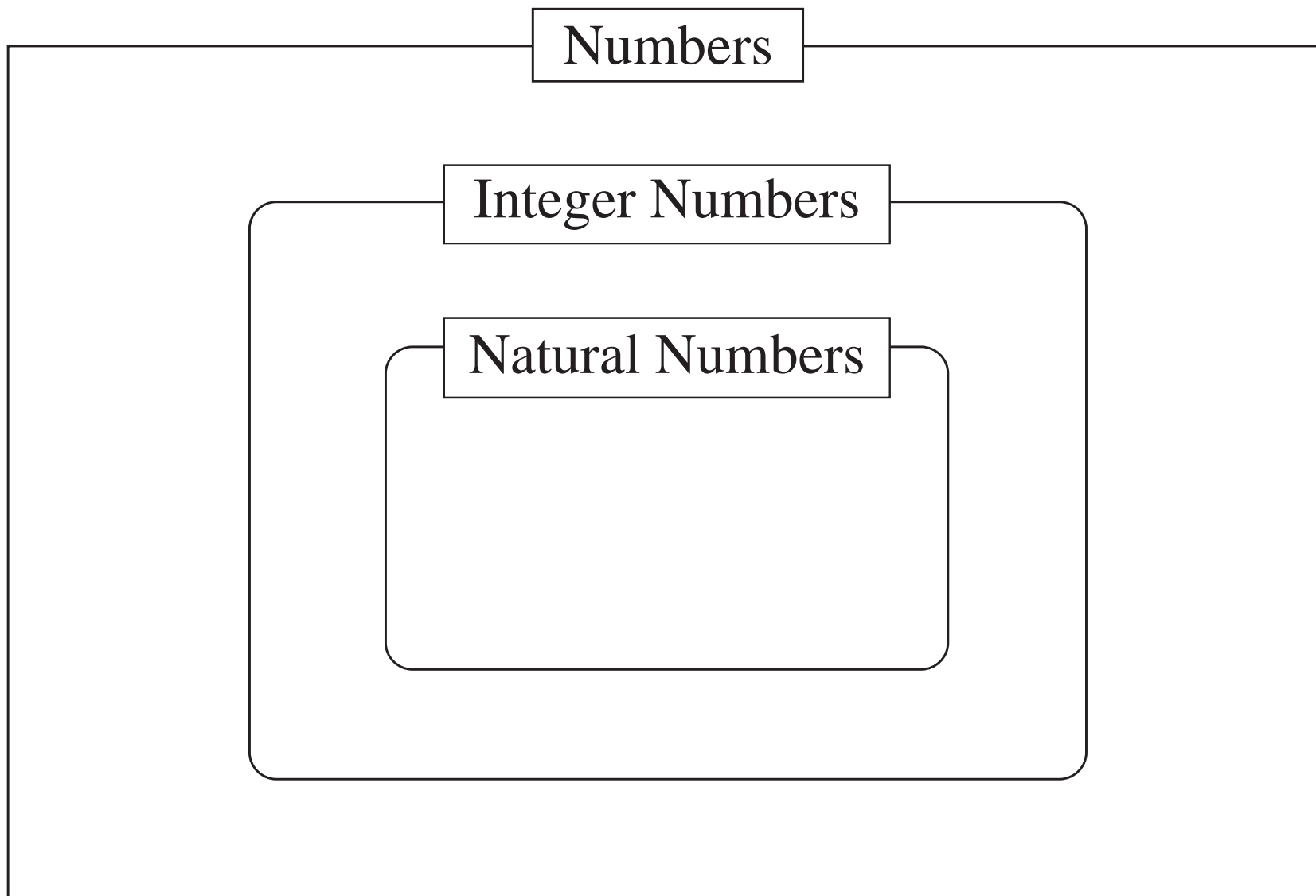

a)

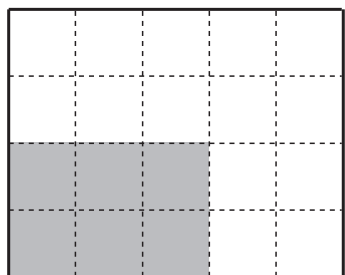

1

b)

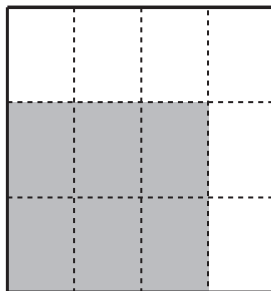

1

c)



1

a)

 9000

$4000 + \boxed{}$

$3900 + \boxed{}$

$\boxed{} + 850$

$\boxed{} + 67$

$1 + \boxed{}$

b)

 12

$5.6 + \boxed{}$

$12 + \boxed{}$

$3\frac{1}{5} + \boxed{}$

$\boxed{} + 11\frac{2}{3}$

c)

 16

$8 \times \boxed{}$

$4 \times \boxed{}$

$\boxed{} \times 1$

$\boxed{} \div 3$

$0.5 \times \boxed{}$

a) **tens**

$$\square < 5420 < \square$$

$$\square < 657 < \square$$

$$\square < 43.2 < \square$$

$$\square < 103\frac{7}{8} < \square$$

b) **units**

$$\square < 5420 < \square$$

$$\square < 657 < \square$$

$$\square < 43.2 < \square$$

$$\square < 103\frac{7}{8} < \square$$

c) **tenths**

$$\square < 5420 < \square$$

$$\square < 657 < \square$$

$$\square < 43.2 < \square$$

$$\square < 2.93 < \square$$

d) **hundredths**

$$\square < 5420 < \square$$

$$\square < 657 < \square$$

$$\square < 43.2 < \square$$

$$\square < 2.93 < \square$$

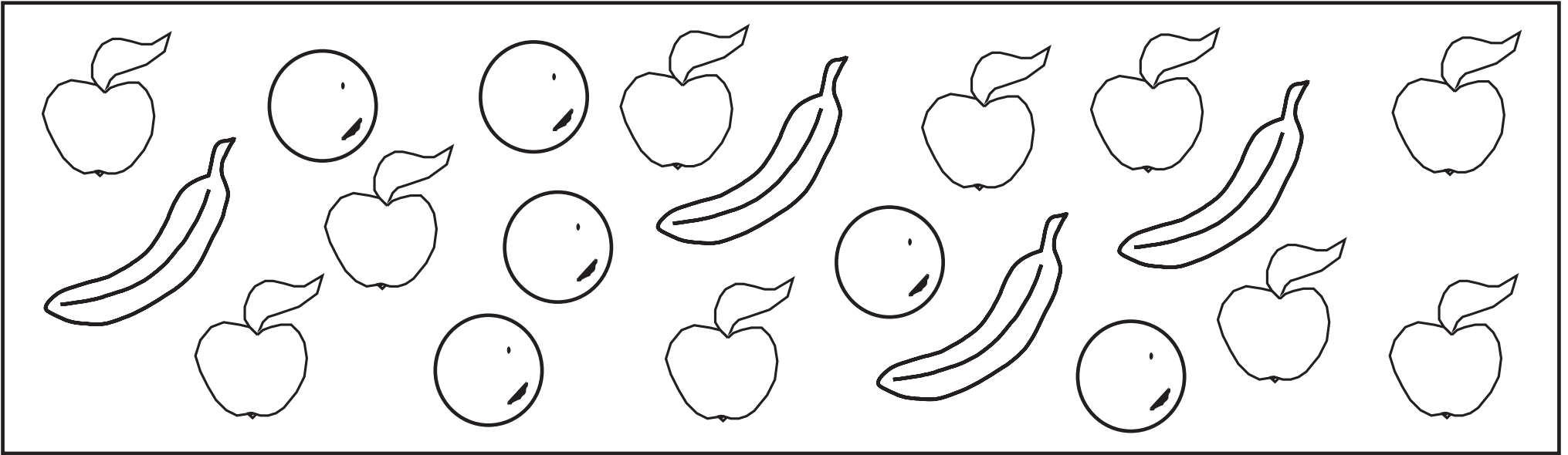





Tally

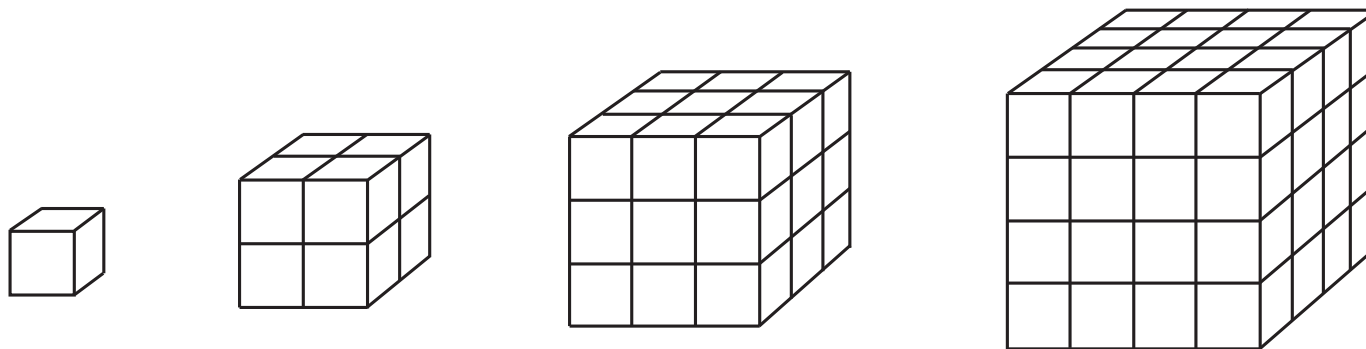

L	1	2	3	4	5	6	7	8	9	10	12	16	(cm)
A													(cm squares)
V													(cm cubes)

LP 109/2



Length of 1 edge 	1	2	3	4	5	6
Area of cube 						
Volume of cube 						

<i>Unit</i>					
<i>Length</i>	1 cm	2 cm	3 cm	4 cm	5 cm
1 cm	①				
2 cm	2	①			
3 cm	3		①		
4 cm	4			①	
5 cm	5				①
6 cm	6				
7 cm	7				
8 cm	8				
9 cm	9				
10 cm	10				
12 cm	11				
16 cm	12				

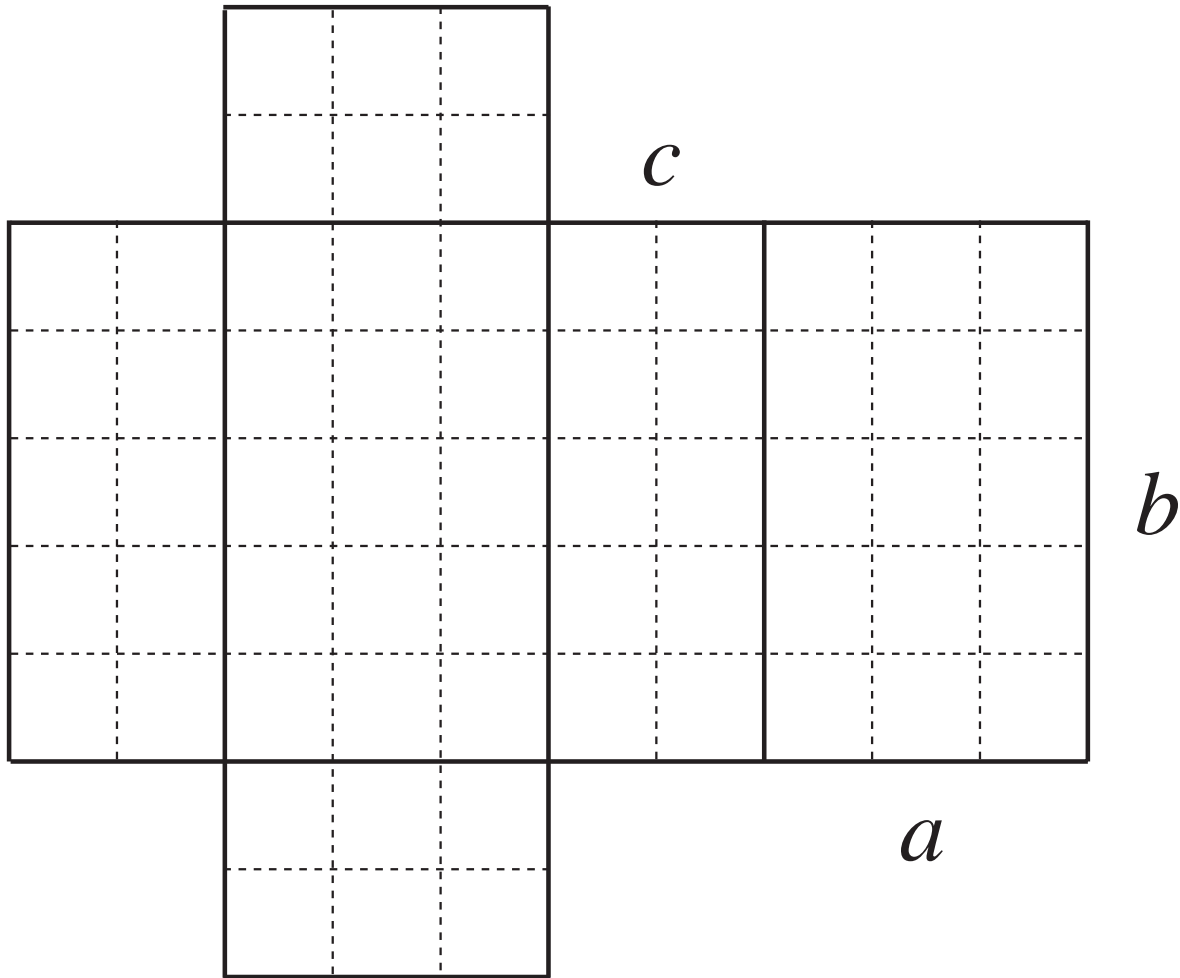

a	b	c	A	V

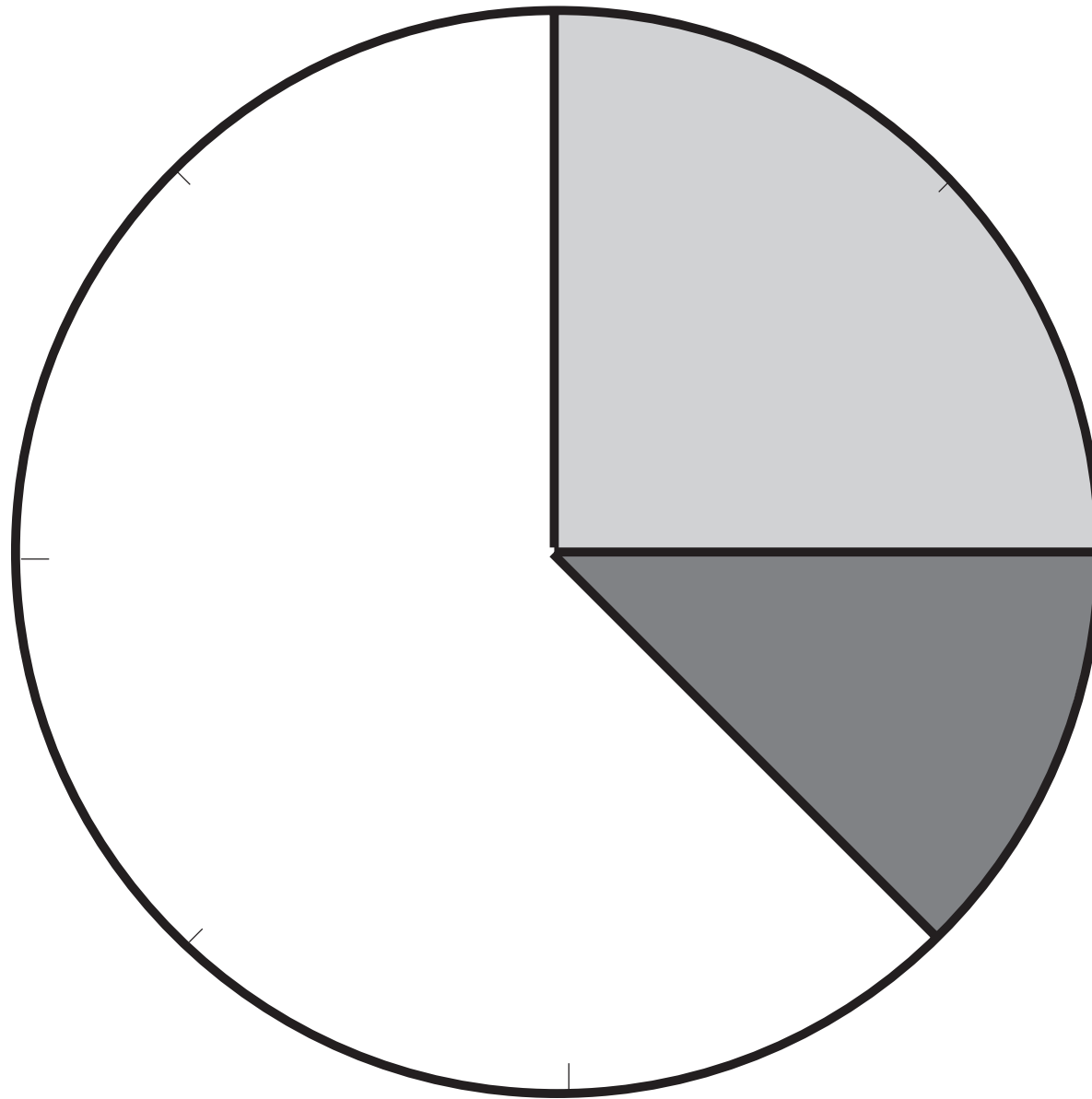

○ Basketball

○ Football

○ Tennis

a) i) $3 + \square = 11$ ii) $\square + 820 = 1000$ iii) $\frac{3}{7} + \square = \frac{6}{7}$
 iv) $\square + \frac{2}{9} = 1$ v) $2.3 + \square = 4$ vi) $\square + 0.6 = 1$
 b) i) $7 - \square = 2$ ii) $\square - 820 = 1000$ iii) $\frac{8}{9} - \square = \frac{2}{9}$
 iv) $\square - \frac{1}{3} = \frac{1}{3}$ v) $4.3 - \square = 3.1$ vi) $\square - 0.6 = 0.4$

LP 109/7

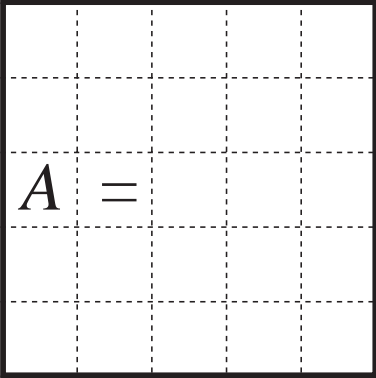
a)  $A =$
 $P =$

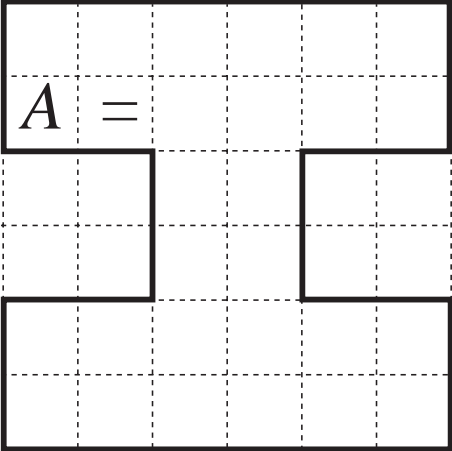
b)  $A =$
 $P =$

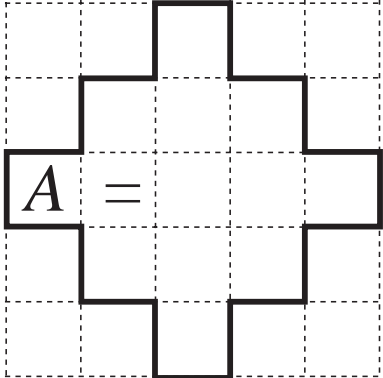
c)  $A =$
 $P =$

LP 110/1