



YEAR 3

Copy Masters



0	1	2	3	4	5	6	7	8	9
10	11	12							
20									
	31								

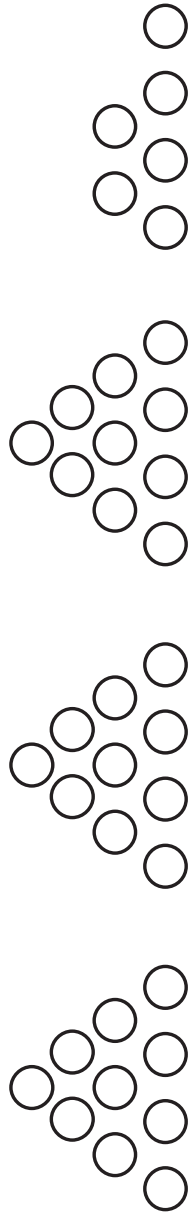

a)

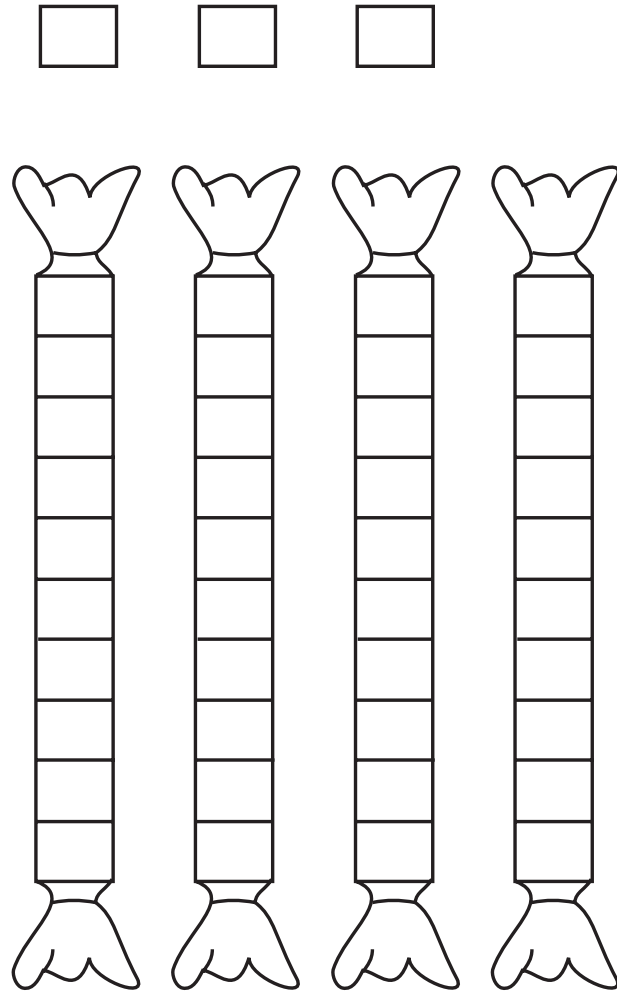

b)

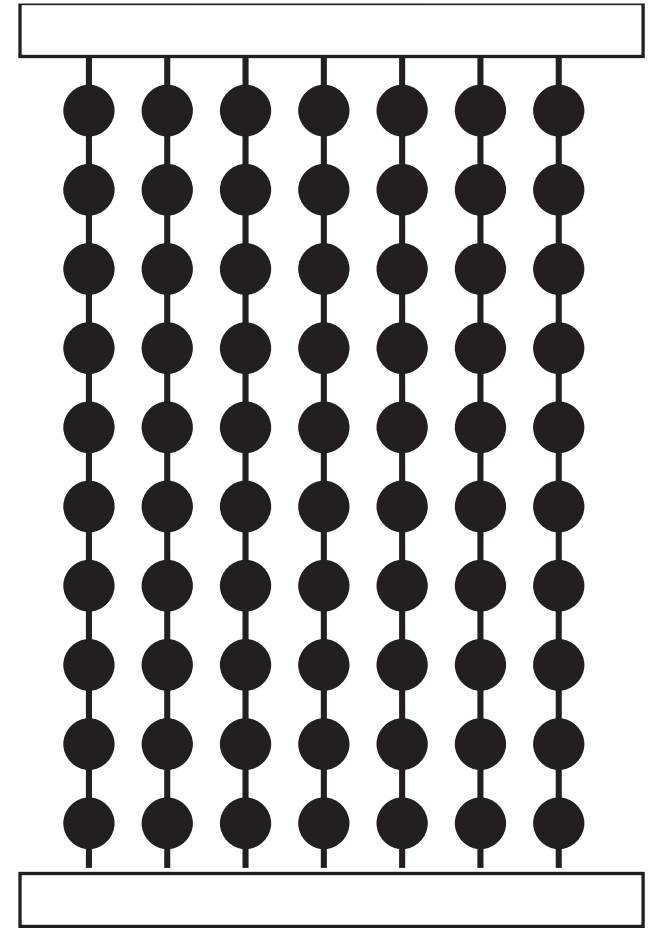

c)

	Hundreds	Tens	Units
a)			
b)			
c)			
Total			

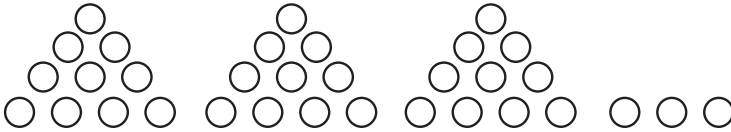
a) 

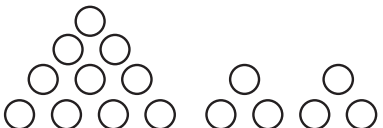
b) 

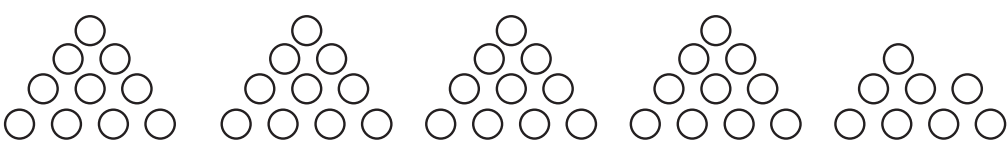





c) 

	H	T	U
a)			
b)			
c)			
Total			

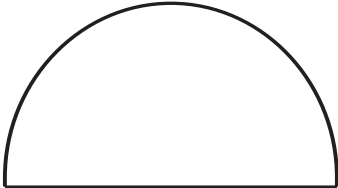
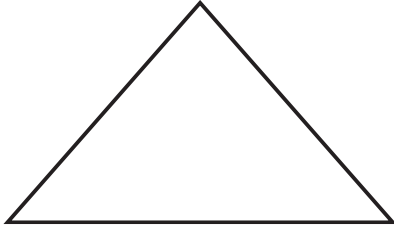
LP 1/5

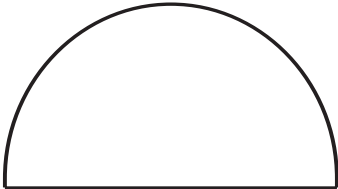
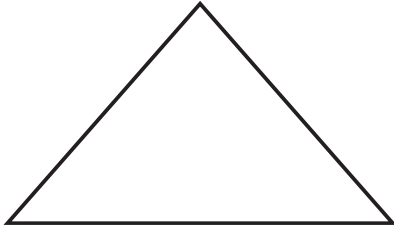
Roman		II		IV		VI	VII		IX	X		XIV		XIX		LV
Arabic	1		3		5			8			11		18		26	73

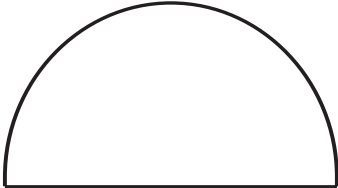
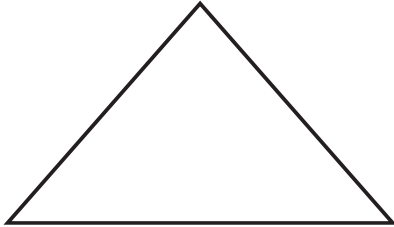
LP 1/6

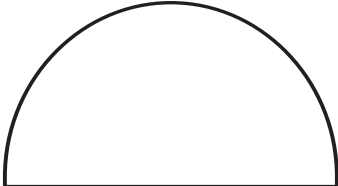
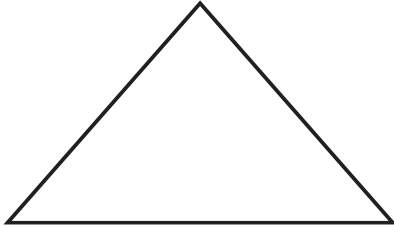
	$+$		$+$		$=$	100
	$+$		$-$		$=$	60
	$-$		$+$		$=$	40
	$-$		$-$		$=$	0

a)

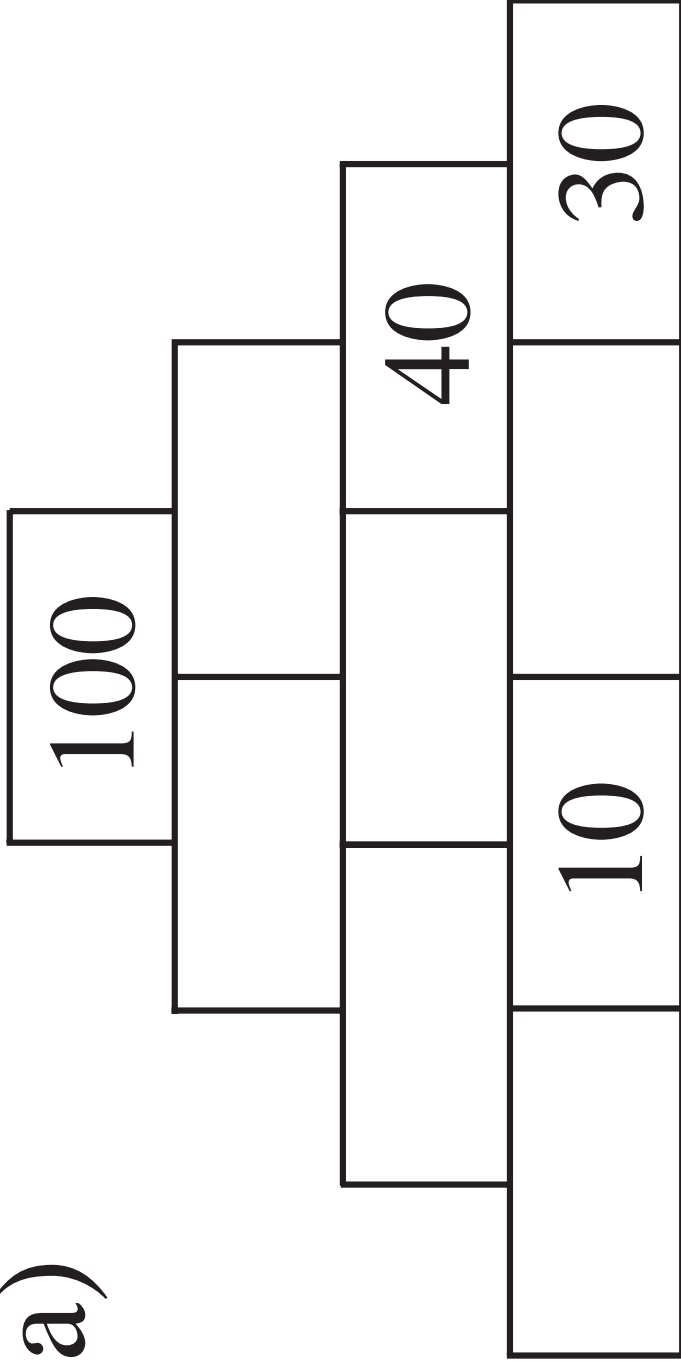

b)

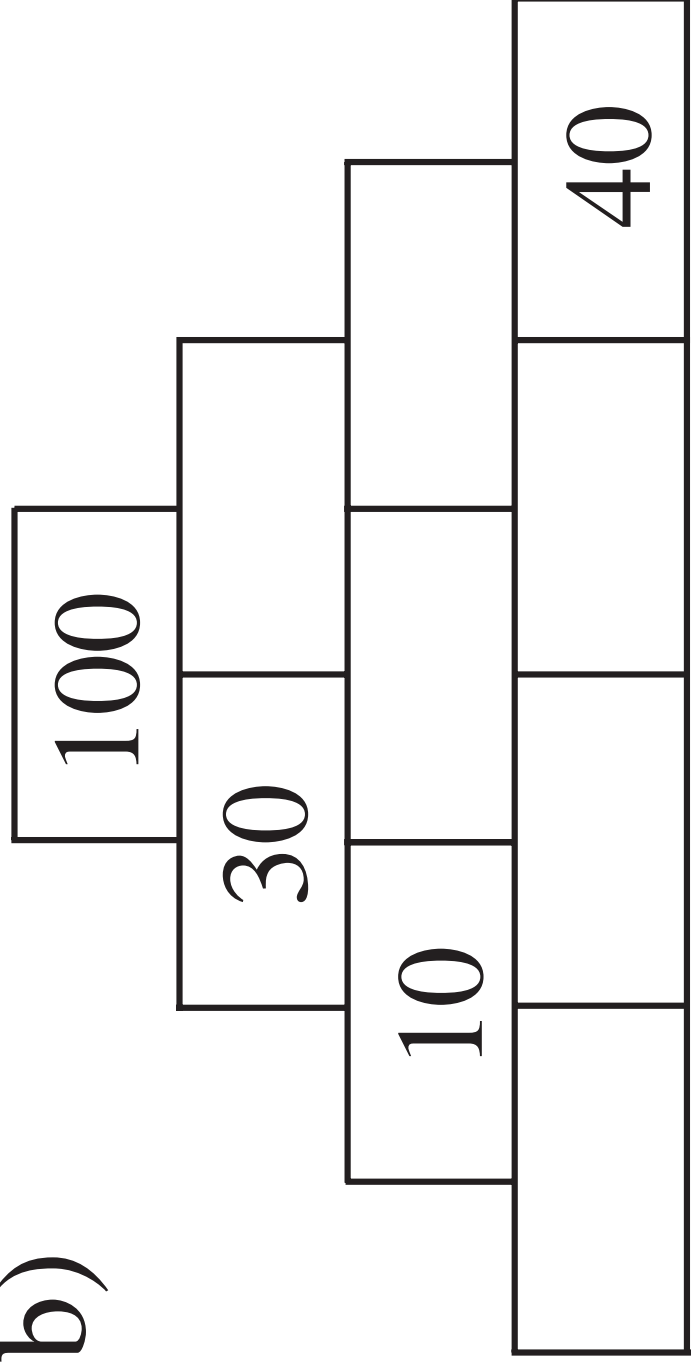

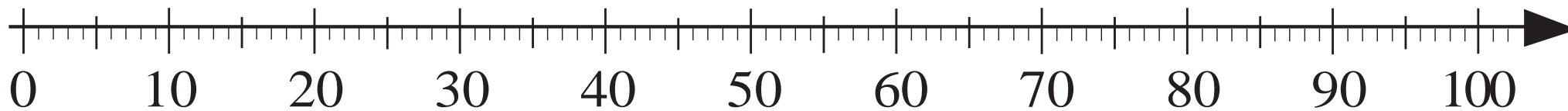

a)

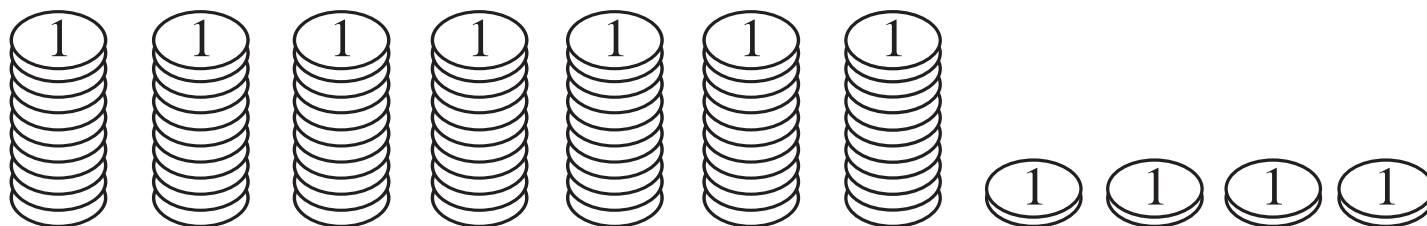

b)

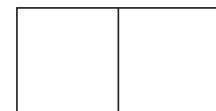
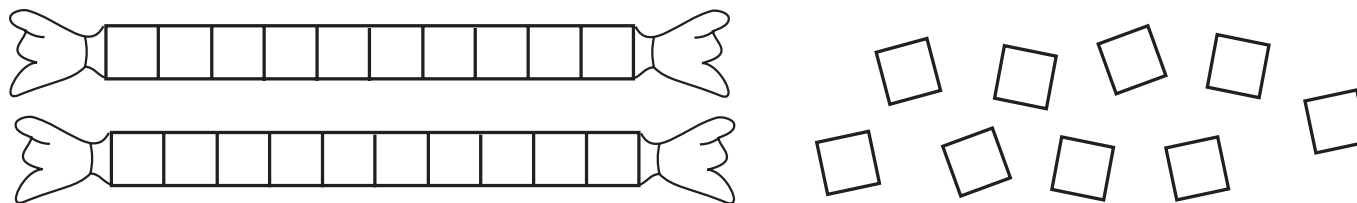

c)

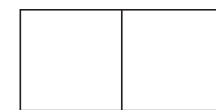
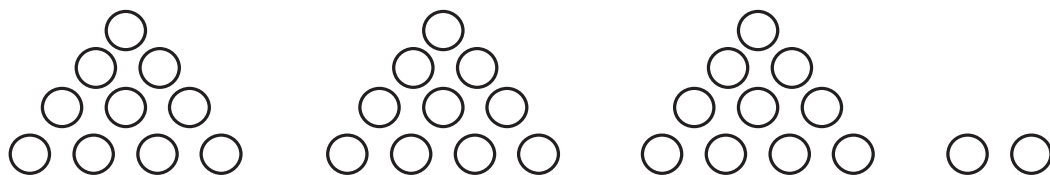



+

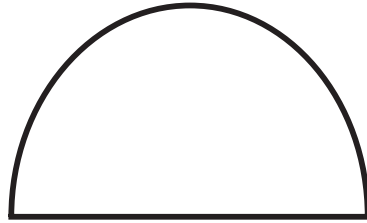

=

100

—

—

—

10

+



=

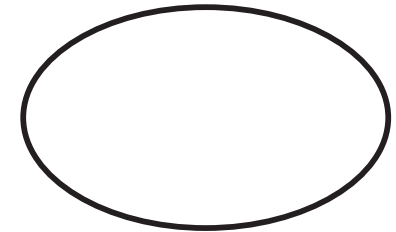

=

=

=

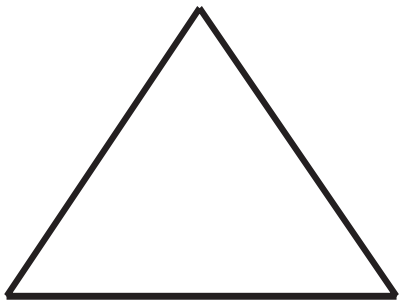

+

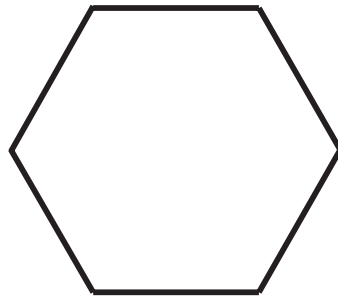

=

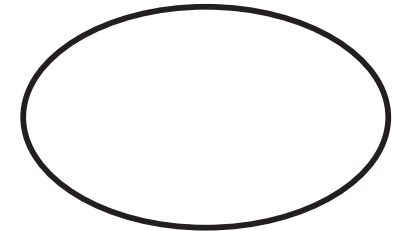

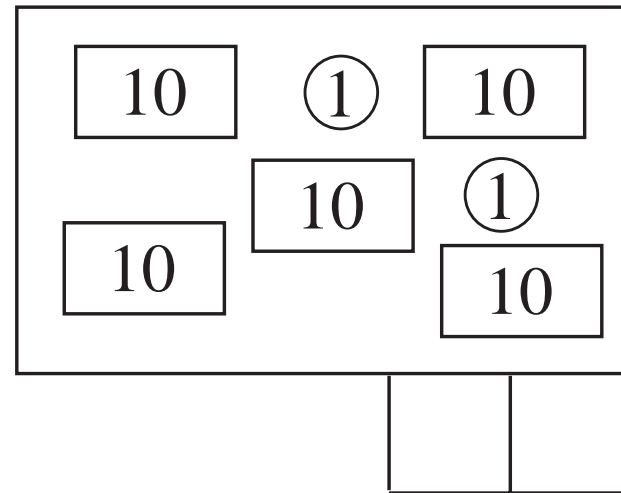
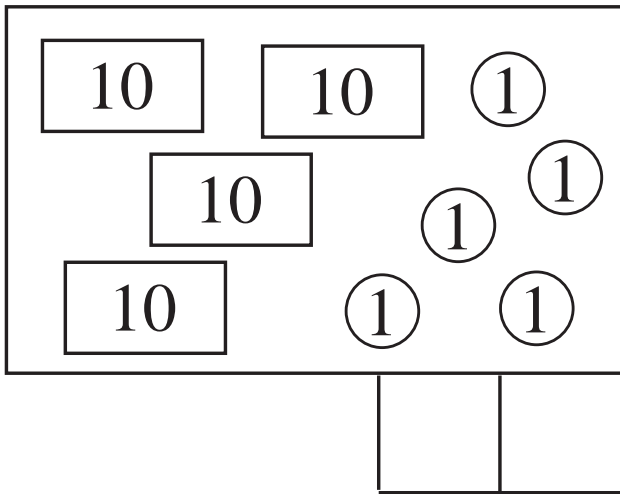
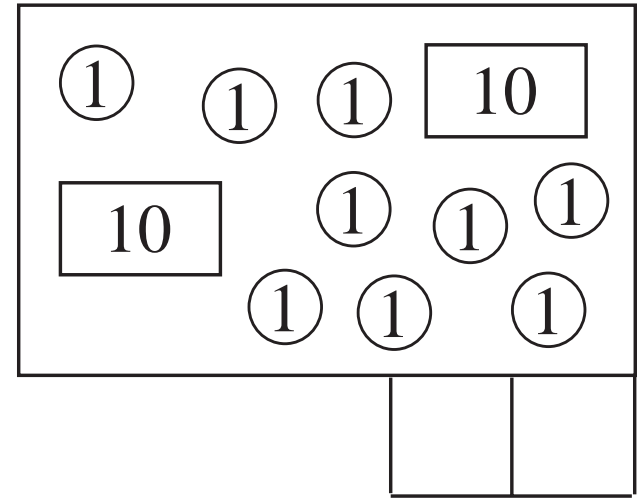
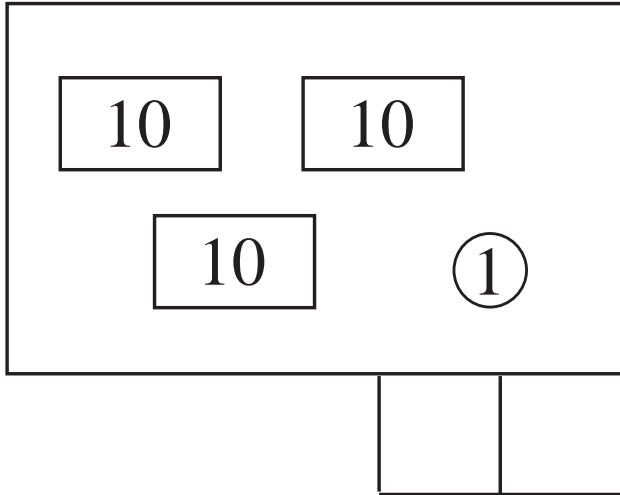

a)

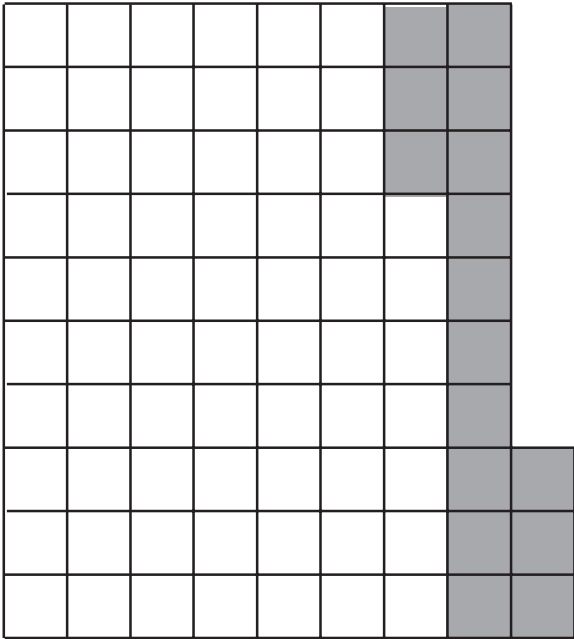

b)

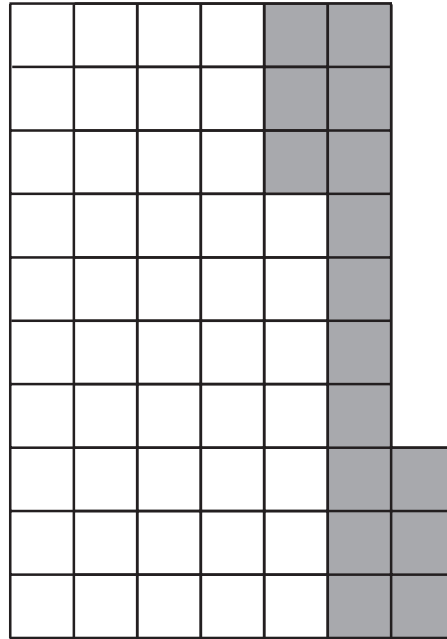

c)

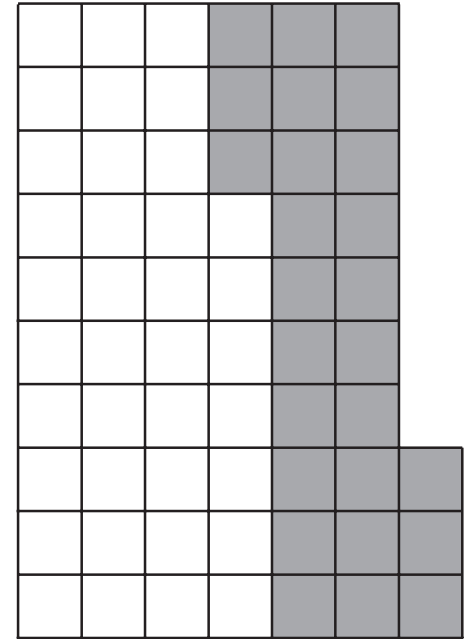

a) $13 + 12 + 12 + 12 = \square + \square + \square + \square$
 $20 + 15 - 13 - 11 = \square - \square - \square - \square$
 $11 + 3 = \square + \square$
 $\square - \square + \square = \square$

b) $26 - 12 + 5 - 10 + 10 - 4 = \square - \square + \square - \square + \square - \square$
 $11 + 15 - 10 - 4 = \square - \square + \square - \square$
 $3 + 23 = \square + \square$
 $\square - \square + \square = \square$

a) $27 - 19 + 2 < 2$ $7 + 8 - \square$

b) $28 - 9 + 3 < 1$ $19 + 6 - \square$

c) $24 - 15 + \square$ $3 > 6 + 5 - 4$

d) $37 - 28 + \square$ $4 > 7 + 6 - 4$

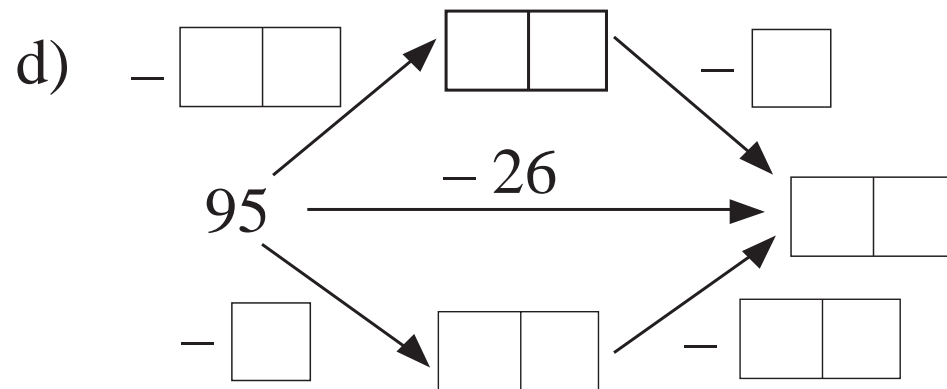
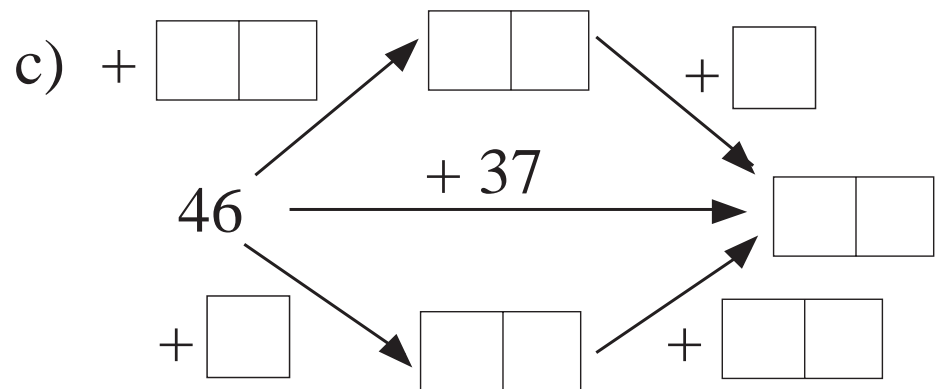
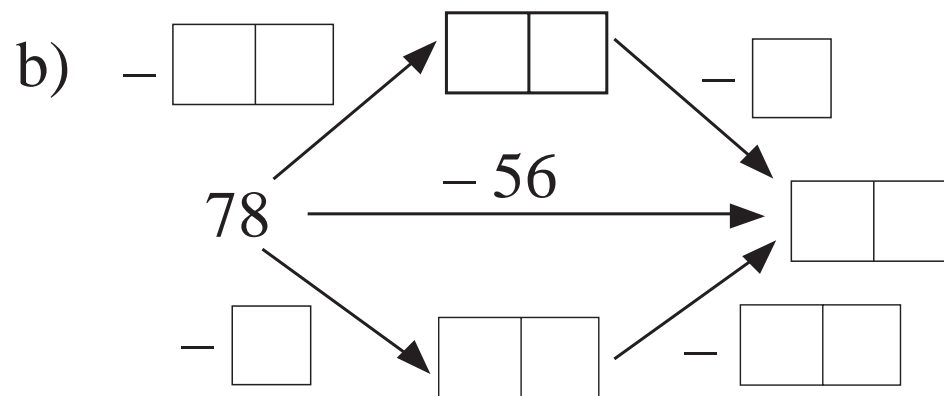
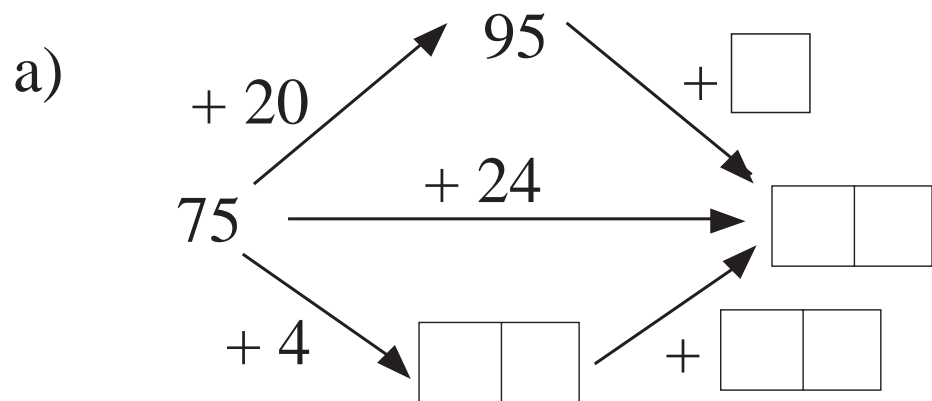

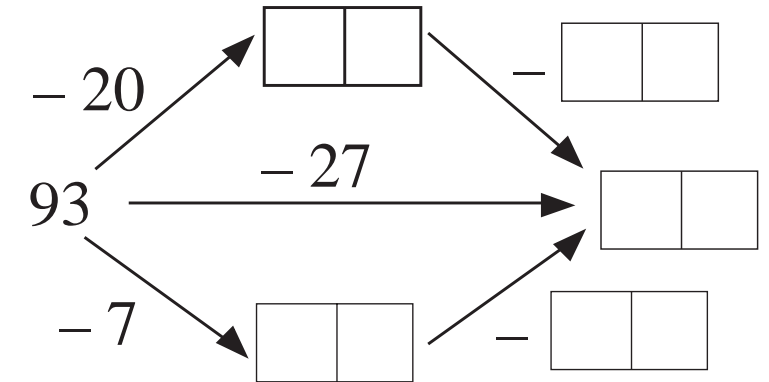
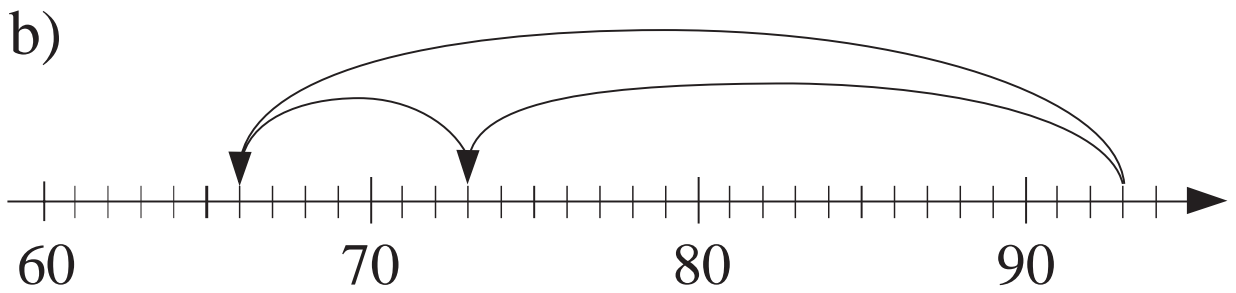
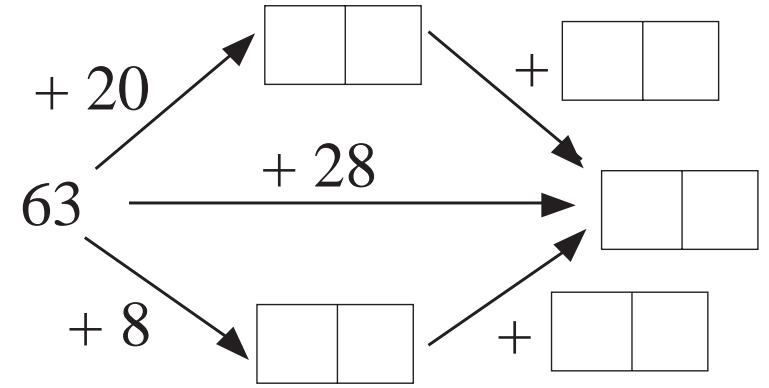
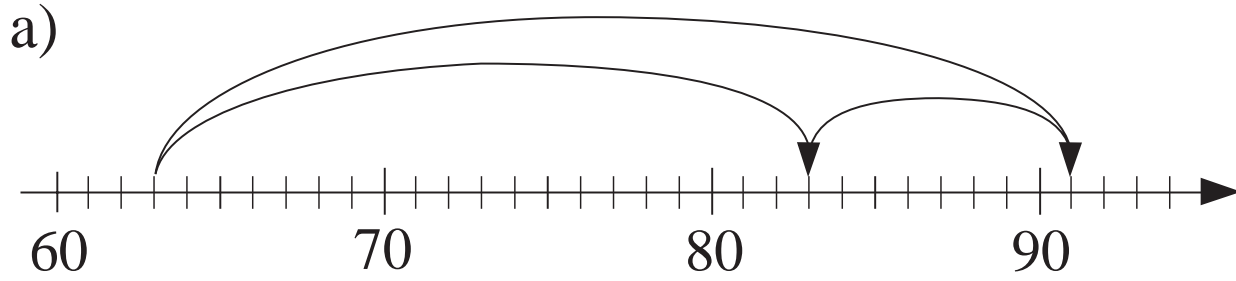



Rounders	24	24	24	24	24	24	24	24	24	24
Football	43	43	43	43	43	43	43	43	43	43
Swings										
Total										

a) i) $34 + 49 =$

ii) $(34 + 5) + 49 =$

iii) $34 + (49 + 5) =$

iv) $(34 + 5) + (49 + 5) =$

v) $(34 - 5) + 49 =$

vi) $34 + (49 - 5) =$

vii) $(34 - 5) + (49 - 5) =$

viii) $(34 + 5) + (49 - 5) =$

ix) $(34 - 5) + (49 + 5) =$

b) i) $91 - 50 =$

ii) $(91 + 5) - 50 =$

iii) $91 - (50 + 5) =$

iv) $(91 + 5) - (50 + 5) =$

v) $(91 - 5) - 50 =$

vi) $91 - (50 - 5) =$

vii) $(91 - 5) - (50 - 5) =$

viii) $(91 + 5) - (50 - 5) =$

ix) $(91 - 5) - (50 + 5) =$

60

18

40

20

35

12

4×5

6×10

9×2

7×5

4×10

6×2

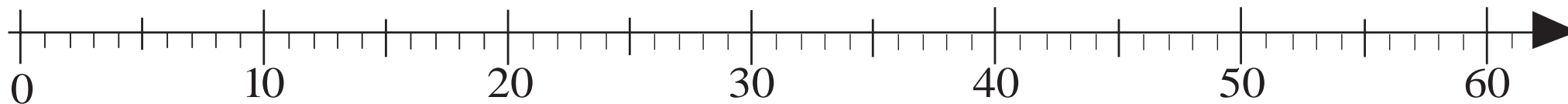

LP 6/3b

x	0	1	2	3	4	5	6	7	8	9	10	11	12	13	14	15
3	0	3														
6	0															
9	0	9														

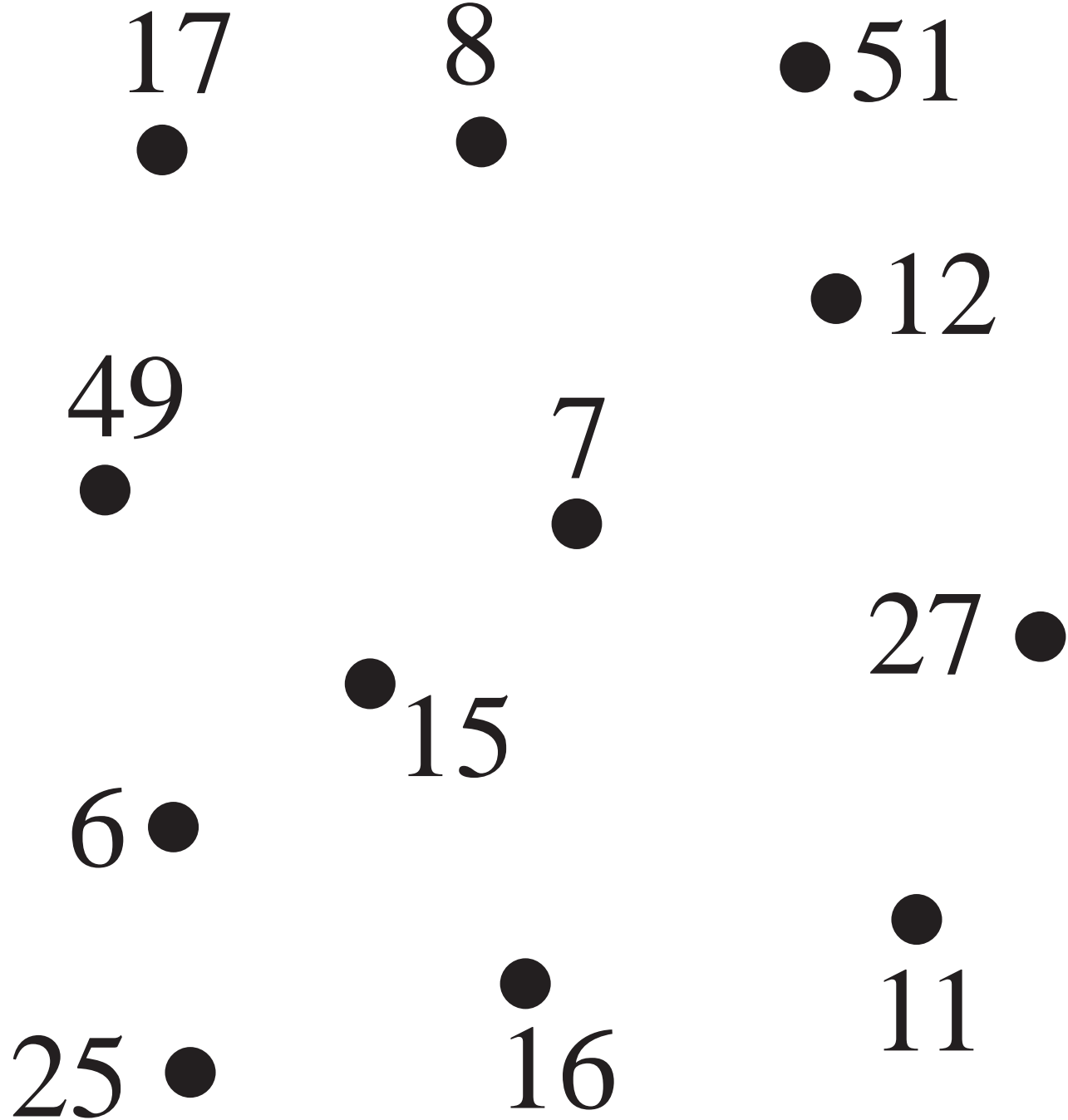

a)

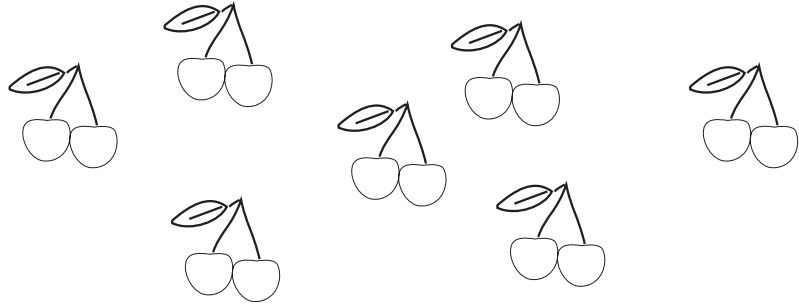

b)

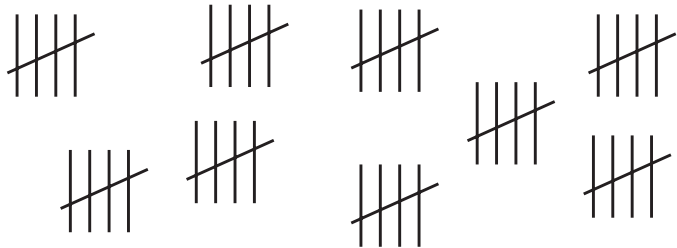

c)

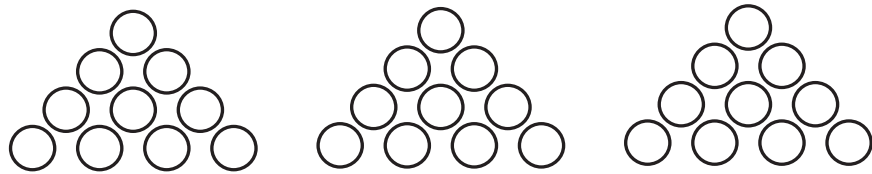

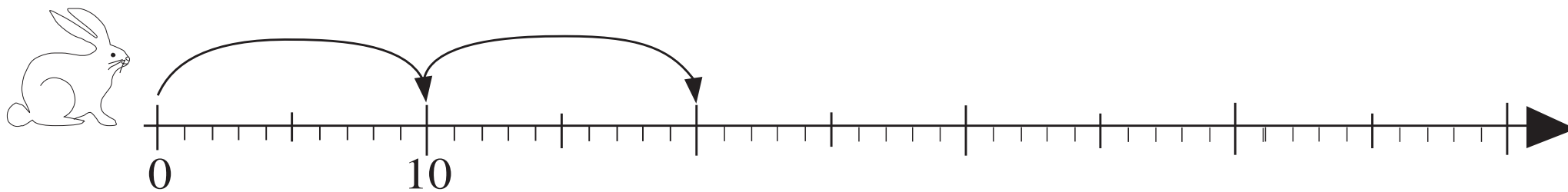
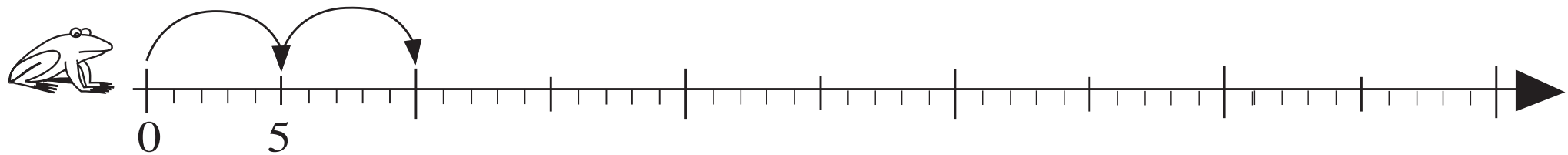
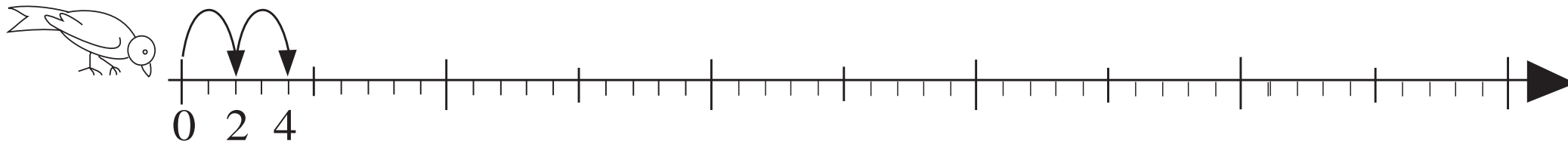



x	0	1	2	3	4	5	6	7	8	9	10
0	0	0	0	0	0	0	0	0	0	0	0
1	0	1	2	3	4	5	6	7	8	9	10
2	0	2									
3	0	3									
4	0	4									
5	0	5									
6	0	6									
7	0	7									
8	0	8									
9	0	9									
10	0	10									

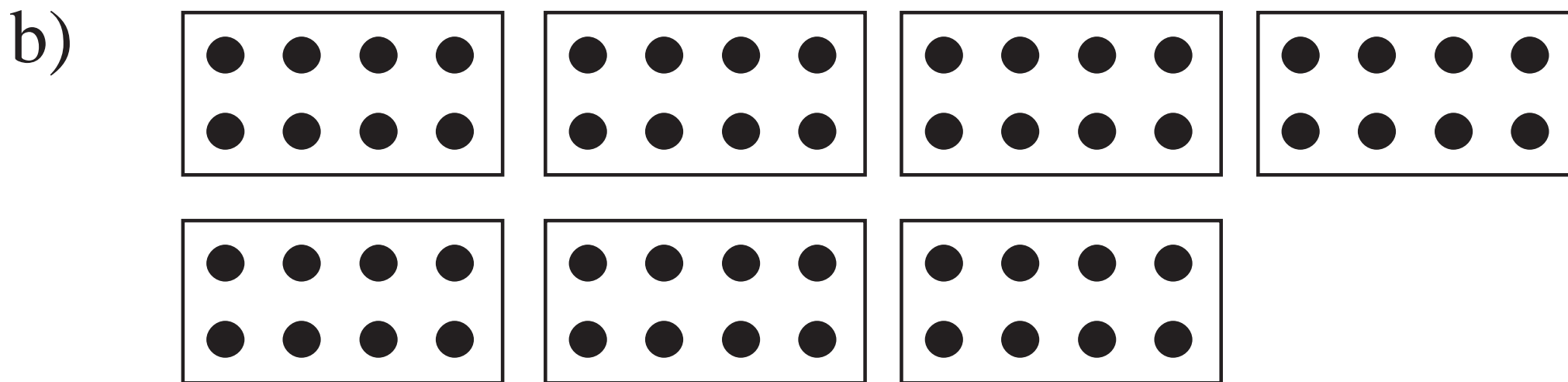
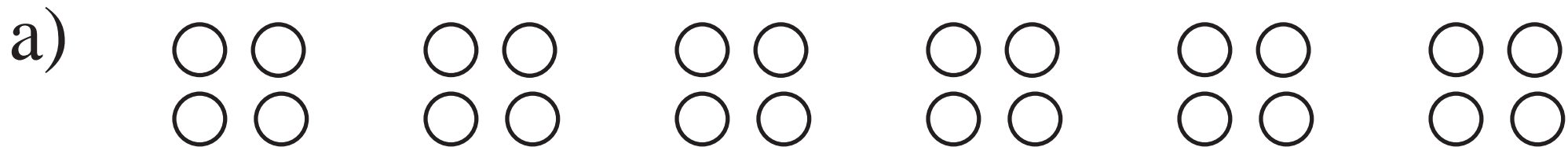

a)

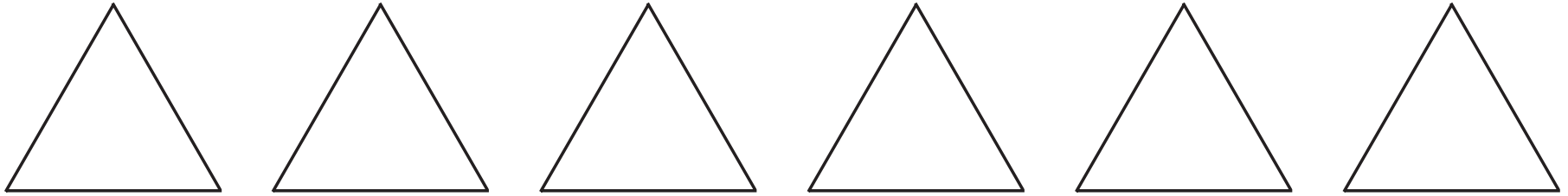

b)

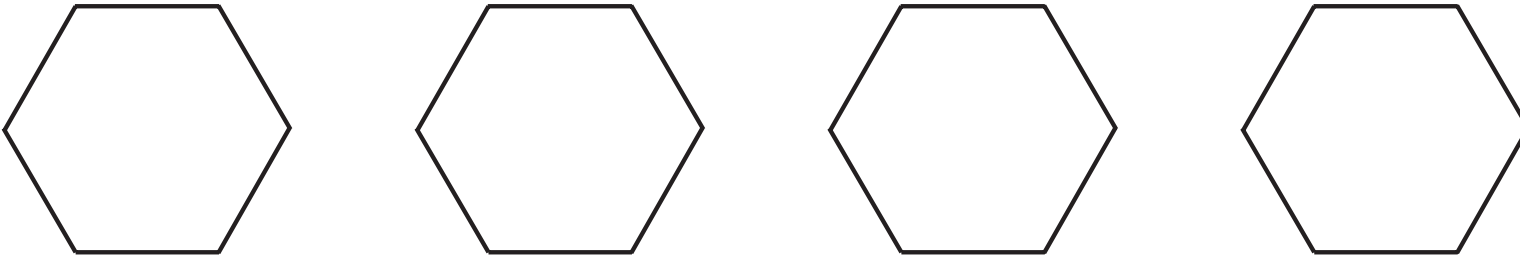

c)

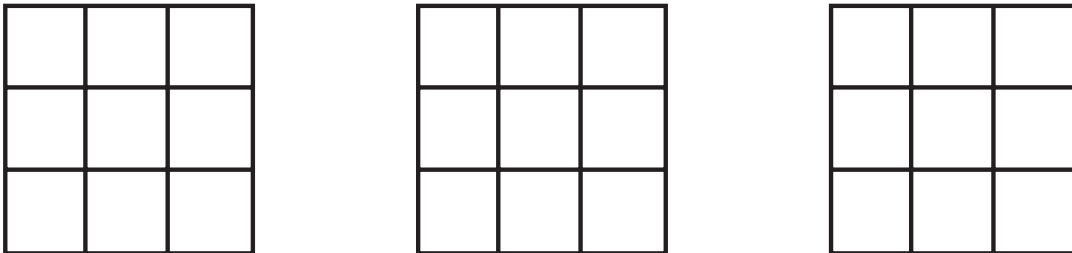

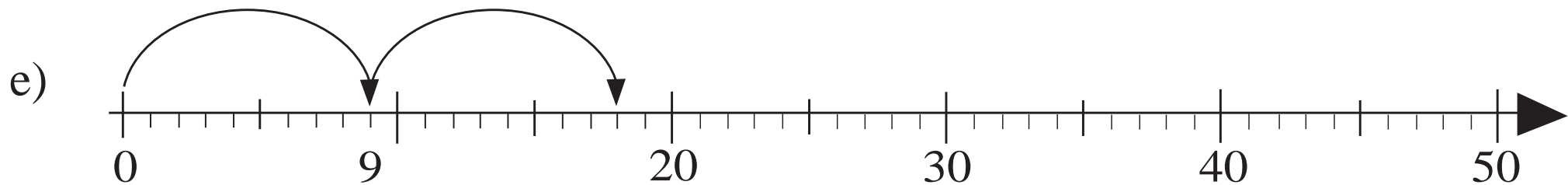
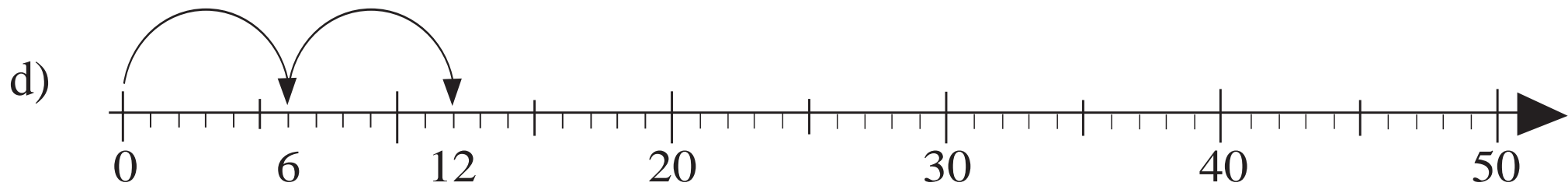
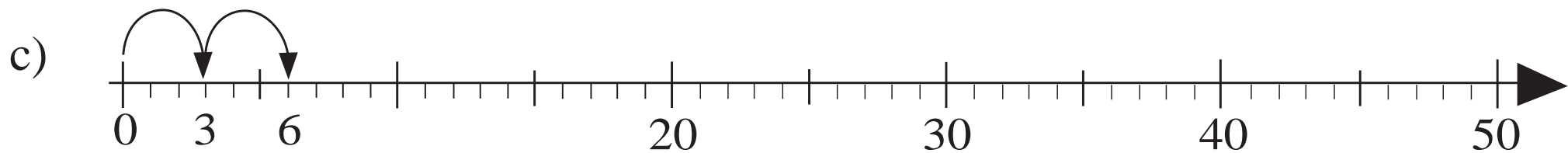
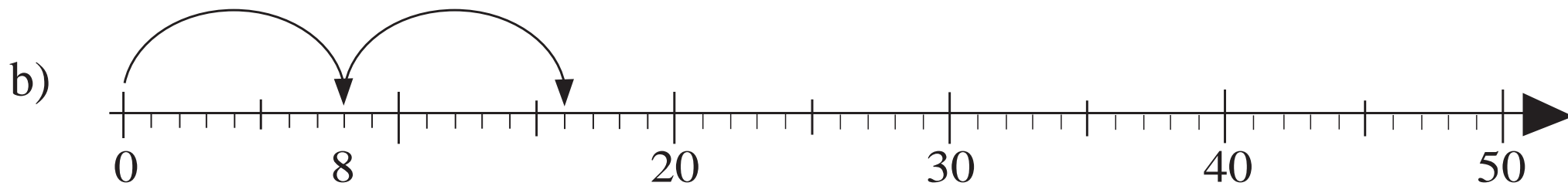
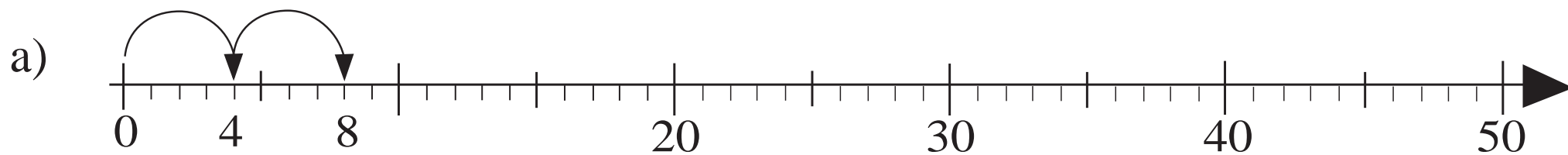



x	0	1	2	3	4	5	6	7	8	9	10
0	0	0	0	0	0	0	0	0	0	0	0
1	0	1	2	3	4	5	6	7	8	9	10
2	0	2	4	6	8	10	12	14	16	18	20
3	0	3	6			15					30
4	0	4	8			20					40
5	0	5	10	15	20	25	30	35	40	45	50
6	0	6	12			30					60
7	0	7	14			35					70
8	0	8	16			40					80
9	0	9	18			45					90
10	0	10	20	30	40	50	60	70	80	90	100

Across

- a* The greatest 1-digit odd number
- b* Take away half of 20 from 6 times 10.
- c* Two less than the smallest 3-digit number.

<i>a</i>		<i>d</i>
	<i>b</i>	
<i>c</i>		

Down

- b* Take away 14 from 8 times 9.
- d* Add 7 times 7 to the smallest 1-digit odd number.

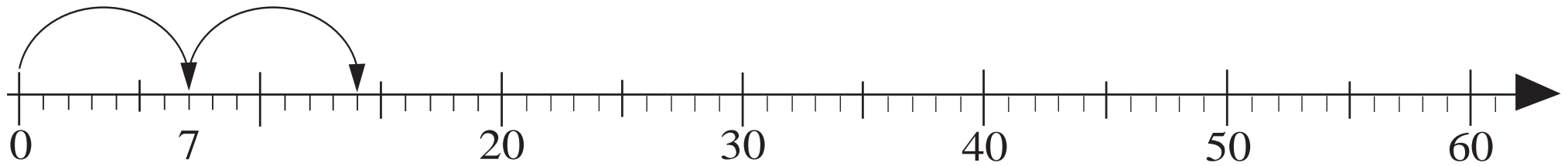

LP 8/4

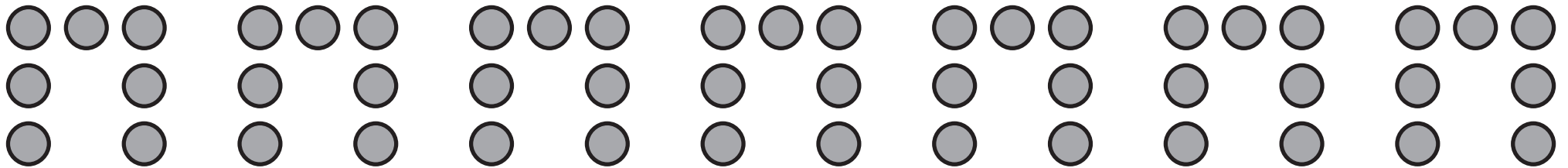

LP 8/5

Number of:



	0	1	2	3	4	5	6	7	8	9	10	11	12	15	20	21
Heads																
Legs																

LP 8/7

a) $\textcircled{1}$ $\textcircled{1}$

b) $\textcircled{1}$ $\textcircled{1}$ $\textcircled{1}$ $\textcircled{1}$

c) $\textcircled{1}$ $\textcircled{1}$ $\textcircled{1}$ $\textcircled{1}$ $\textcircled{1}$ $\textcircled{1}$ $\textcircled{1}$ $\textcircled{1}$



x	0	1	2	3	4	5	6	7	8	9	10
0											
1											
2			4	6	8	10	12		16	18	20
3			6	9	12	15	18		24	27	30
4			8	12	16	20	24		32	36	40
5			10	15	20	25	30		40	45	50
6			12	18	24	30	36		48	54	60
7											
8			16	24	32	40	48		64	72	80
9			18	27	36	45	54		72	81	90
10			20	30	40	50	60		80	90	100

$$18$$

$$3 \times 9$$

$$3 + 15$$

$$40 - 22$$

$$9 + 3 \times 3$$

✂ LP 9/1

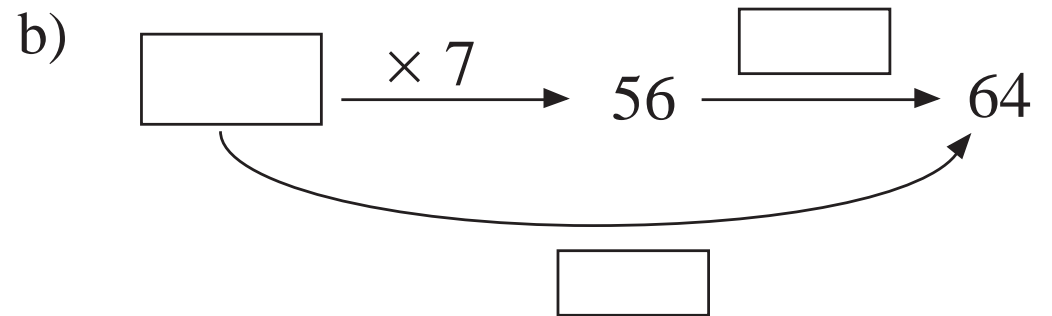
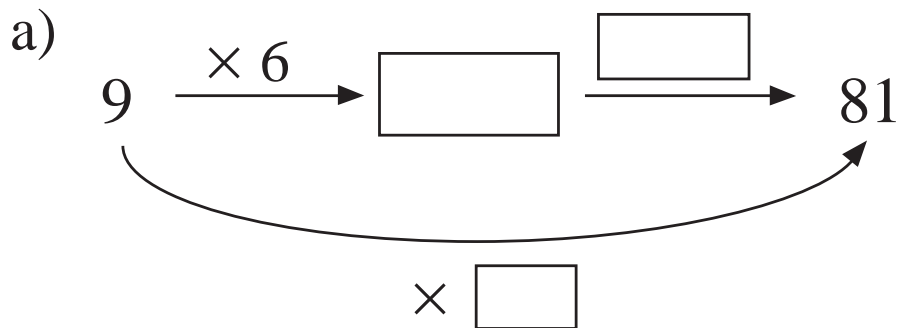

$$3 \times 3 + 3 \times 5$$

$$7 \times 5 + 1$$

$$51 - 3 \times 9$$

$$45 - 21$$

$$8 \times 6 - 12$$

$$4 \times 8 + 4$$

24

36

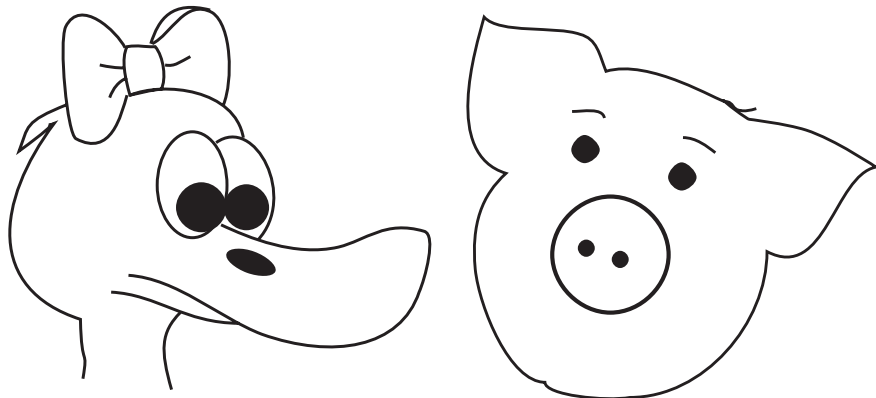

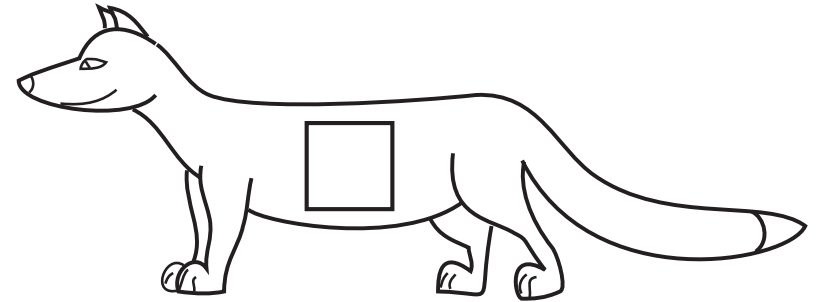
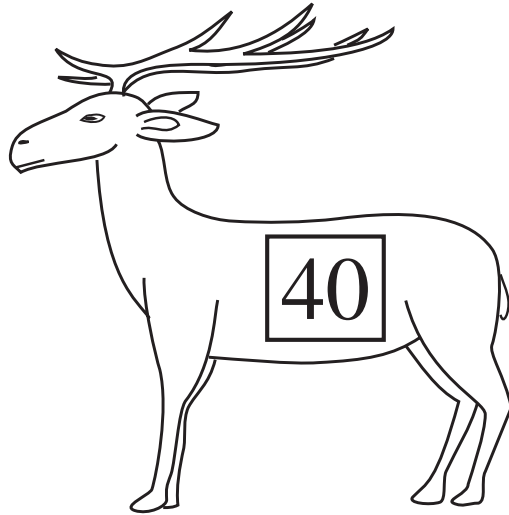
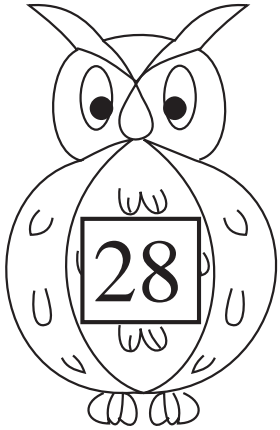

$$8 \times 4$$

$$2 \times 5 + 6 \times 3$$

$$6 \times 3 + 7 \times 2$$

$$9 \times 4 + 4$$

$$7 \times 4$$

$$2 \times 5 + 6 \times 3$$

$$5 \times 9$$

$7 \times 6 - 32$

$100 - 88$

$(50 - 6 \times 4) - 2$

6×4

$81 \div 9 \times 5$

$(3 + 2) \times 5$

$10 \div 2 + 5$

$32 - 22$

$(3 - 1) \times 6$

$71 - 26$

$27 + 18$

$4 \times (7 - 3)$

8×8

$(14 + 18) \times 2$

$40 \div 2 - 4$

4×16

$10 \times 9 - 26$

	23	
25	27	
	31	24

a)

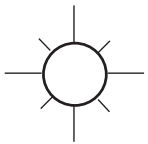
	6	7	4			5		0	8
	18	21		27	30		3		6

$$\text{star} =$$

$$\text{sun} =$$

b)

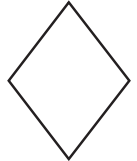
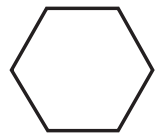
	6	2	7	9			10	8	12
	19	3	23	31	39	15			7

$$\text{diamond} =$$

$$\text{hexagon} =$$

1 1 1 1 1 1 1 1 1 1

1 1 1 1 1 1 1 1 1 1

1 1 1 1 1 1 1 1 1 1

1 1 1 1 1 1 1 1 1 1

1 1 1 1 1 1 1 1 1 1

1 1 1 1 1 1 1 1 1 1



a)

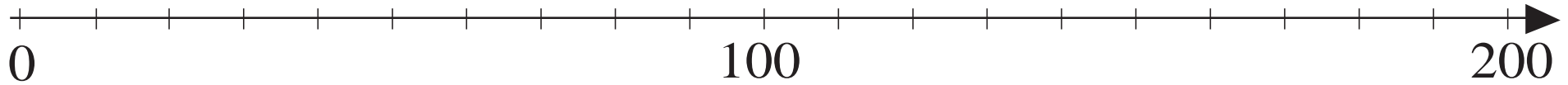
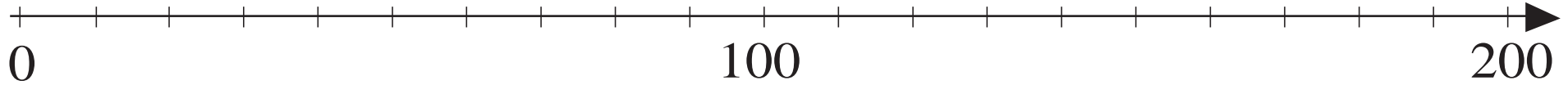
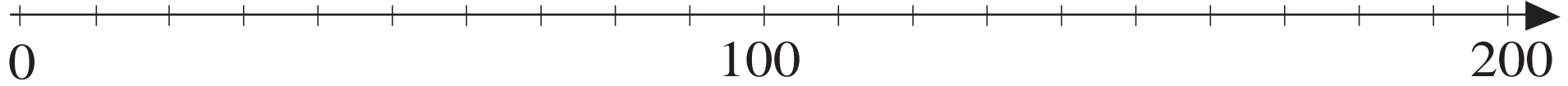

b)

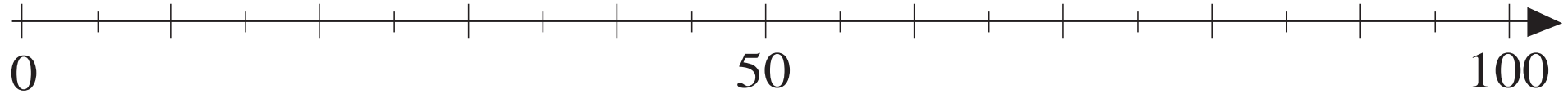
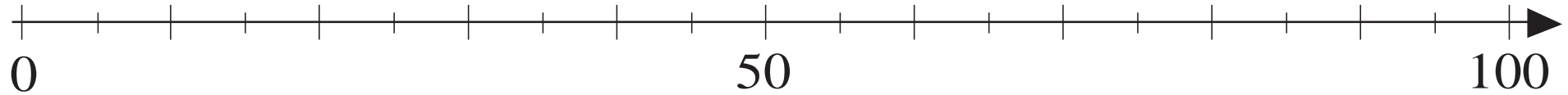

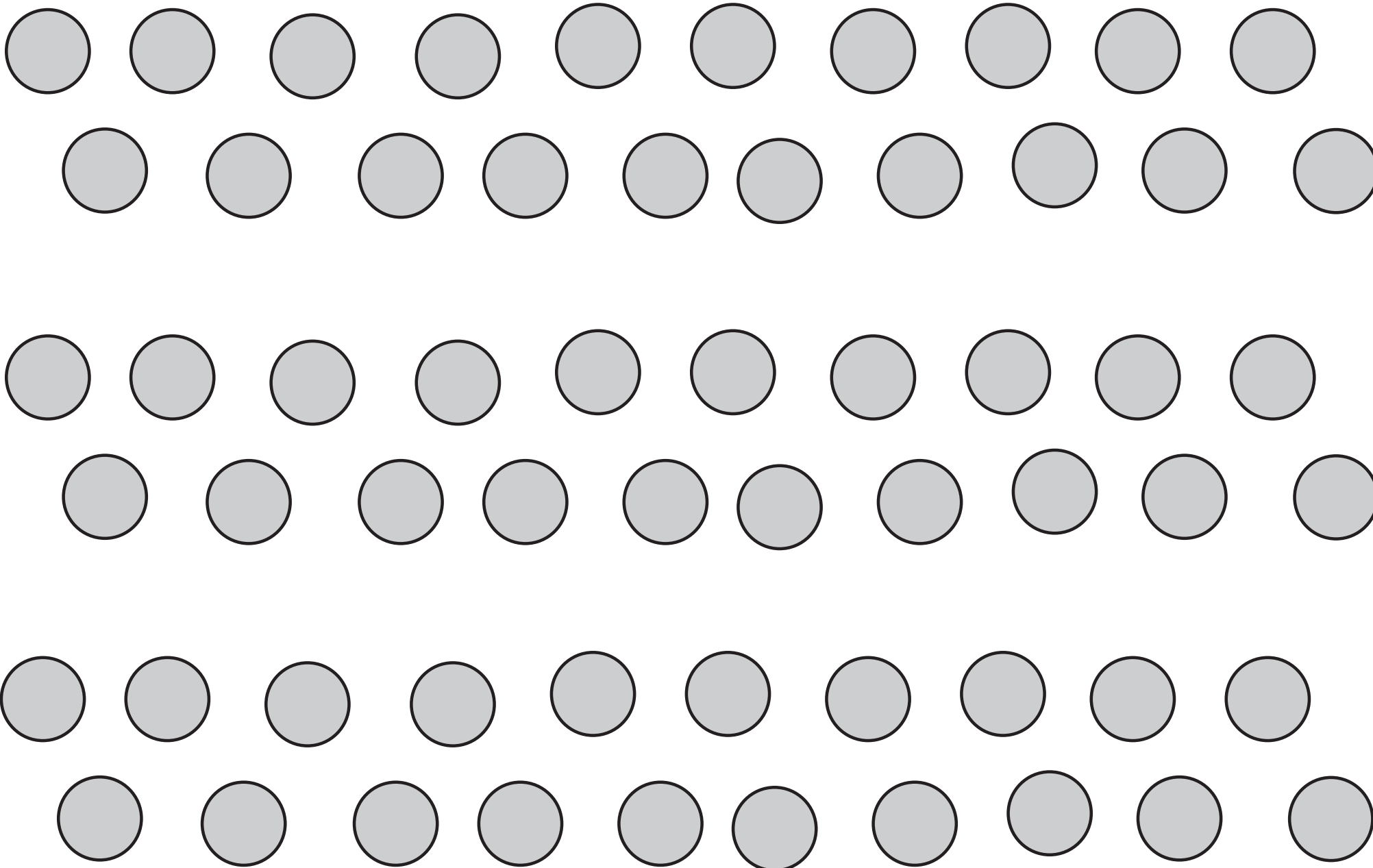

a)

■	■	□	□
■	■	□	□
□	□	■	■
□	□	■	■

b)

■	□	■	□	□
□	■	□	□	□
■	□	■	□	□
□	□	□	□	□
□	□	□	□	□

c)

■	□
□	■
□	□
□	□
□	□

d)

■	□
□	■
■	□
□	■
■	□

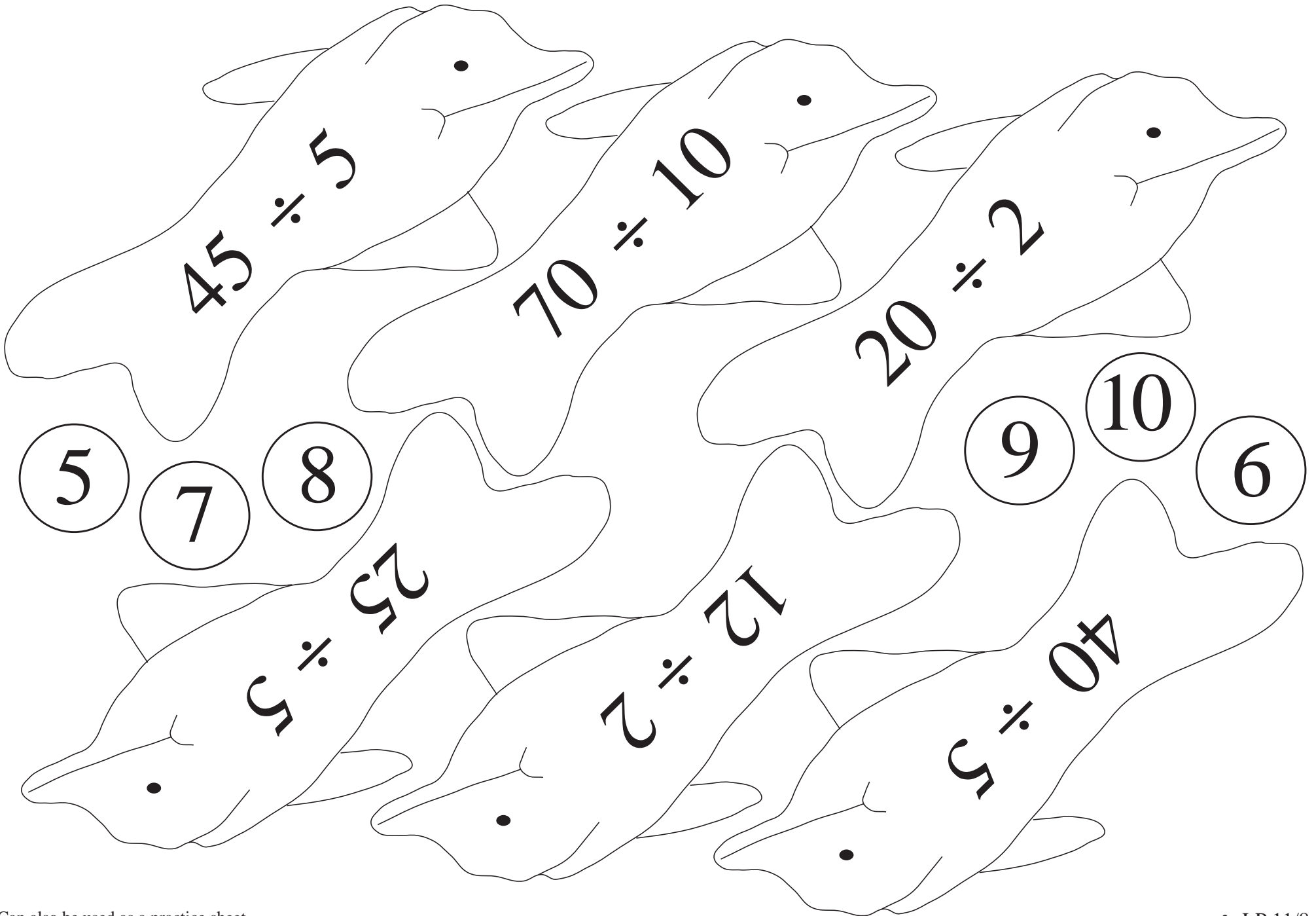

Can also be used as a practice sheet

a)

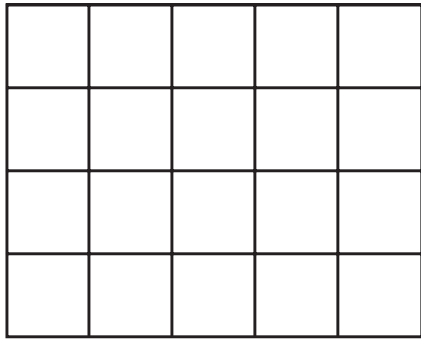

1 half

b)

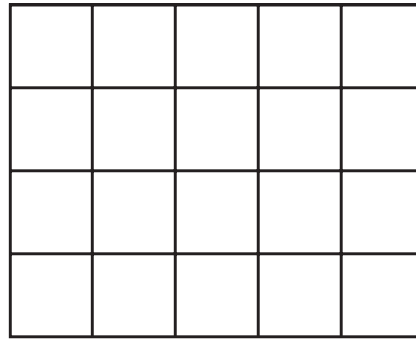

1 fifth

c)

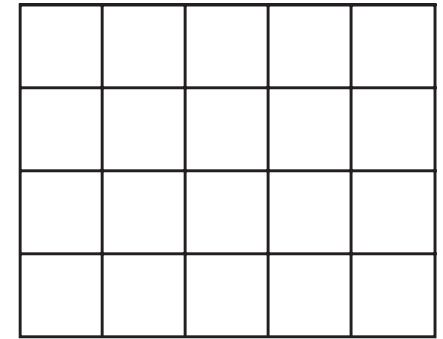

1 tenth

LP 11/9

Number of:

Legs	0	2	4	6	8	12	16	24	32	40	48	56	64	72	80
People	0	1	2	3	4										
Chairs	0	–	1	–	2										
Spiders	0	–	–	–	1										

LP 12/7

a)



..... *Check:*

b)

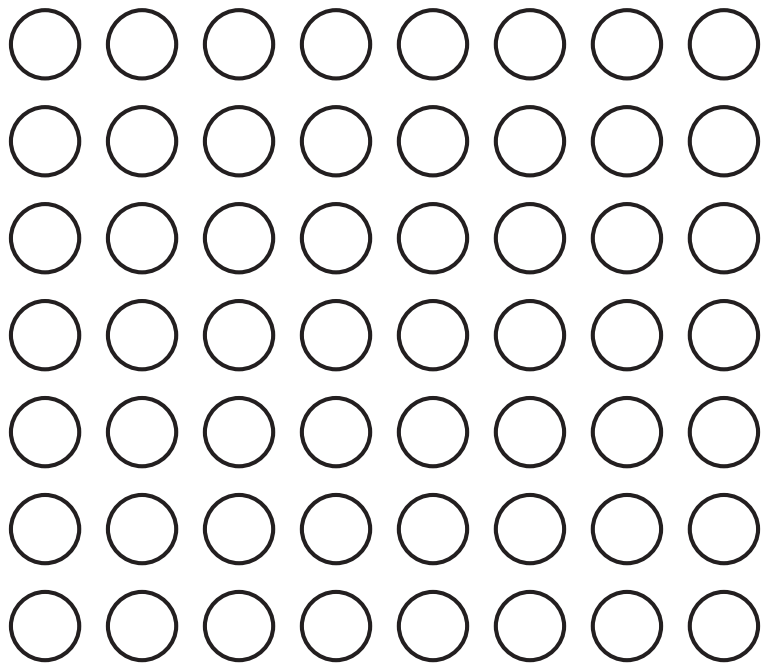

.....

Check:

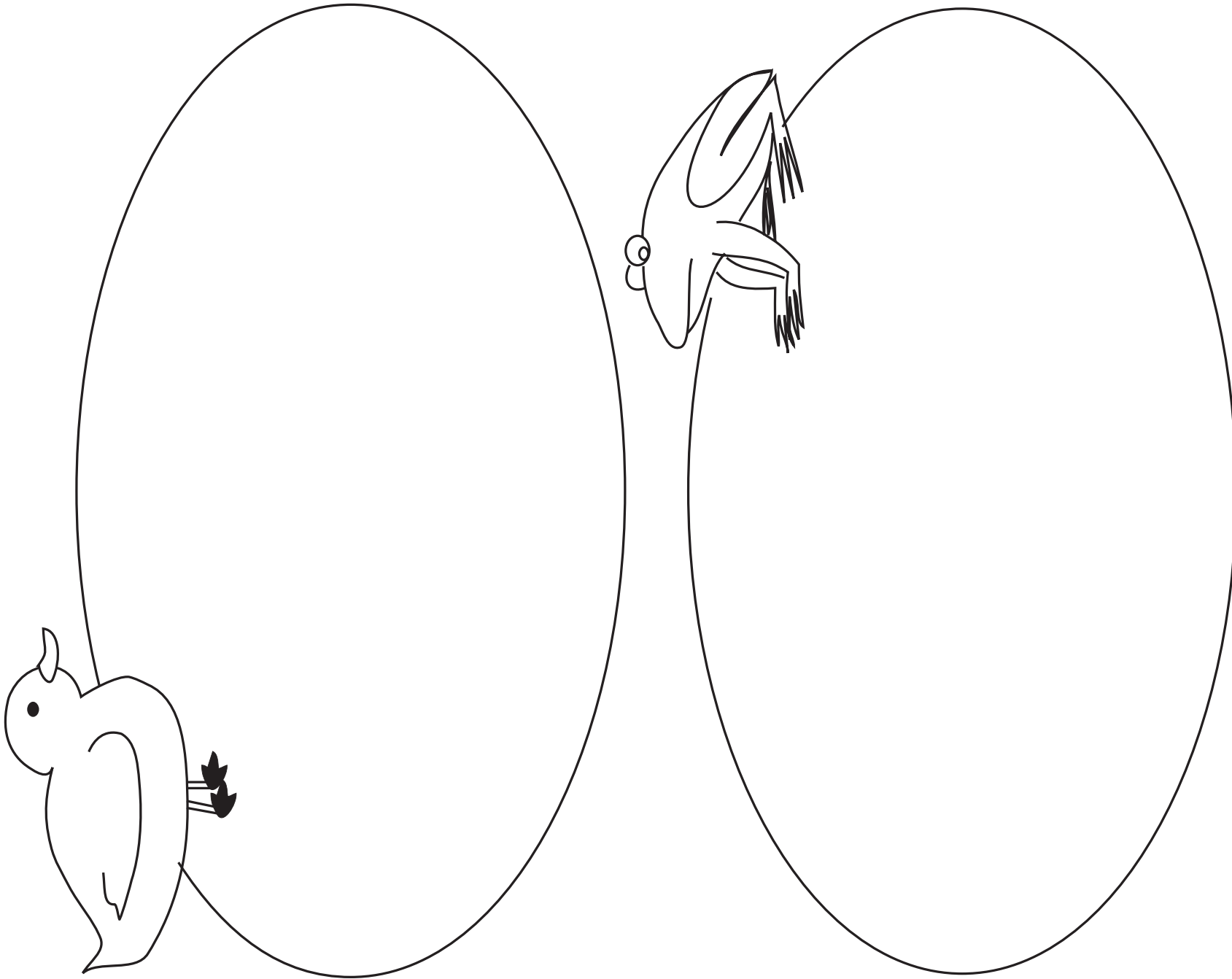

20

15

35

12

16

40

a) $60 \div 10$ $20 \div 2$

b) $18 \div 2$ $36 \div 4$

c) $35 \div 5$ $18 \div 2$

d) $64 \div 8$ $32 \div 4$

e) $10 \div 2$ $10 \div 10$

a)

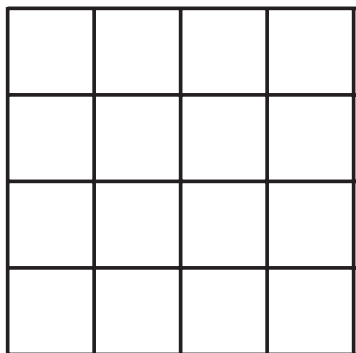

1 half

b)

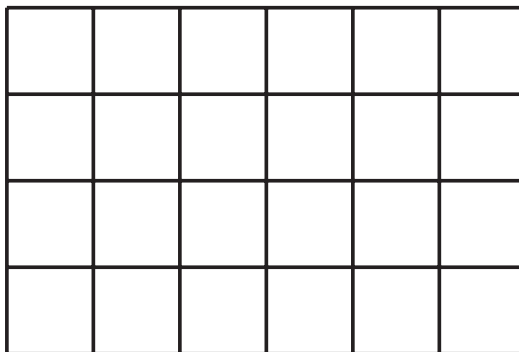

1 eighth

c)

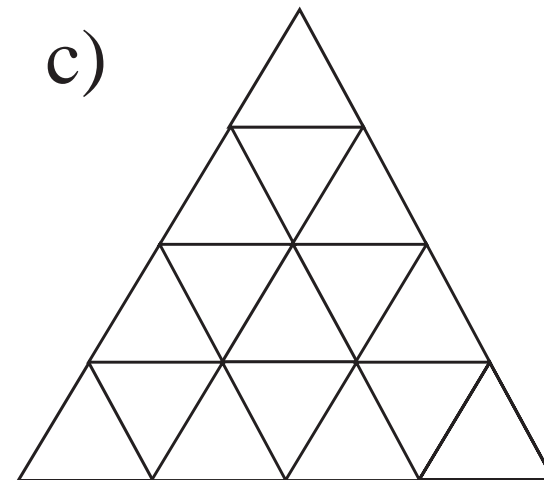

1 quarter



a)

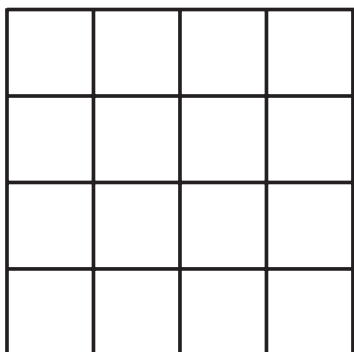

1 half

b)

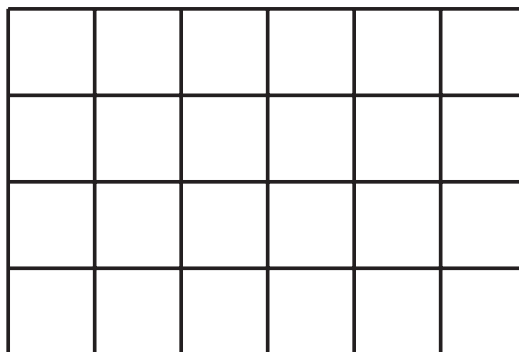

1 eighth

c)

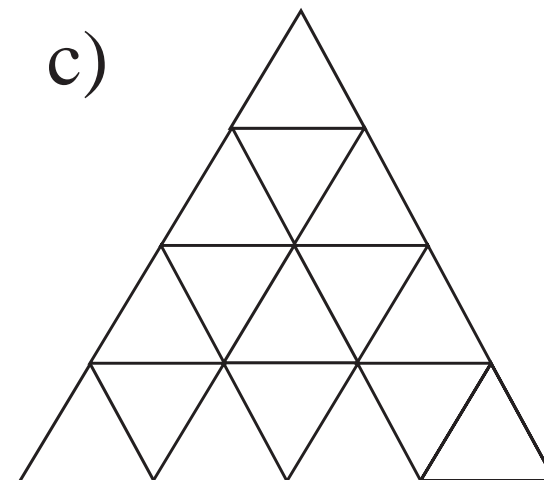

1 quarter

a)

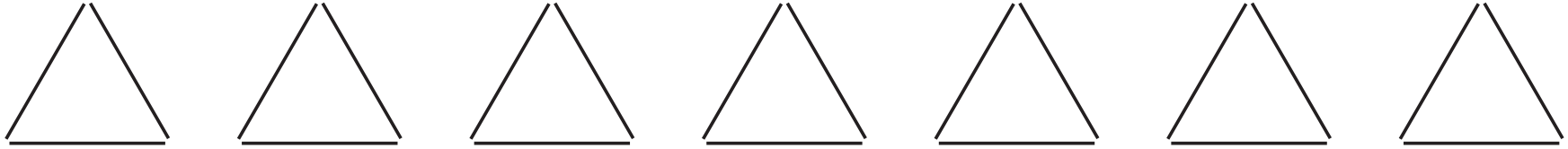

..... *Check:*

b)

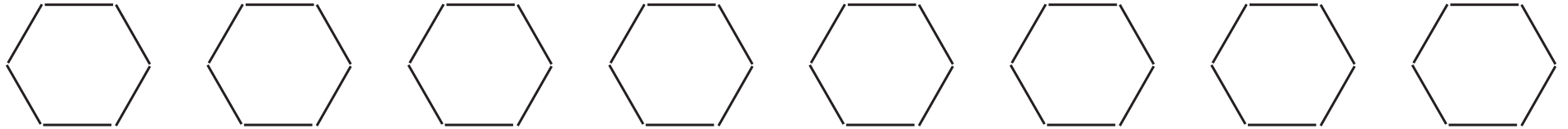

..... *Check:*

c)



..... *Check:*

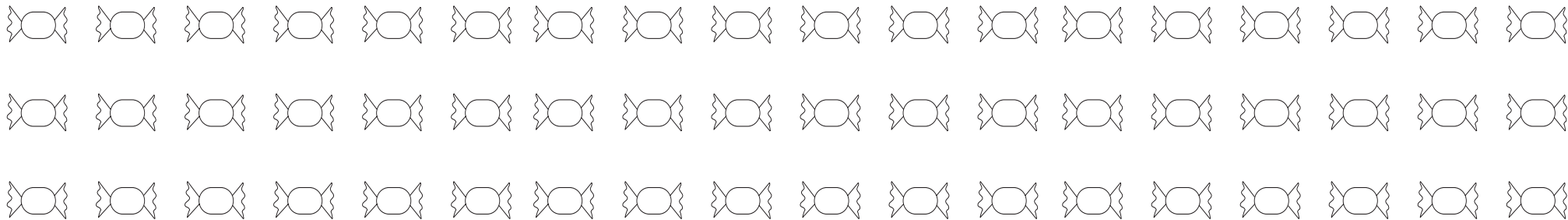

LP 13/5

Number of:

Sticks	0	1	2	3	6	8	9	12	15	18	21	24	27	30	33	36	54	90
	0	-	-	1		-												
	0	-	-	-		-	-											
	0	-	-	-	-	-												

LP 13/8

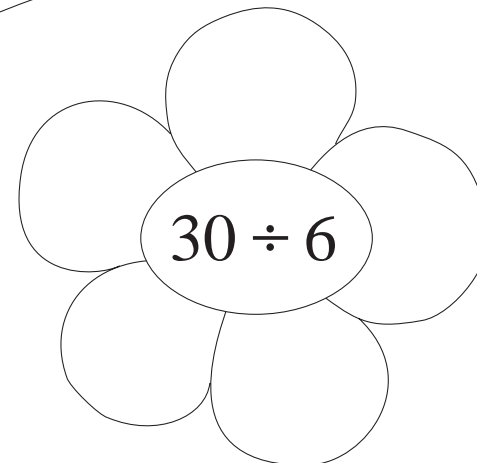
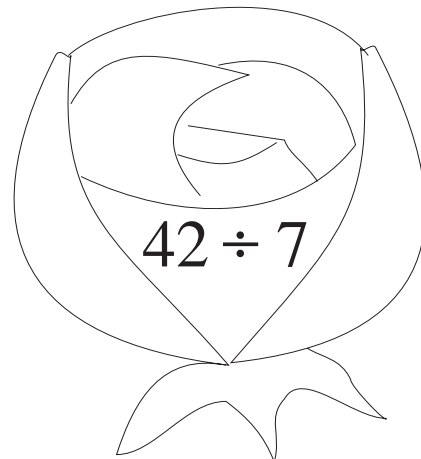
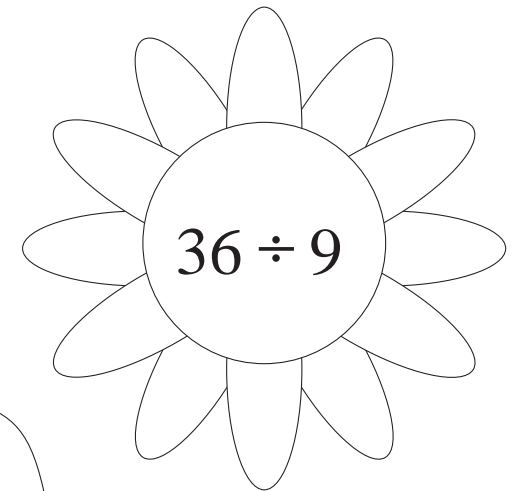
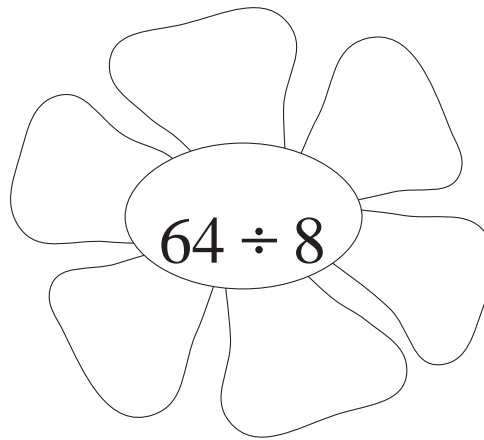
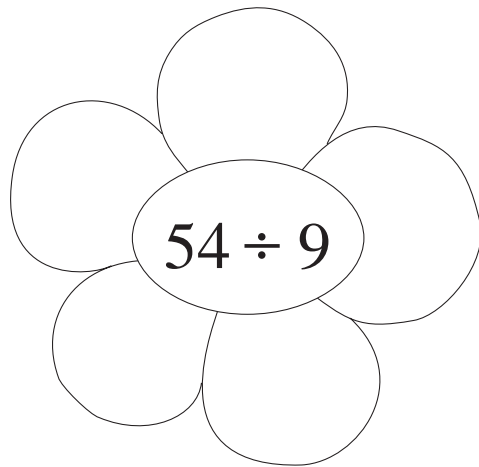
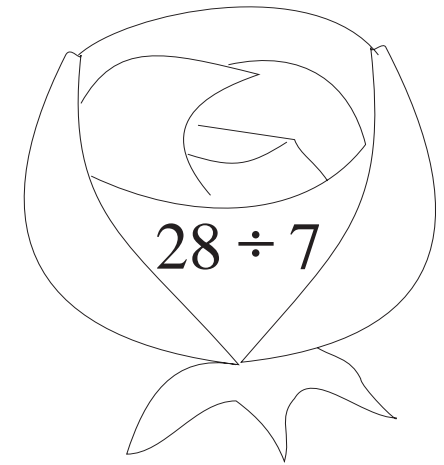
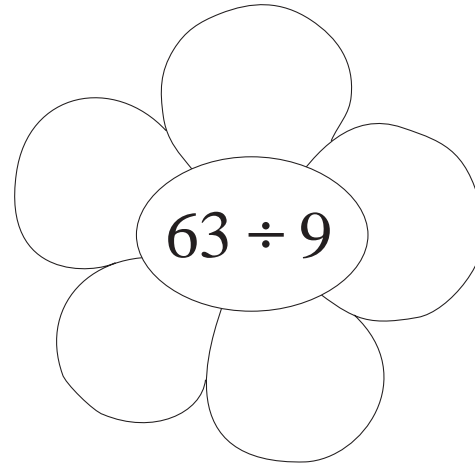
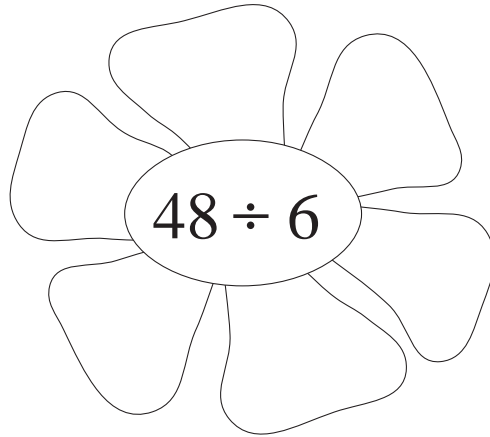
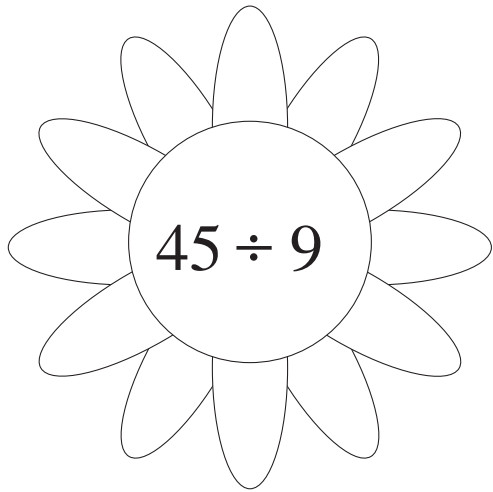

Days	0	1	3	6	7	10	14	21	25	28		42			63	70	84
Weeks	0	-	-	-	1	-					5		7	8			

LP 14/3

a)

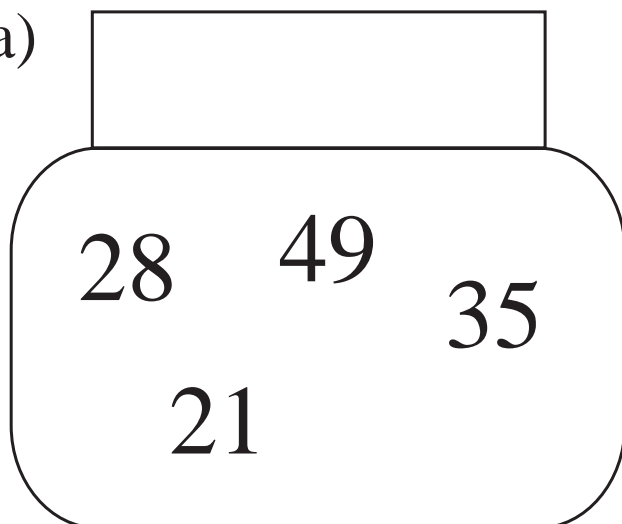

b)

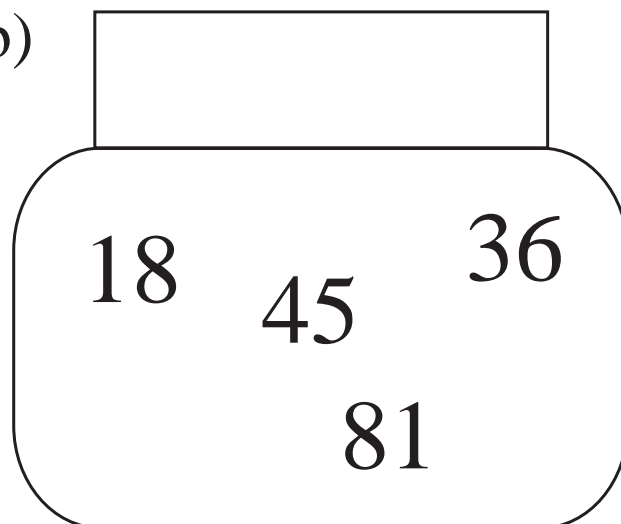

c)

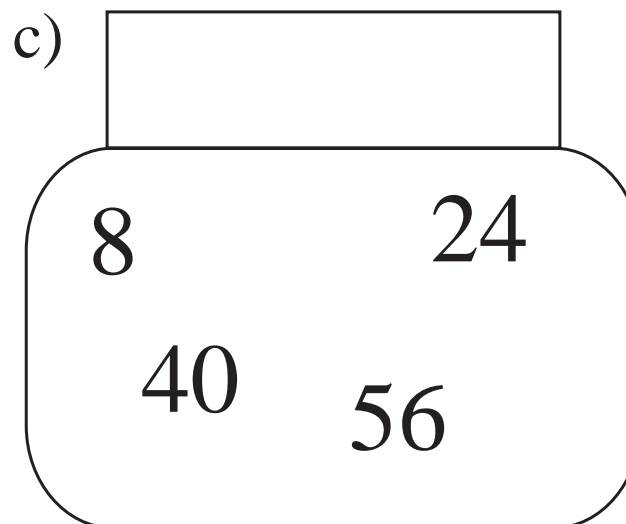

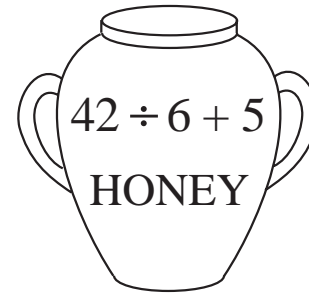
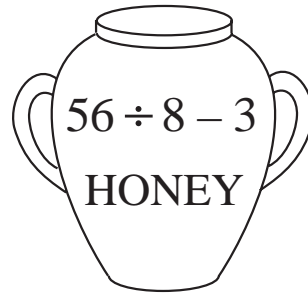

LP 14/6

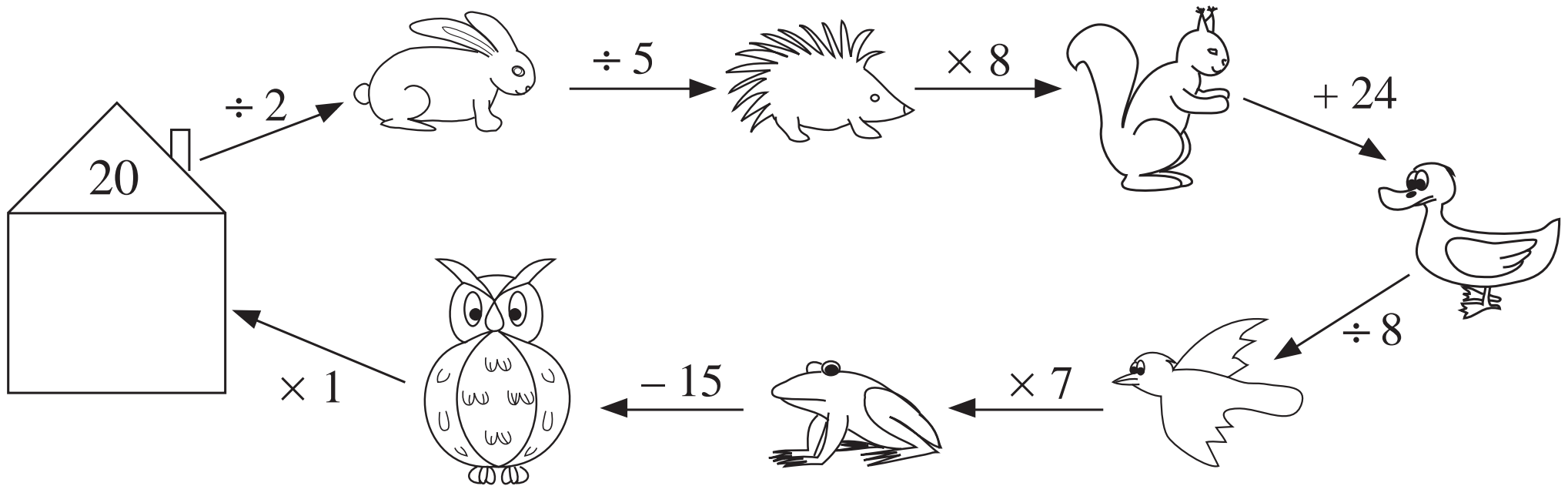

a) $42 \div 7 = 54 \div \square$

b) $18 \div 9 = 16 \div \triangle$

c) $\triangle \div 8 = 21 \div 7$

d) $\square \div 7 = 81 \div 9$

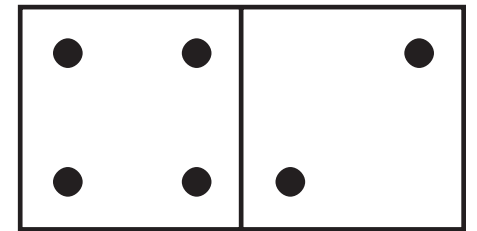
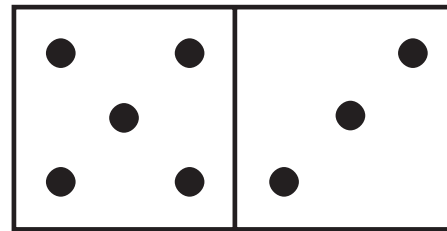
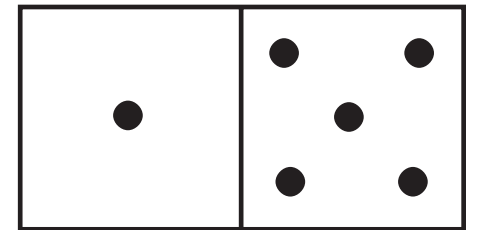
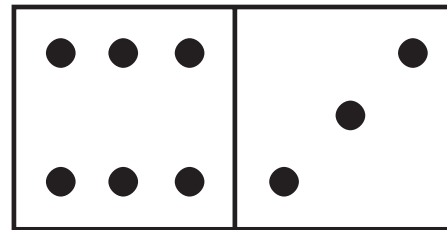
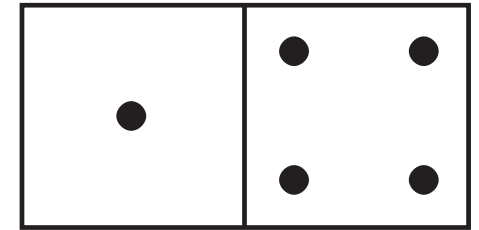
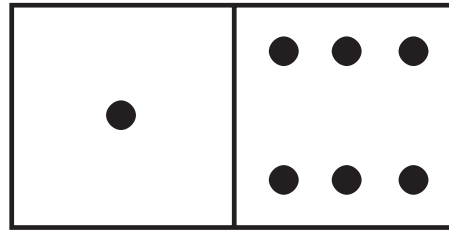
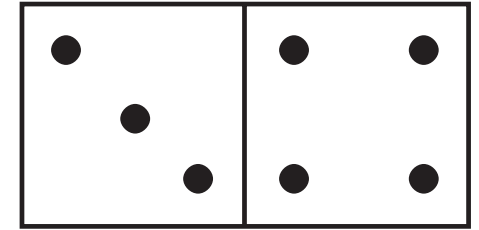
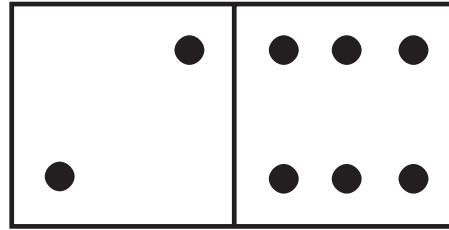

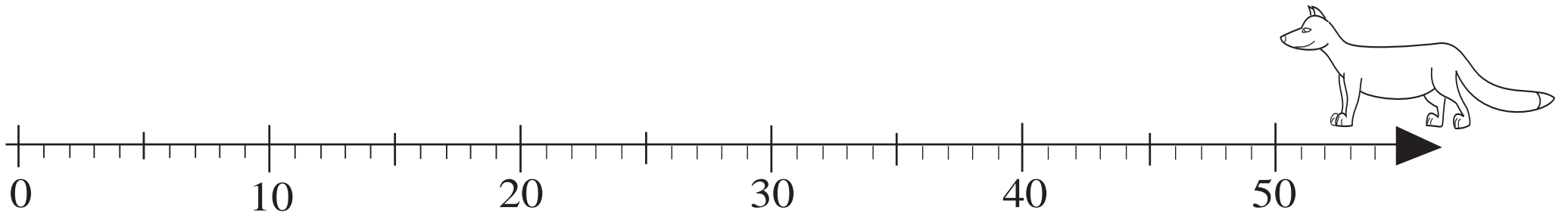

LP 16/1

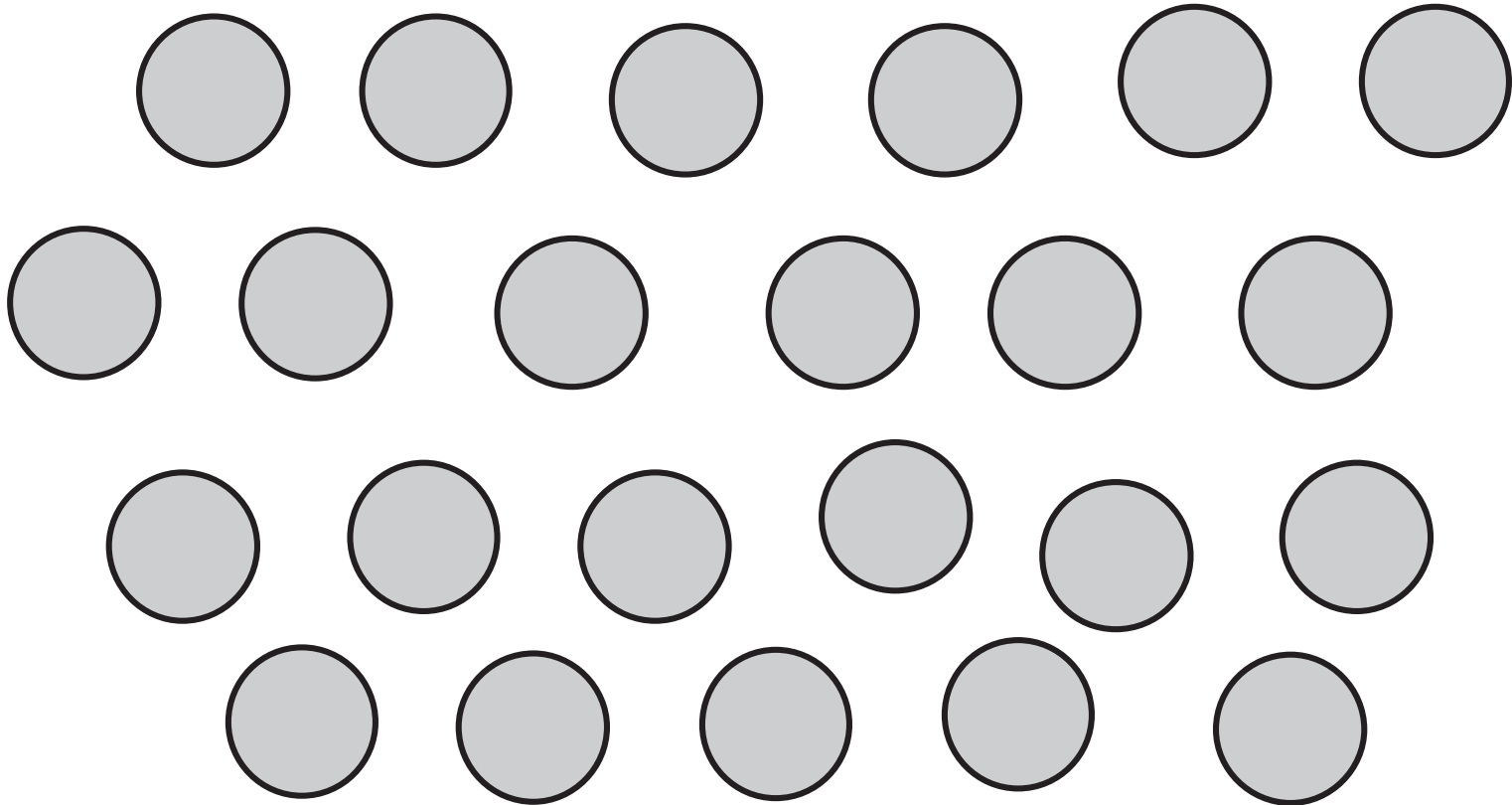

LP 16/2

$$\text{a) } 3 \times 9 - 2 < 3 \times (9 - 2)$$

$$\text{b) } 4 \times 5 + 12 > 4 \times (5 + 12)$$

$$\text{c) } 32 \div 8 + 8 > 32 \div (8 + 8)$$

$$\text{d) } 5 + 5 \times 5 < (5 + 5) \times 5$$

$$\text{e) } 7 + 4 \times 3 < (7 + 4) \times 3$$

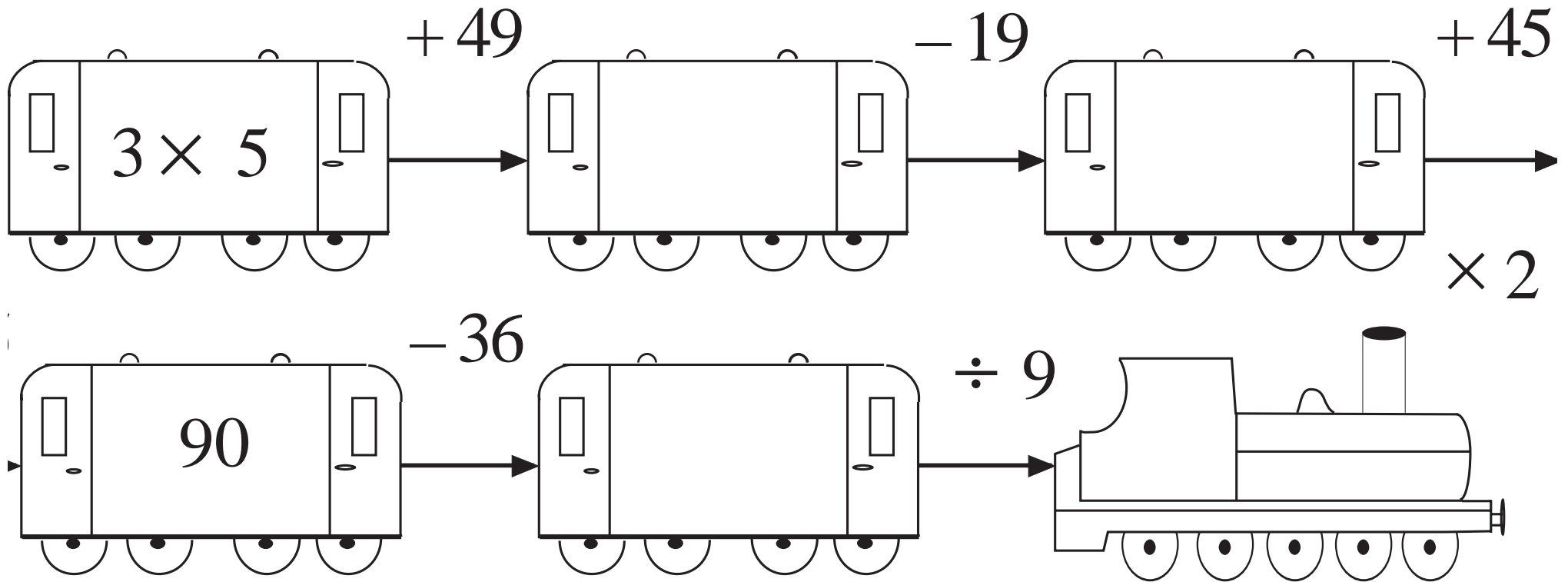

✂ LP 17/1

Number of:

Ⓛ1	10	16	24	43				61	77	99	100
Ⓛ5	2				3	7	10				
Ⓛ1 remaining	0				3	0	2				

LP 17/8

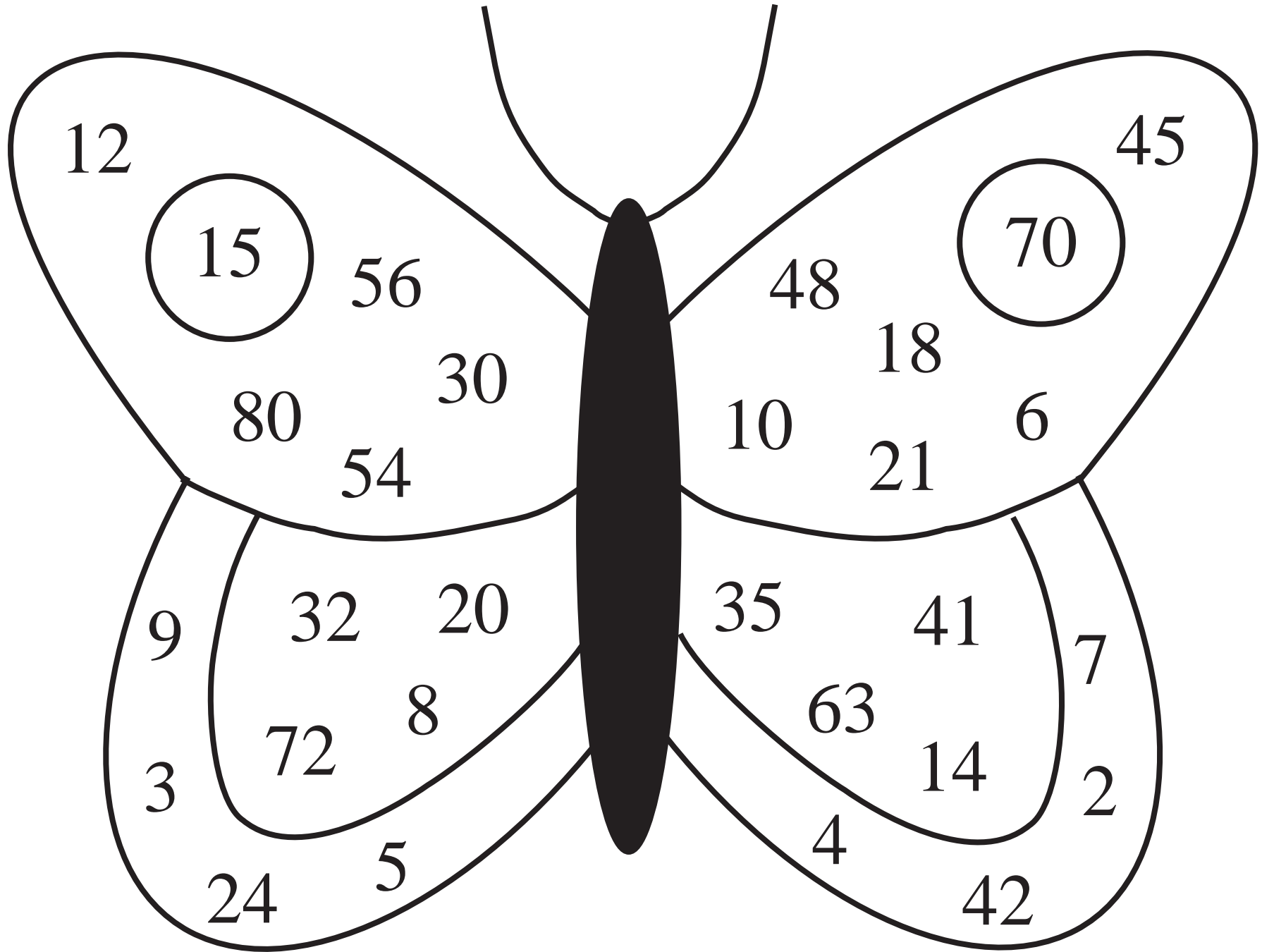

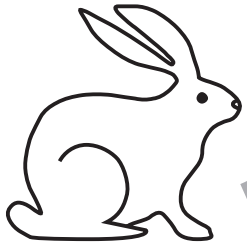

$$8 \times 7 = 56$$

$$8 \times 4 = 32$$



$$70 - 14 = 56$$

$$32 + 19 = 51$$

$$32 \div 5 = 6, r 2$$

$$9 + 6 \times 5 = 39$$

$$70 - 9 = 61$$

$$9 \times 7 = 56$$

$$9 + 4 \times 5 = 29$$

$$12 \times 2 + 15 = 39$$



a) $14 \div 3 = \square$
remainder \square
Check

$19 \div 2 = \square$
remainder \square
Check

$17 \div 6 = \square$
remainder \square
Check

b) $28 \div 9 = \square$
remainder \square
Check

$33 \div 5 = \square$
remainder \square
Check

$24 \div 6 = \square$
remainder \square
Check

c) $47 \div 5 = \square$
remainder \square
Check

$54 \div 6 = \square$
remainder \square
Check

$38 \div 9 = \square$
remainder \square
Check

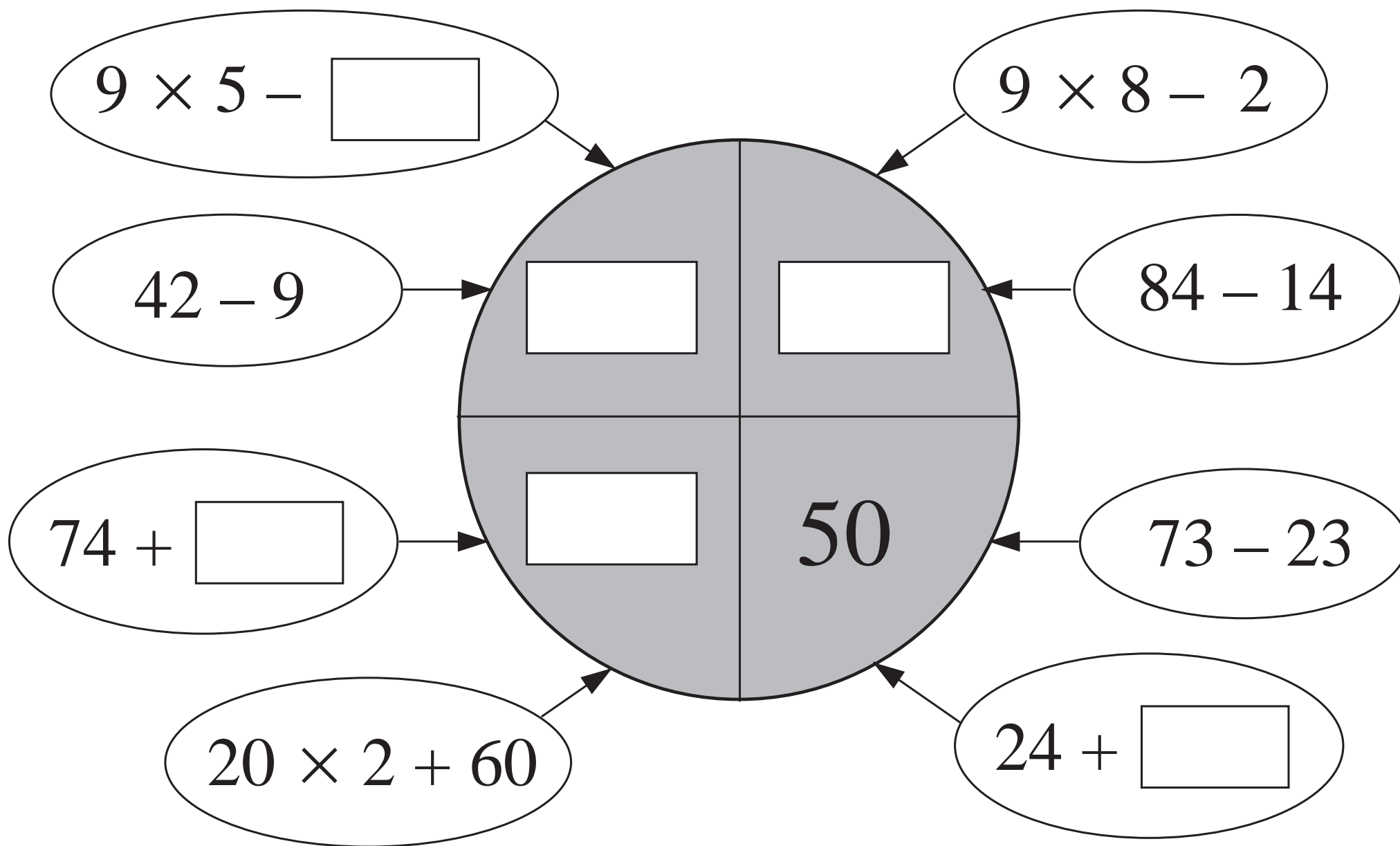

a)

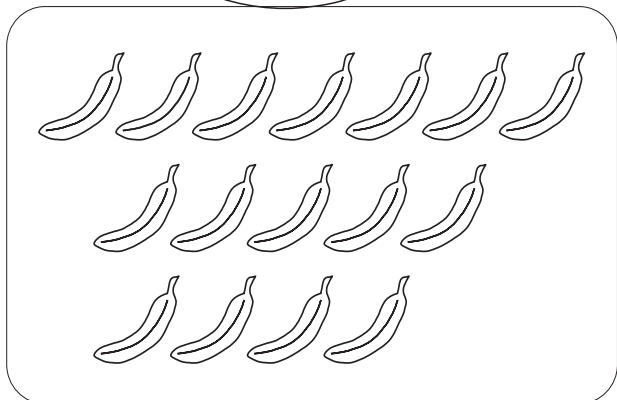
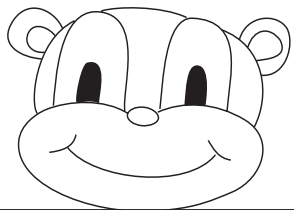

b)

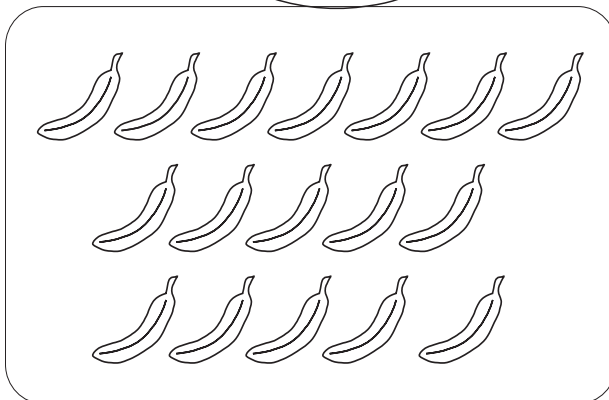
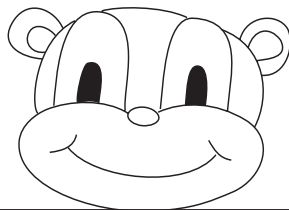

c)

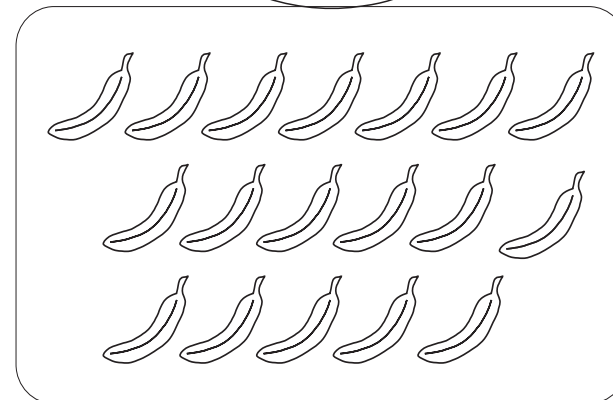

d)

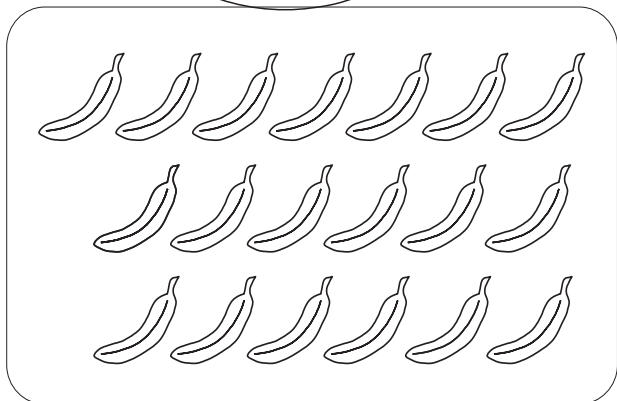
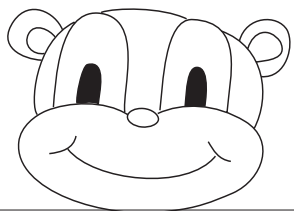

e)

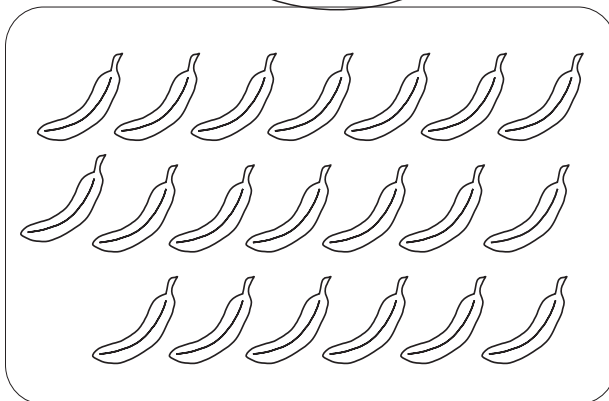

f)

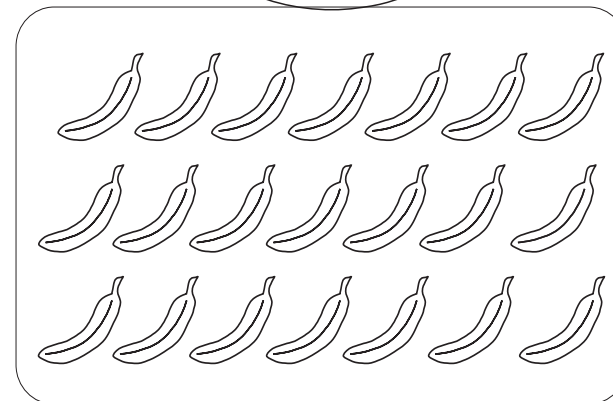

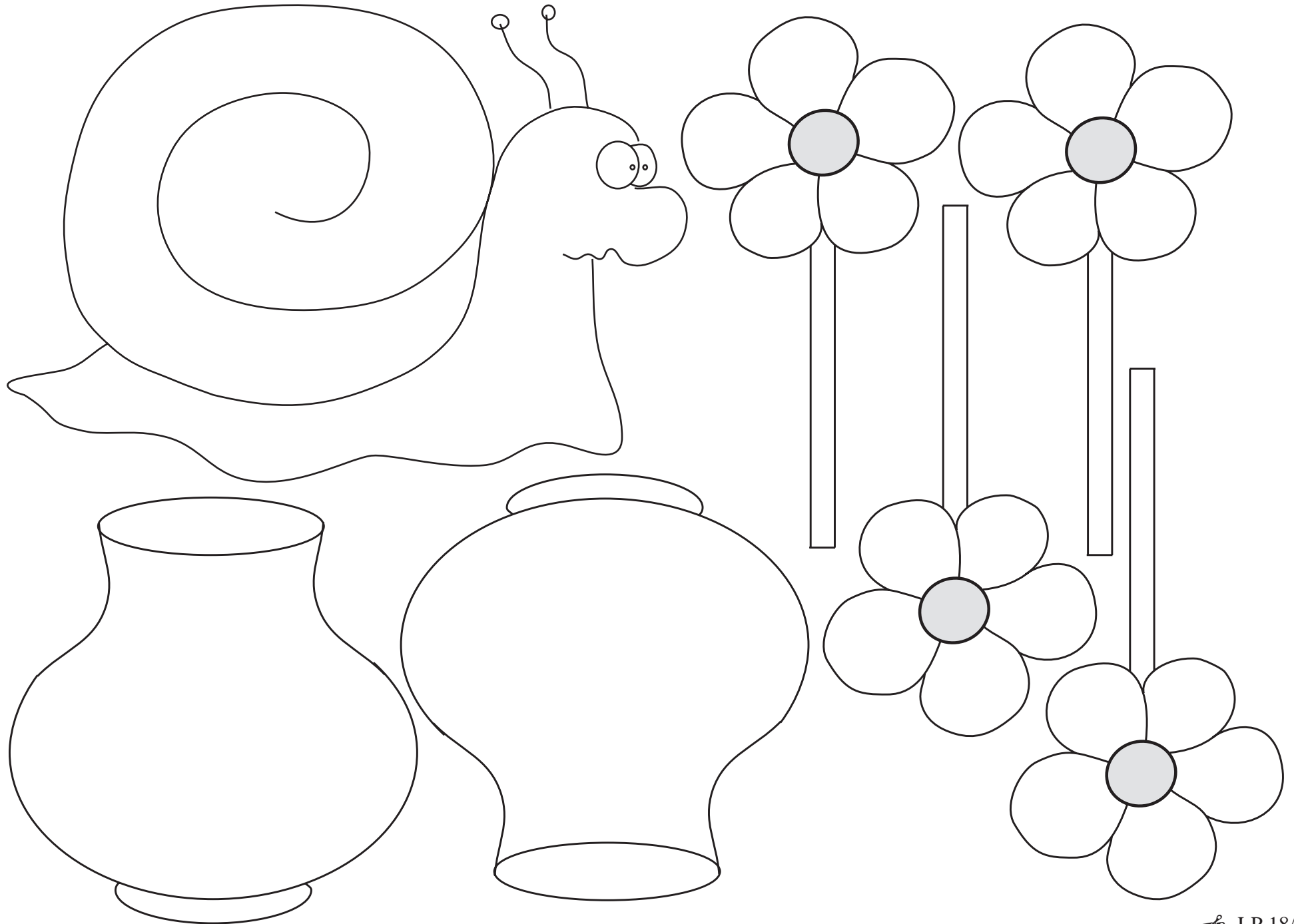

Days in January

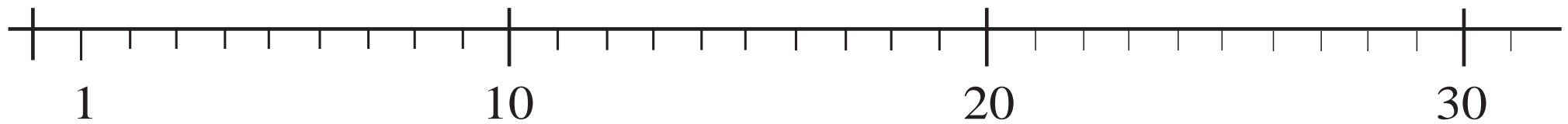

LP 18/5

$$\text{a) } (2 + 8) \times 7 = \quad =$$

$$\text{b) } (11 - 3) \times 9 = \quad =$$

$$\text{c) } (21 + 14) \div 7 = \quad =$$

$$\text{d) } (24 - 8) \div 4 = \quad =$$

$$\text{e) } 80 \div (12 - 4) = \quad =$$

$$\text{f) } 72 \div (3 + 6) = \quad =$$

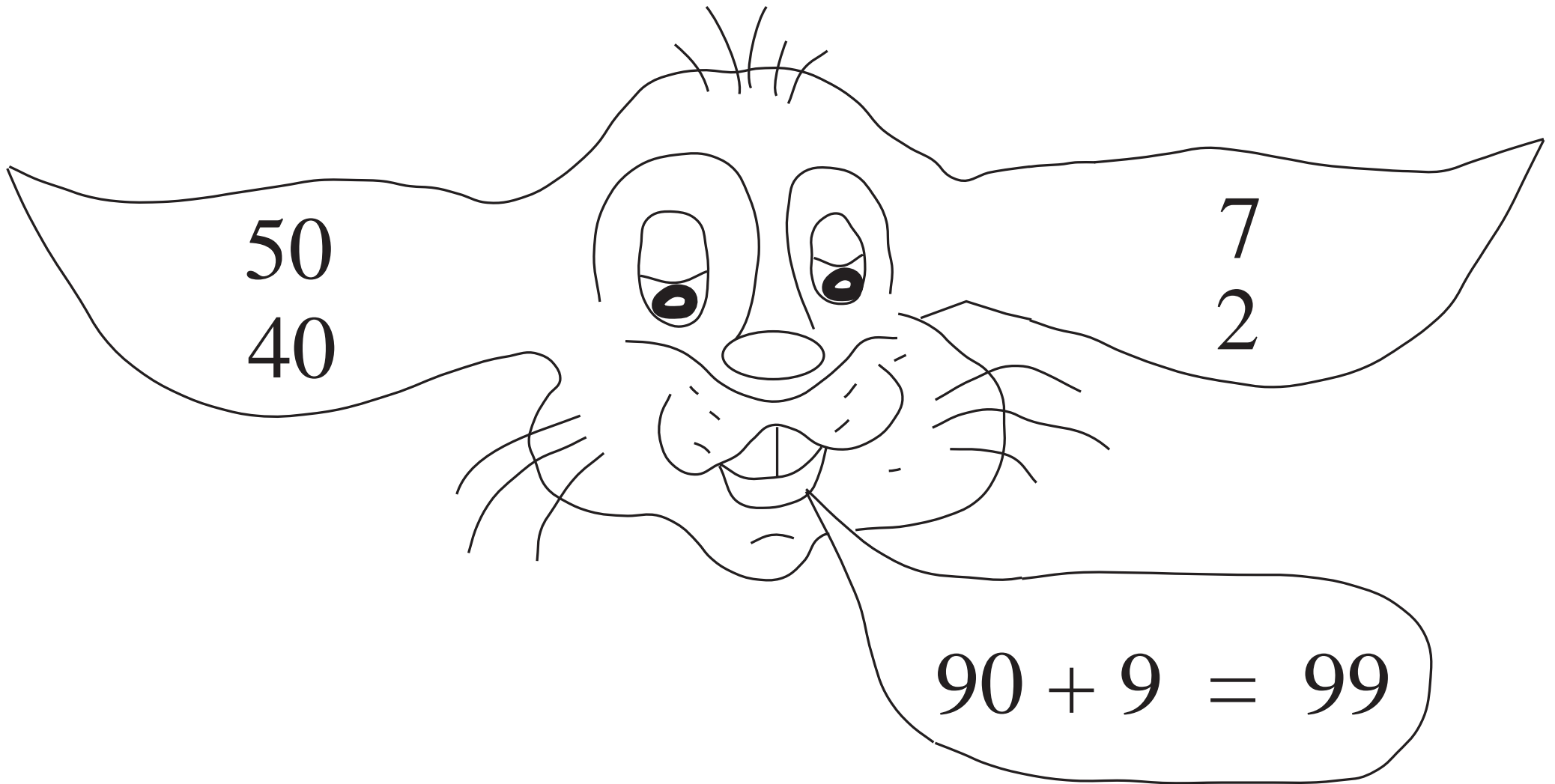

Right ear	50	20	12	24	9	19	8
	40	9	17	17	7	45	24
Left ear	7	12	15	32	12	3	4
	2	8	9	9	19	7	17
Total	99						

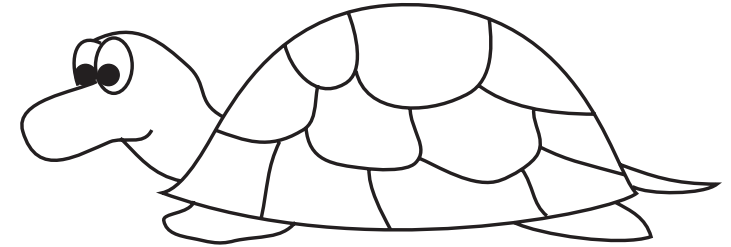
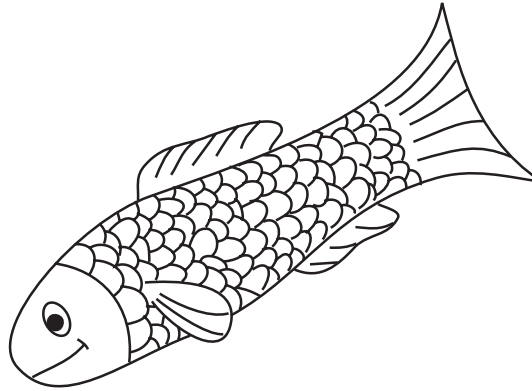
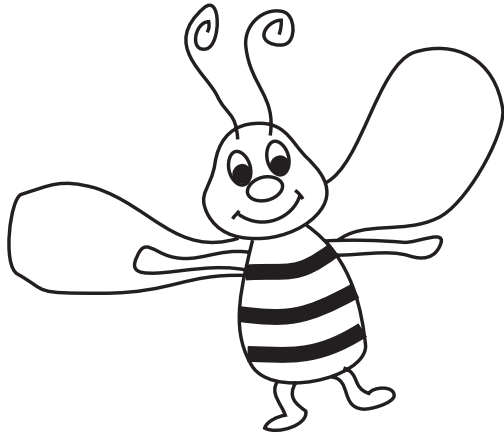

$$\square < 40$$

$$\square = 17$$

$$\square > 50$$

$$\text{a) } 60 \div 6 + 4 \times 2 - 2 =$$

$$\text{b) } 60 \div 6 + 4 \times (2 - 2) =$$

$$\text{c) } 60 \div (6 + 4) \times 2 - 2 =$$

$$\text{d) } (60 \div 6 + 4) \times 2 - 2 =$$

$$\text{e) } 60 \div (6 + 4 \times 2 - 2) =$$

$$\text{f) } 60 \div (6 + 4) \times (2 - 2) =$$

	\times		\div		$= 4$
\times		\div		\times	
	\times		\times		$= 18$
\times		\times		\div	
	\times		\div		$= 6$
$= 27$		$= 16$		$= 9$	

Motorway			Your height		
Rubber			Pin head		
Book			Length of the classroom		
mm	cm	m	cm	m	km

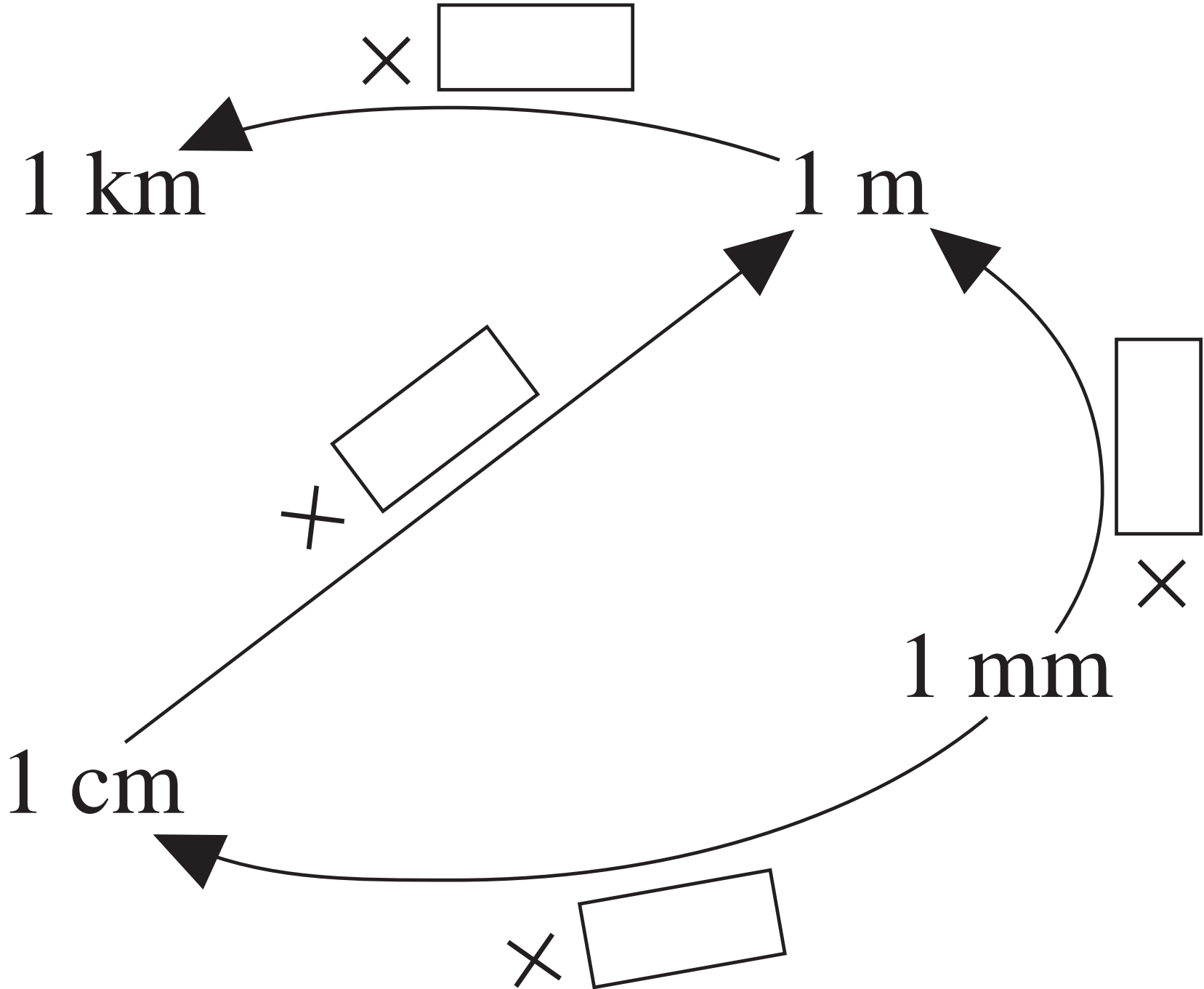

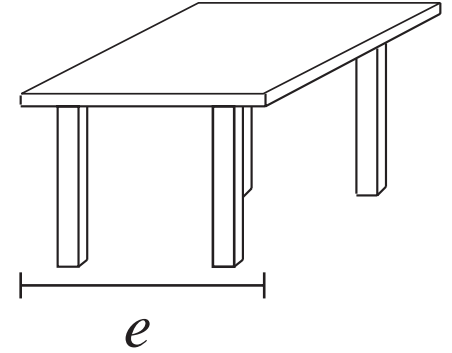
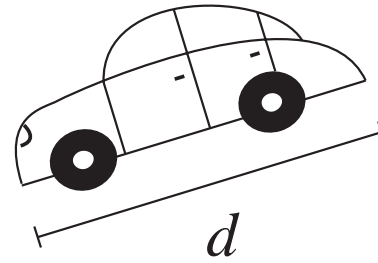
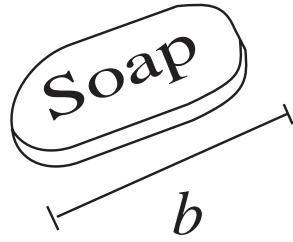
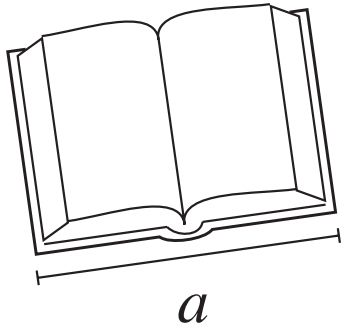

$$1 \text{ m} < \square < 2 \text{ m}$$

$$8 \text{ cm} < \square < 10 \text{ cm}$$

$$20 \text{ cm} < \square < 30 \text{ cm}$$

$$4 \text{ m} < \square < 5 \text{ m}$$

$$10 \text{ m} < \square < 20 \text{ m}$$

$a \approx$ <input type="text"/>	$b \approx$ <input type="text"/>	$c \approx$ <input type="text"/>	$d \approx$ <input type="text"/>	$e \approx$ <input type="text"/>
$a =$ <input type="text"/>	$b =$ <input type="text"/>	$c =$ <input type="text"/>	$d =$ <input type="text"/>	$e =$ <input type="text"/>

LP 21/6

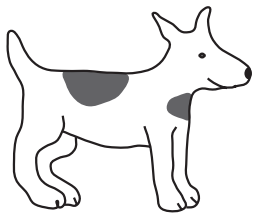

25 g



16 kg



700 g



1 kg

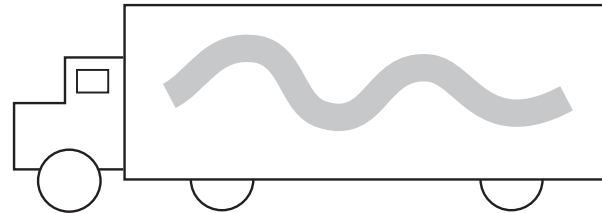

1 tonne



60 kg

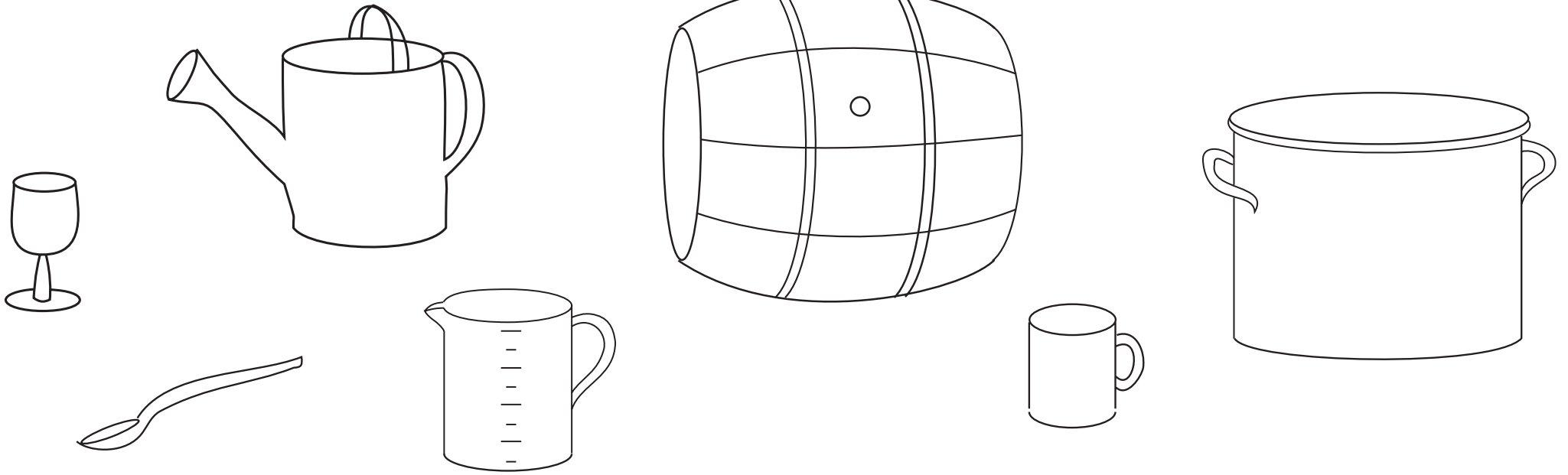

ml

cl

litre

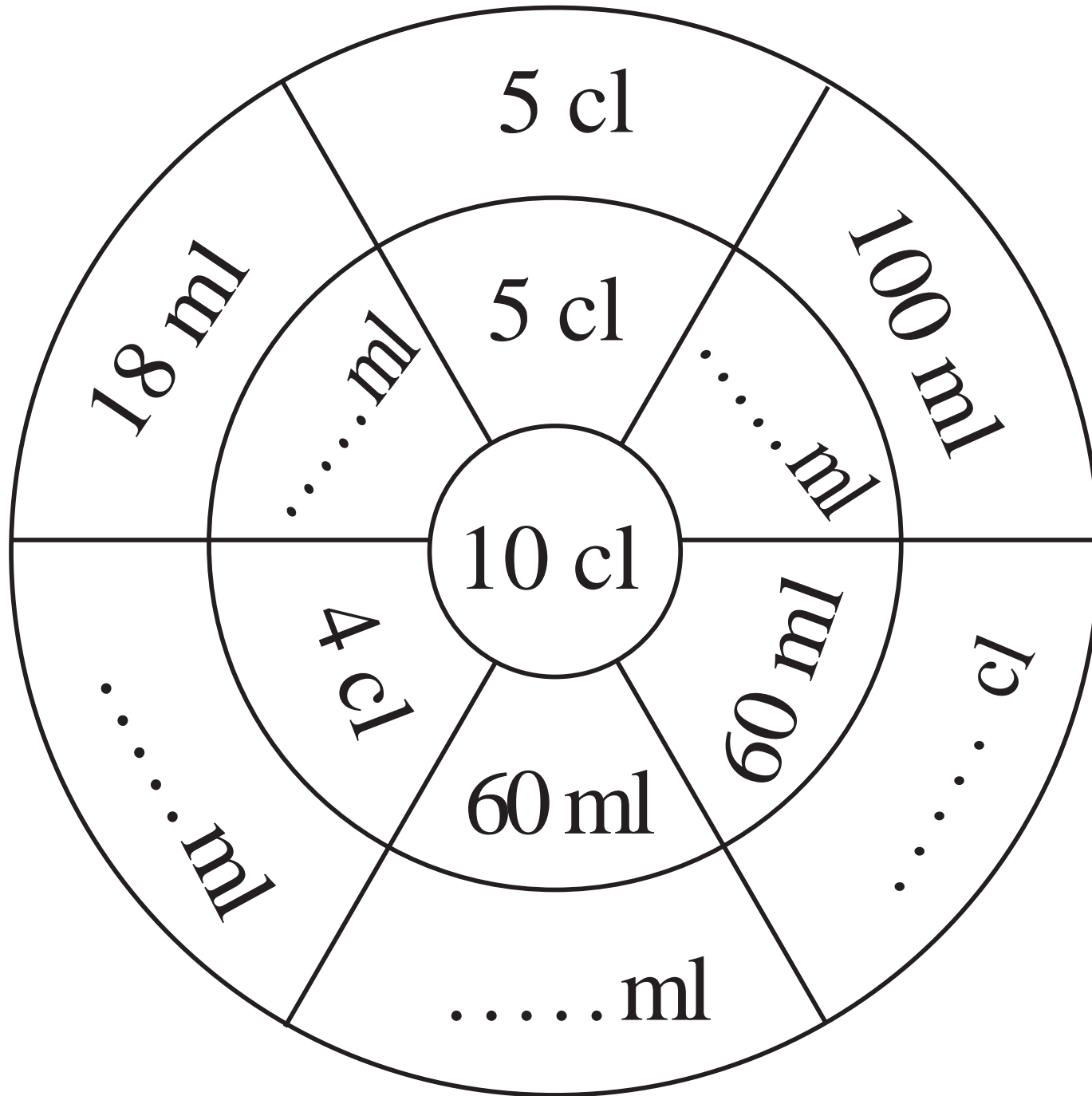

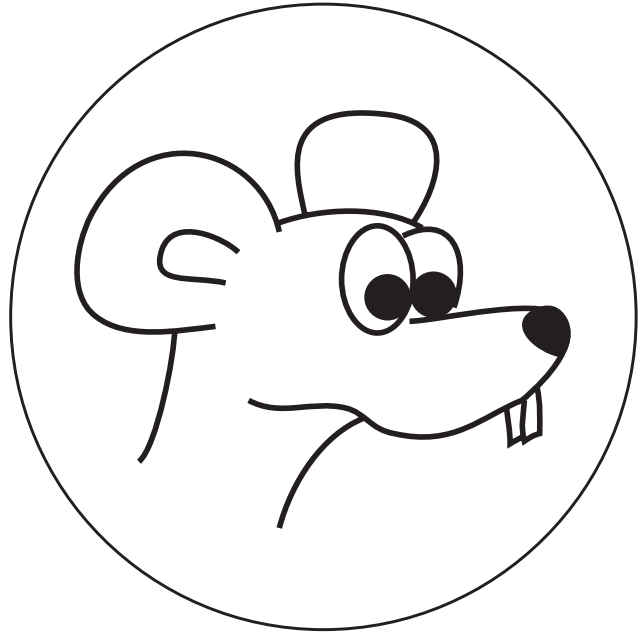

100 cl

10 ml

1 litre

10 cl

1 cl

100 ml

1000 ml

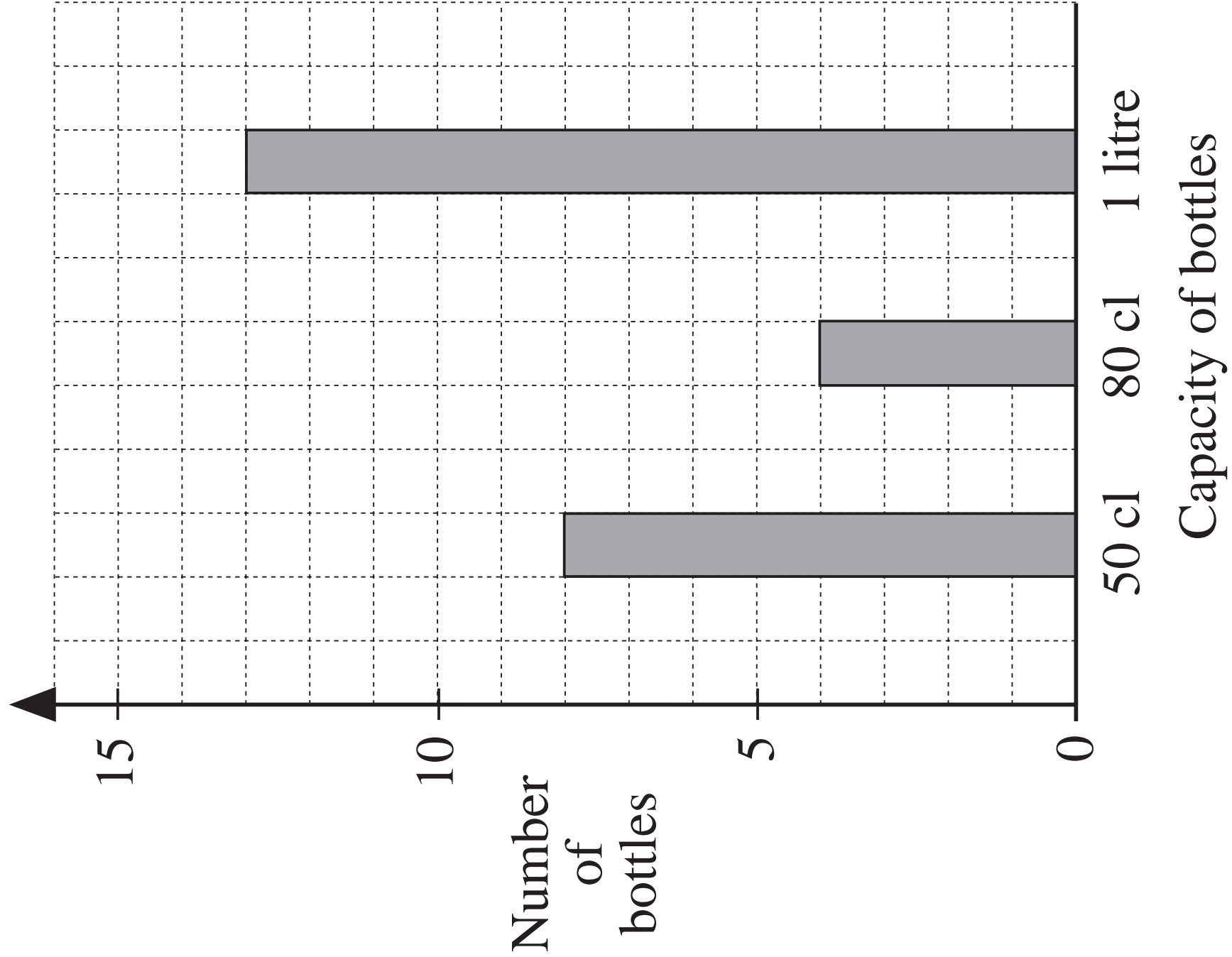

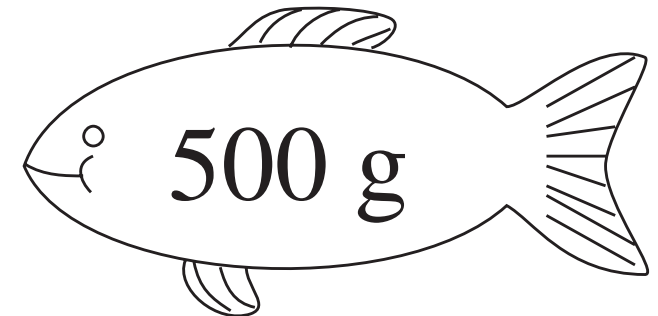
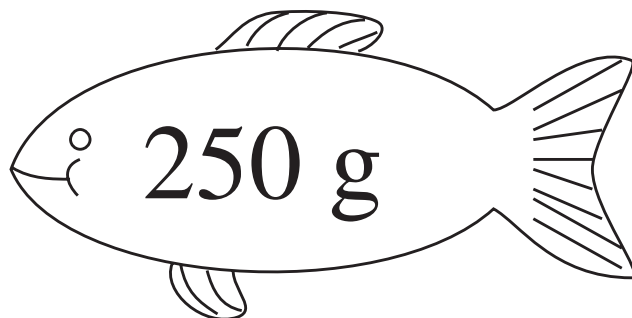
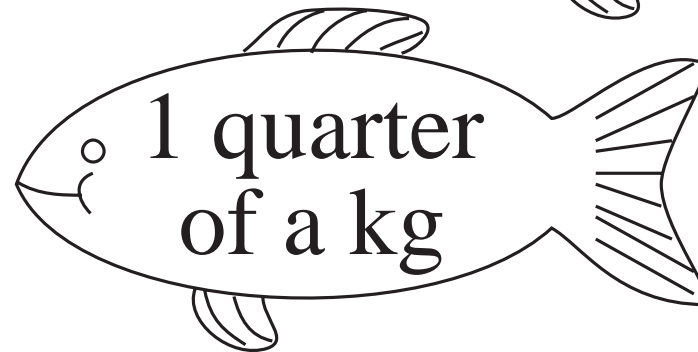
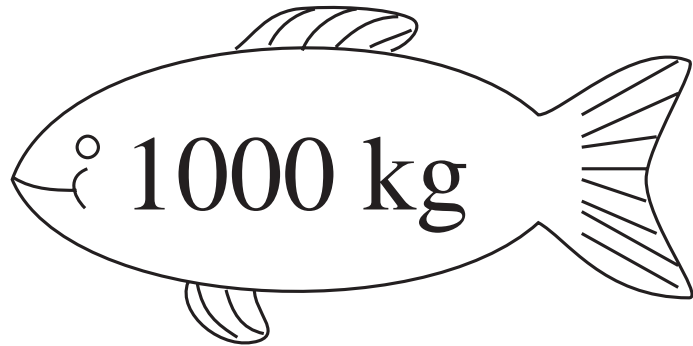
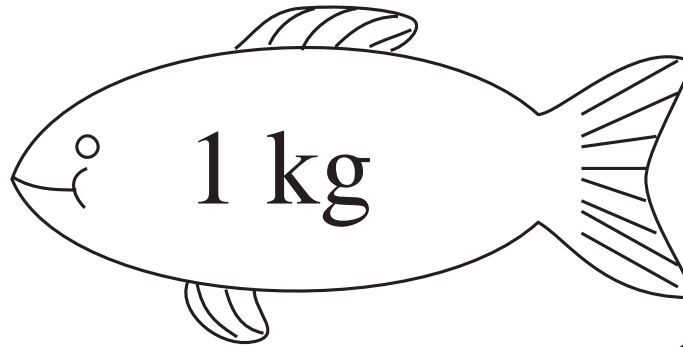
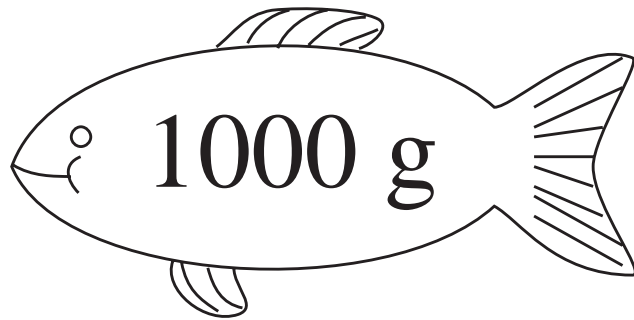

Weight groups	Girls	Boys
$25 \text{ kg} \leq a < 30 \text{ kg}$		
$30 \text{ kg} \leq b < 35 \text{ kg}$	 	
$35 \text{ kg} \leq c < 40 \text{ kg}$		
$40 \text{ kg} \leq d < 45 \text{ kg}$		
$45 \text{ kg} \leq e < 50 \text{ kg}$		



Number
of
pupils

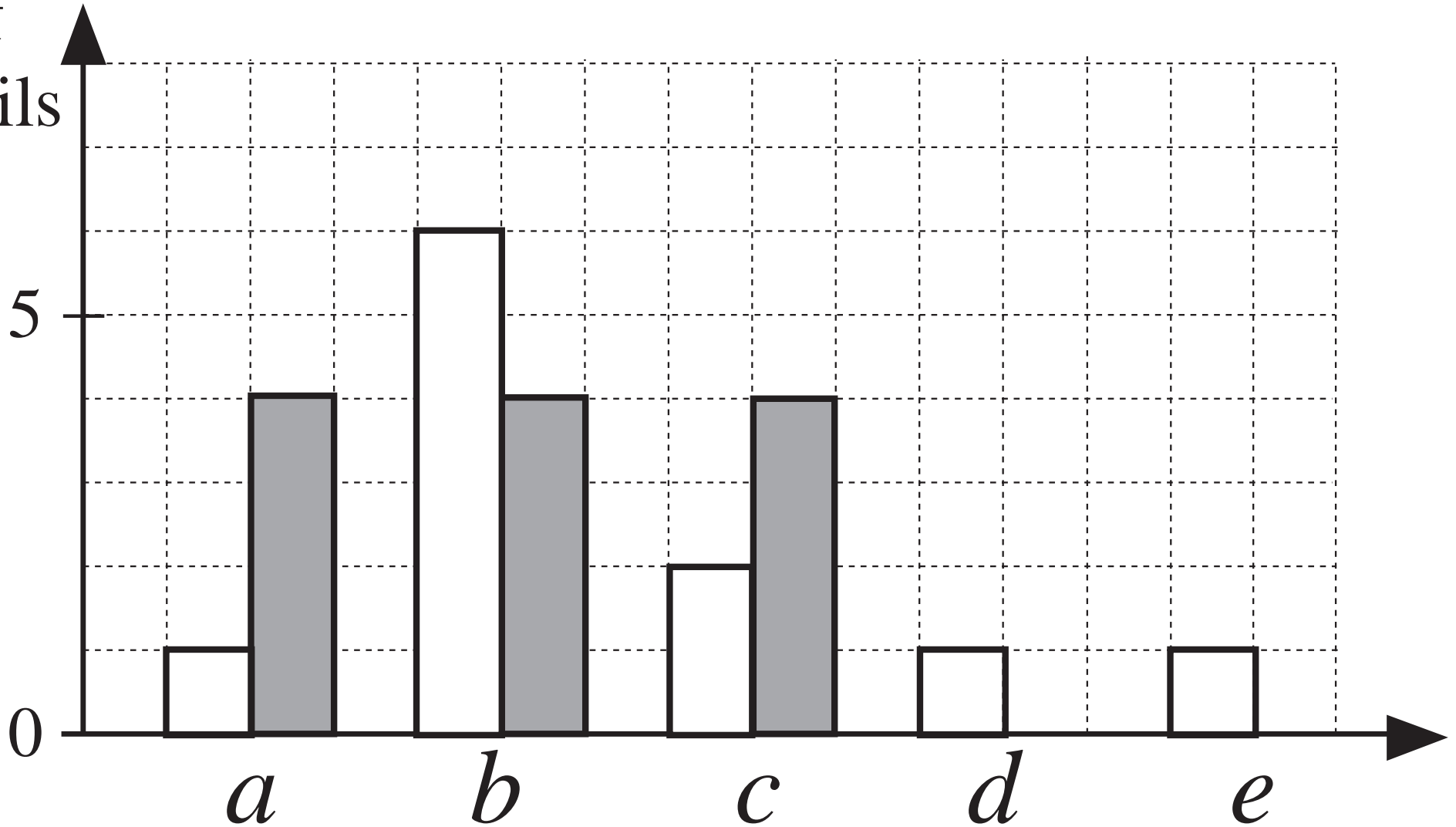

Weight groups

Weight in kg

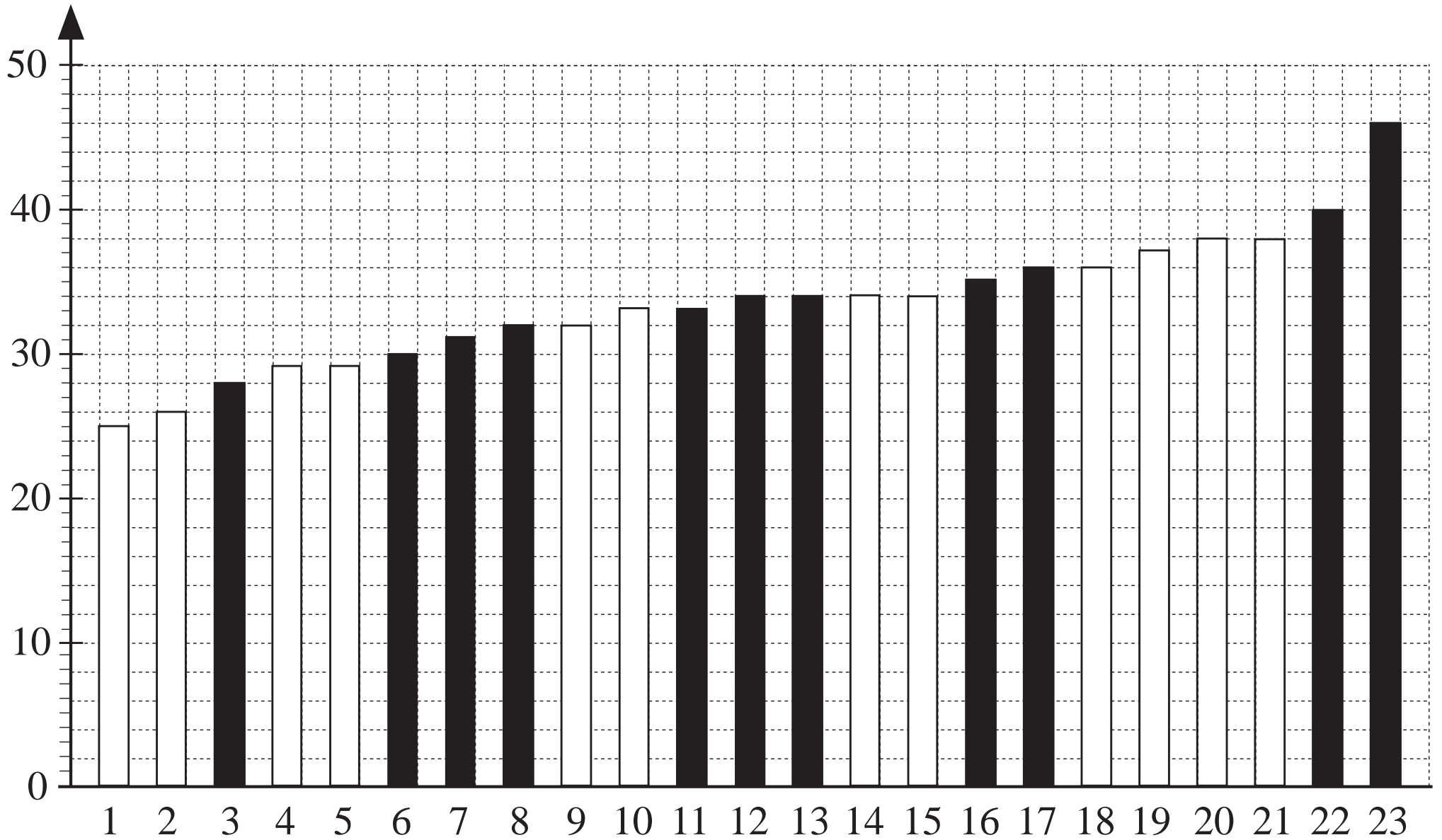

Pupils in class

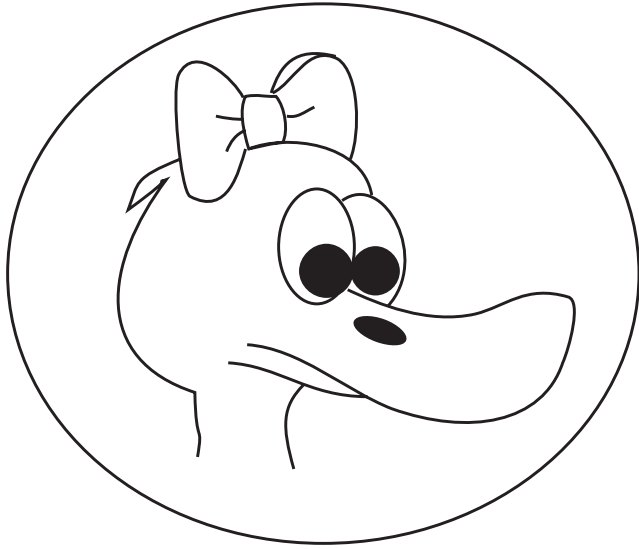

litre

day

m

year

ml

km

cl

month

kg

tonne

cm

g

mm

week

minute

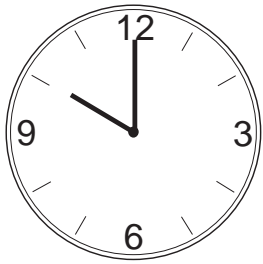
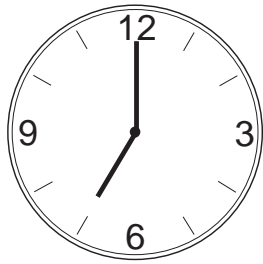
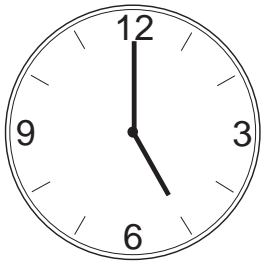
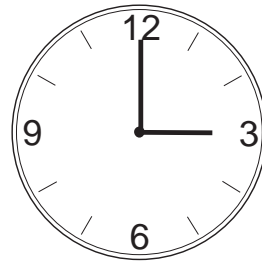
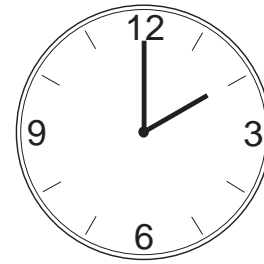
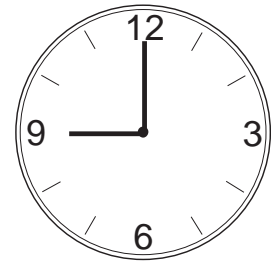
 hours hours hours hours hours hours

LP 24/5

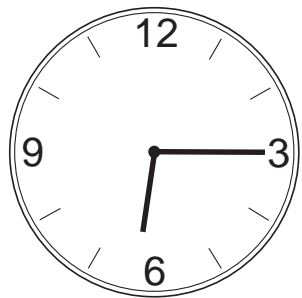
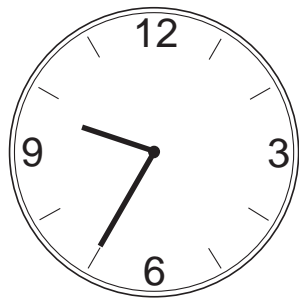
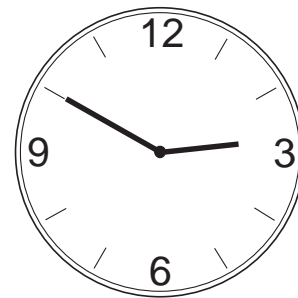
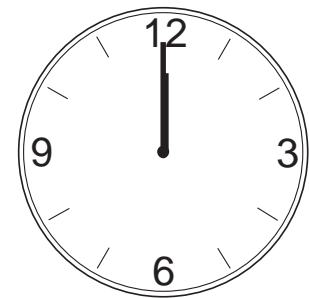
 hours minutes hours minutes hours minutes hours minutes

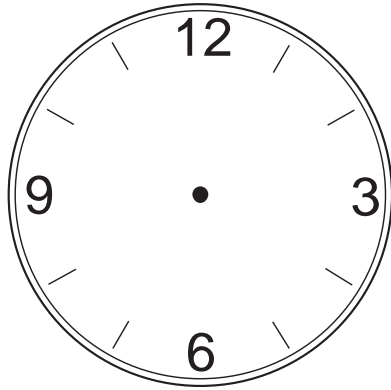

9 hours
45 minutes

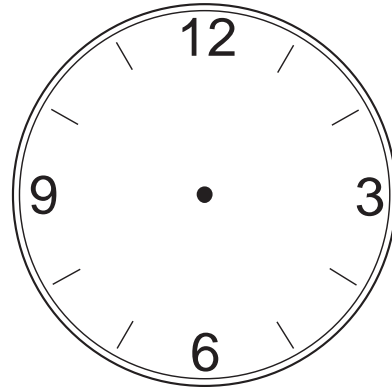

22 hours
15 minutes

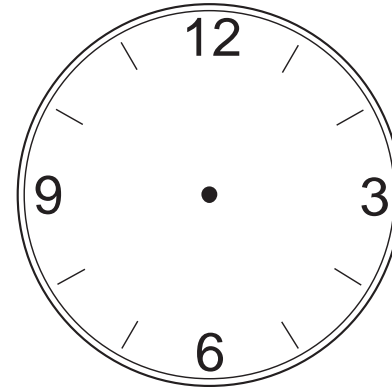

15 hours
30 minutes

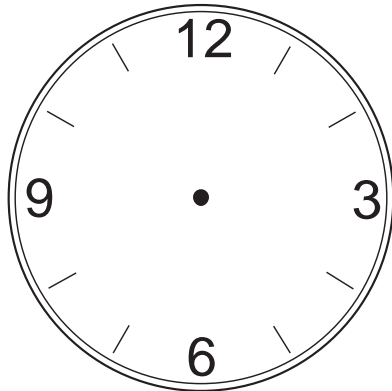

7 hours
45 minutes

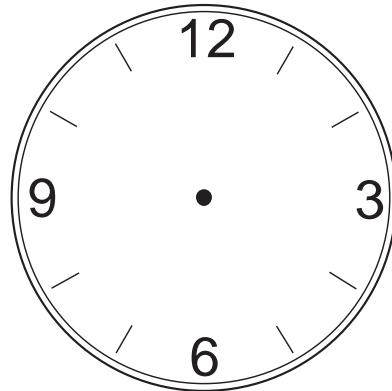

18 hours
55 minutes

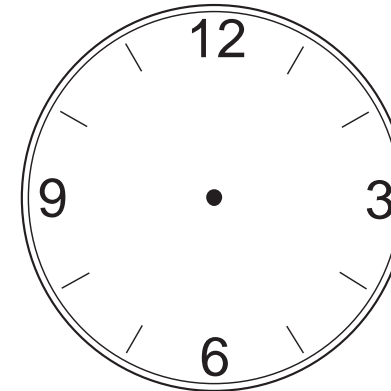

23 hours
15 minutes

chicken leg

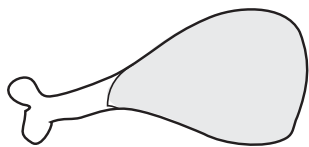
*a*

boy

*b*

sausages

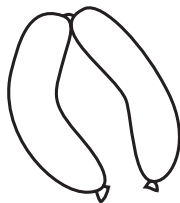
*c*

man

*d*

cheese

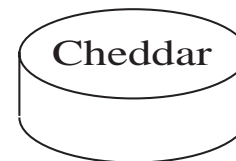
*e*

pig

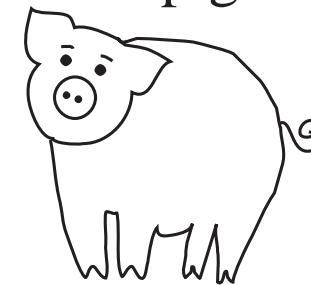
*f*

$$100 \text{ kg} < \bigcirc < 200 \text{ kg}$$

$$30 \text{ kg} < \bigcirc < 40 \text{ kg}$$

$$60 \text{ kg} < \bigcirc < 90 \text{ kg}$$

$$500 \text{ g} < \bigcirc < 800 \text{ g}$$

$$1000 \text{ g} < \bigcirc < 2000 \text{ g}$$

$$100 \text{ g} < \bigcirc < 200 \text{ g}$$

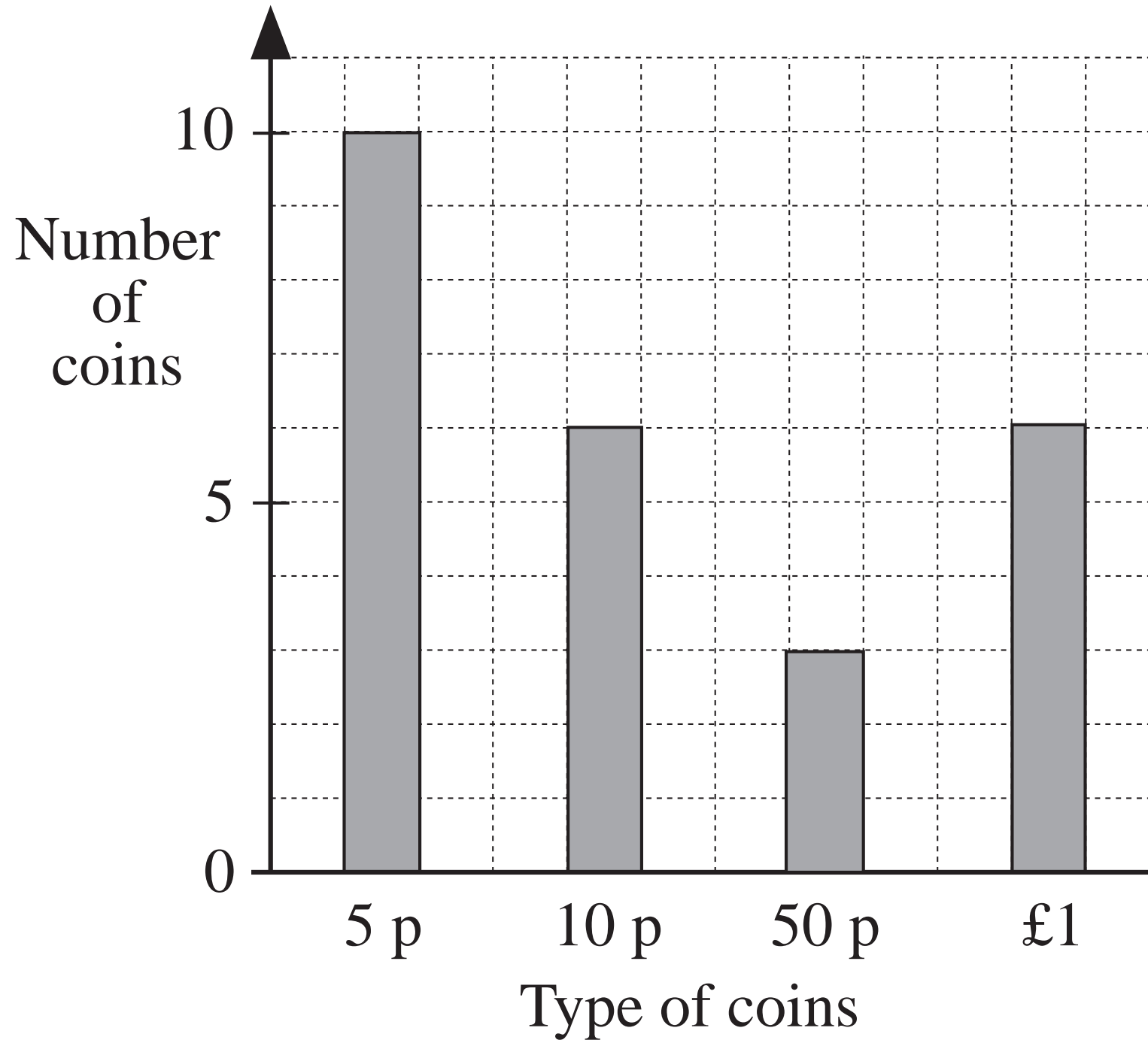

Marks scored	5	11	12	14	15	17	18	19	20
Number of pupils									

LP 26/2

Class data

Heads																	
Tails																	

Total number of Heads	
Total number of Tails	
Total number of Tosses	

LP 26/3



24 kg	25 kg	26 kg	27 kg	28 kg	29 kg	30 kg	31 kg	32 kg	33 kg	34 kg	35 kg

LP 26/4

**Number
thrown**

Class data

Totals

1																
2																
3																
4																
5																
6																

Total number of throws

--

Class data

1	2	3	4	5	6	Total number of throws

LP 27/4

Months	Jan.	Feb.	March	April	May	June	July	Aug.	Sep.	Oct.	Nov.	Dec.
Distance (km)												

LP 27/6b

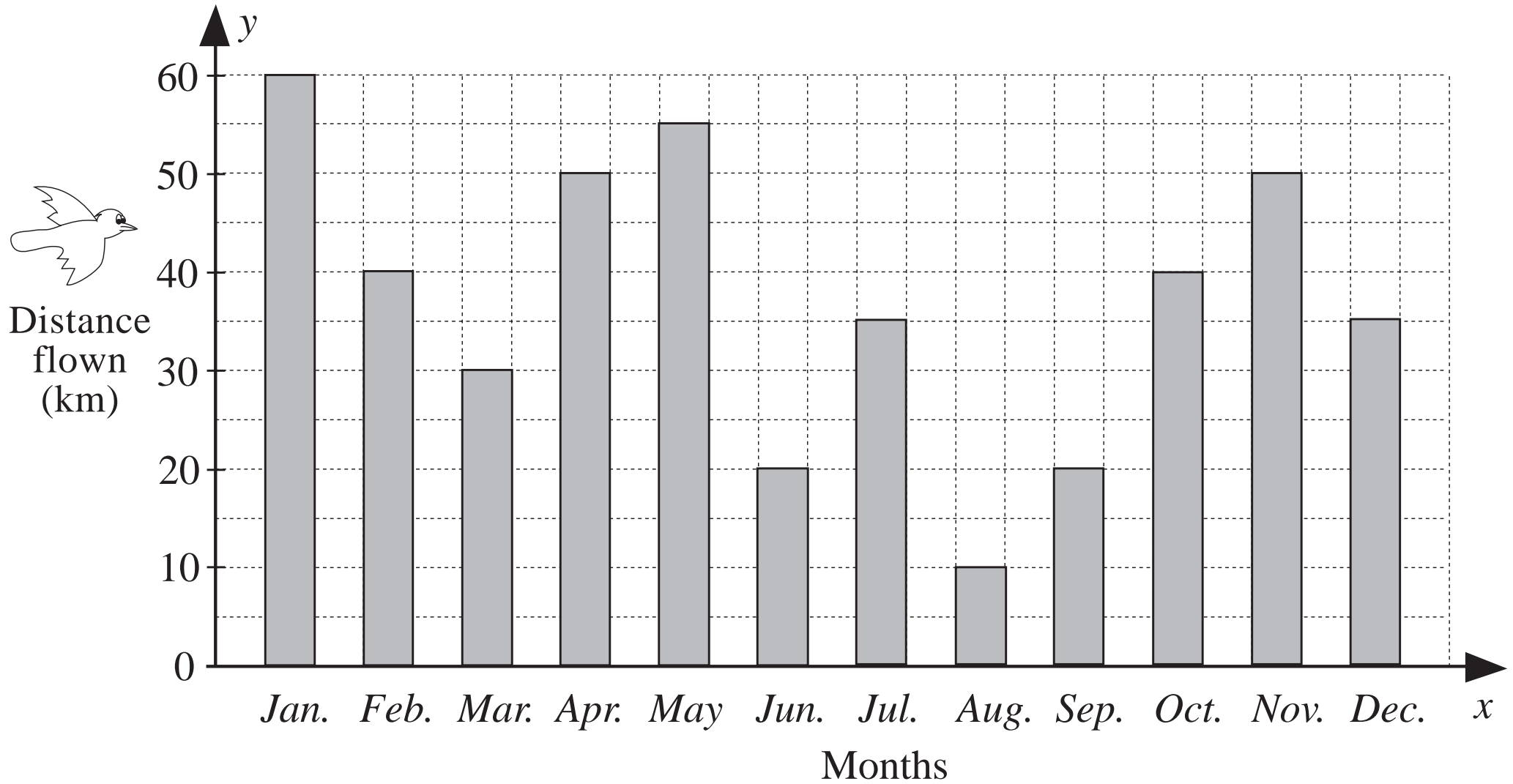

Number of pupils

Number
of times

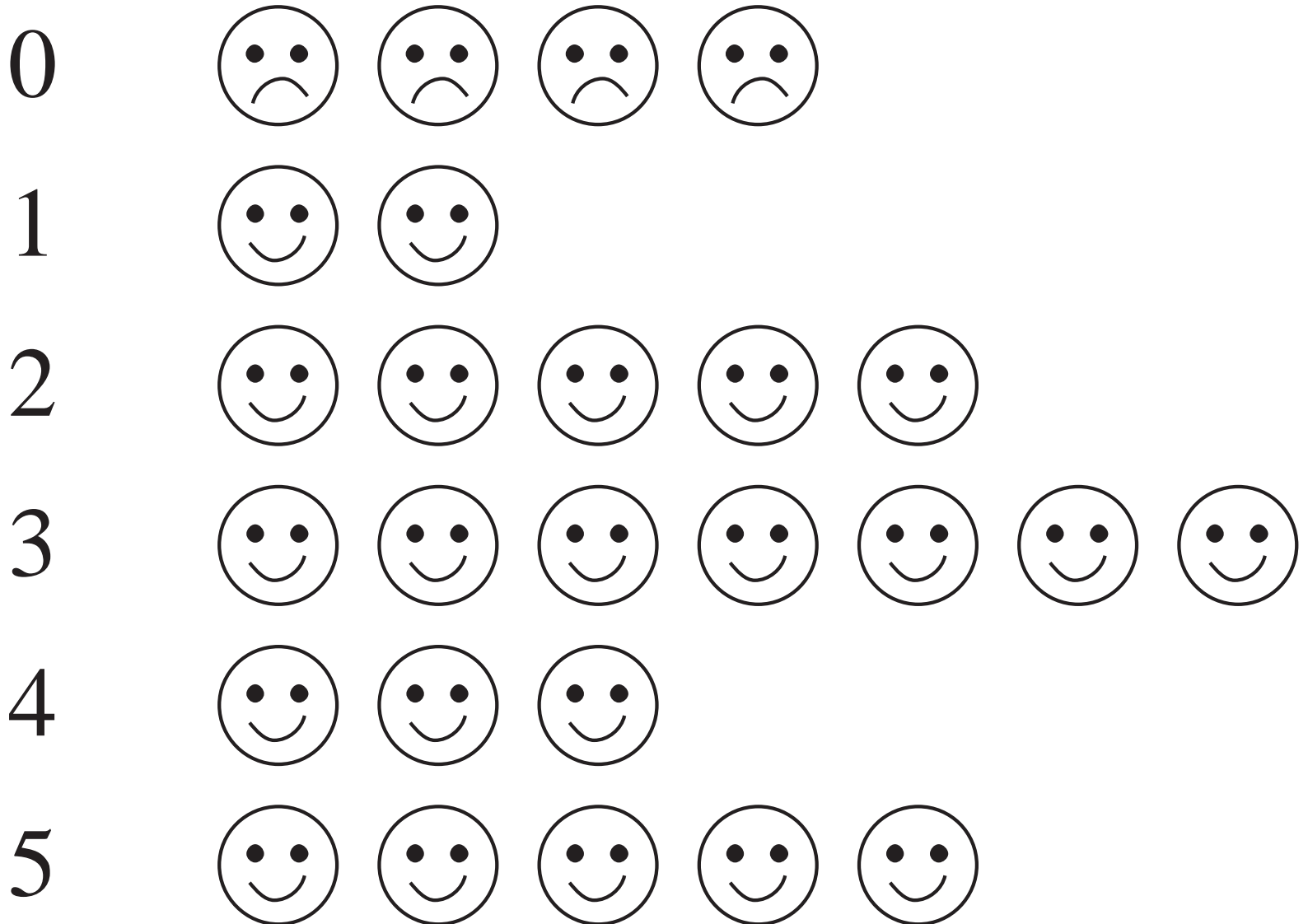

Number of swims	0	1	2	3	4	5
Number of pupils						

LP 27/7b

Size of head (cm)	47	48	49	50	51	52	53
Number of pupils							

LP 28/3a

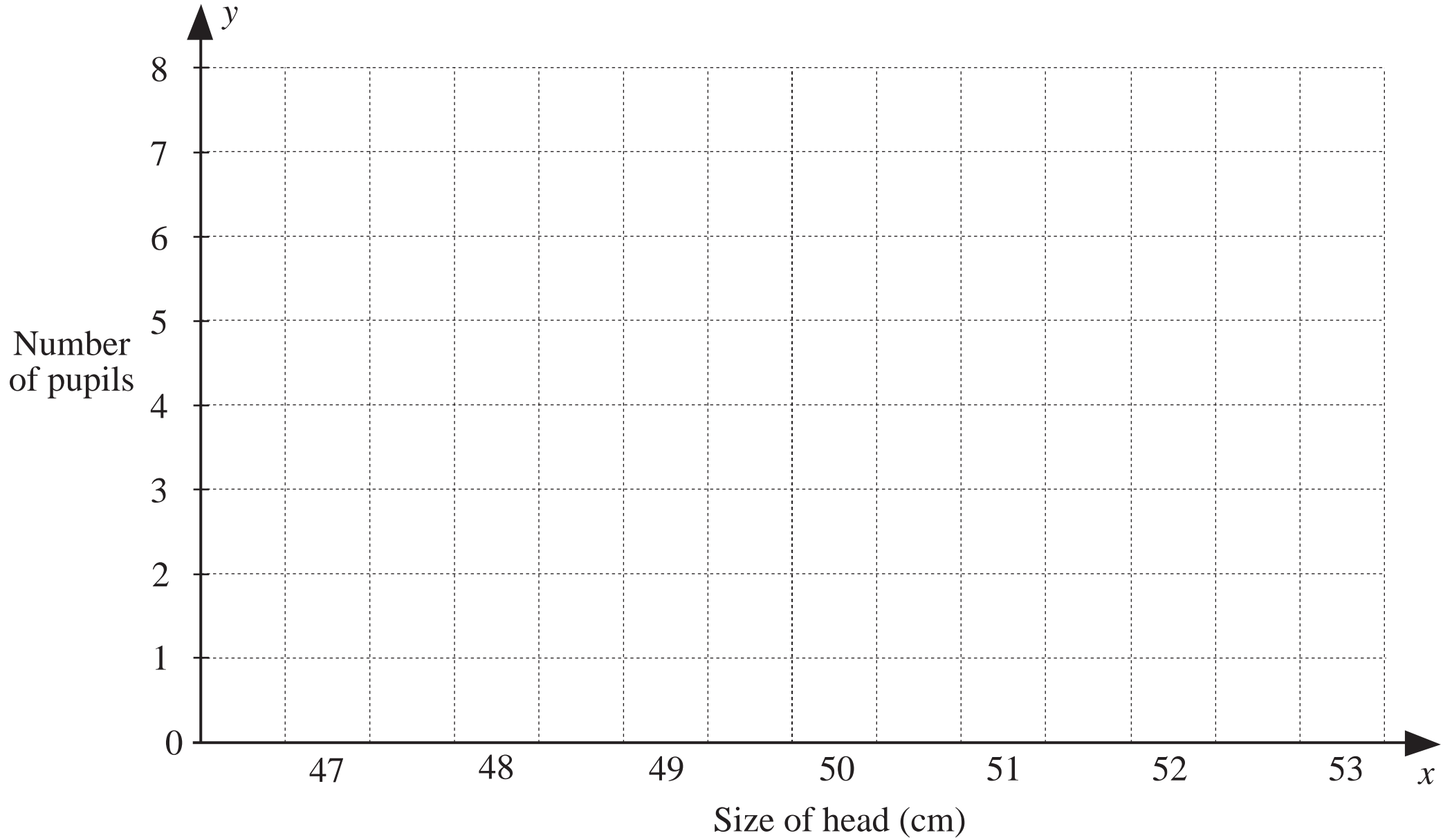

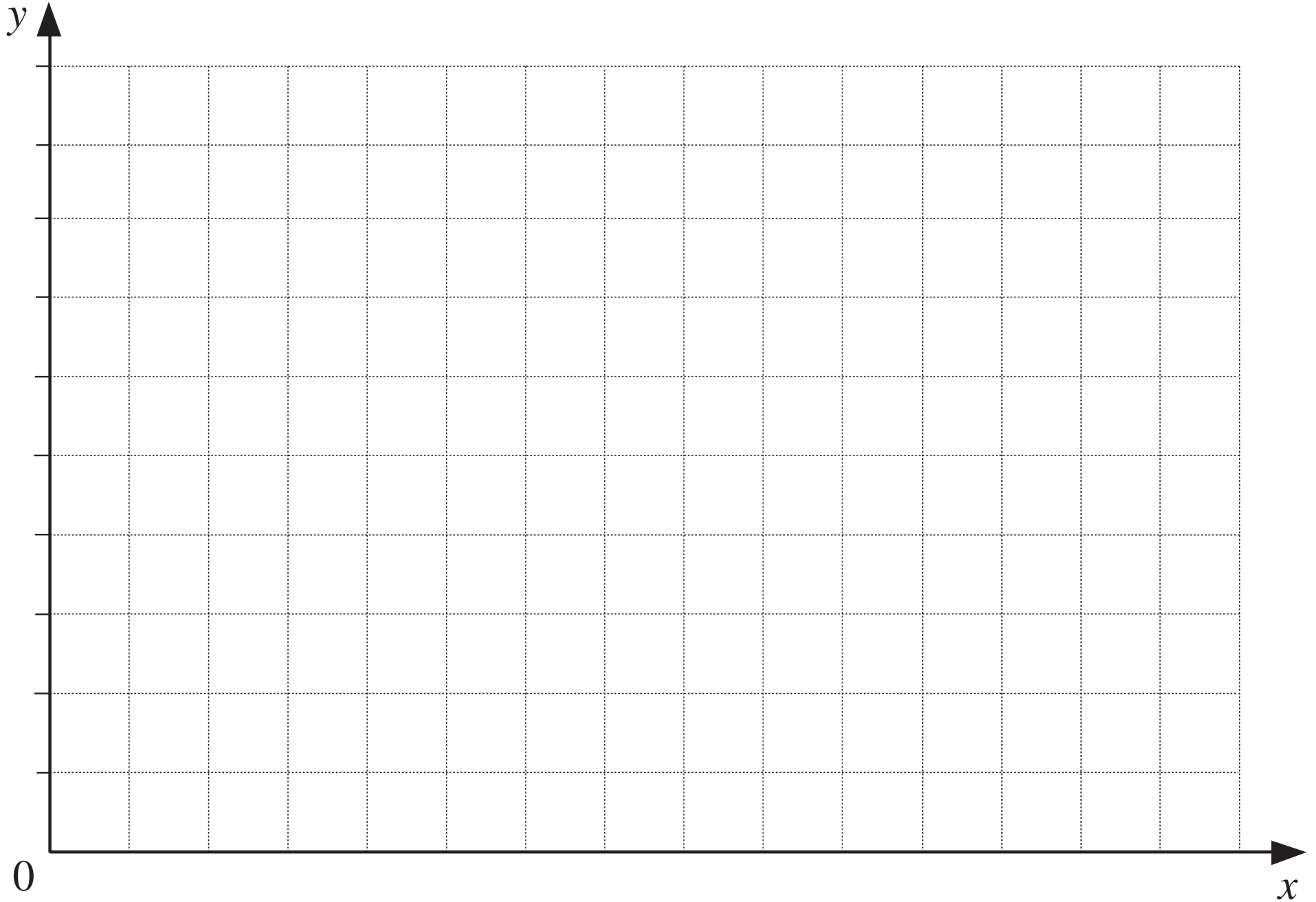

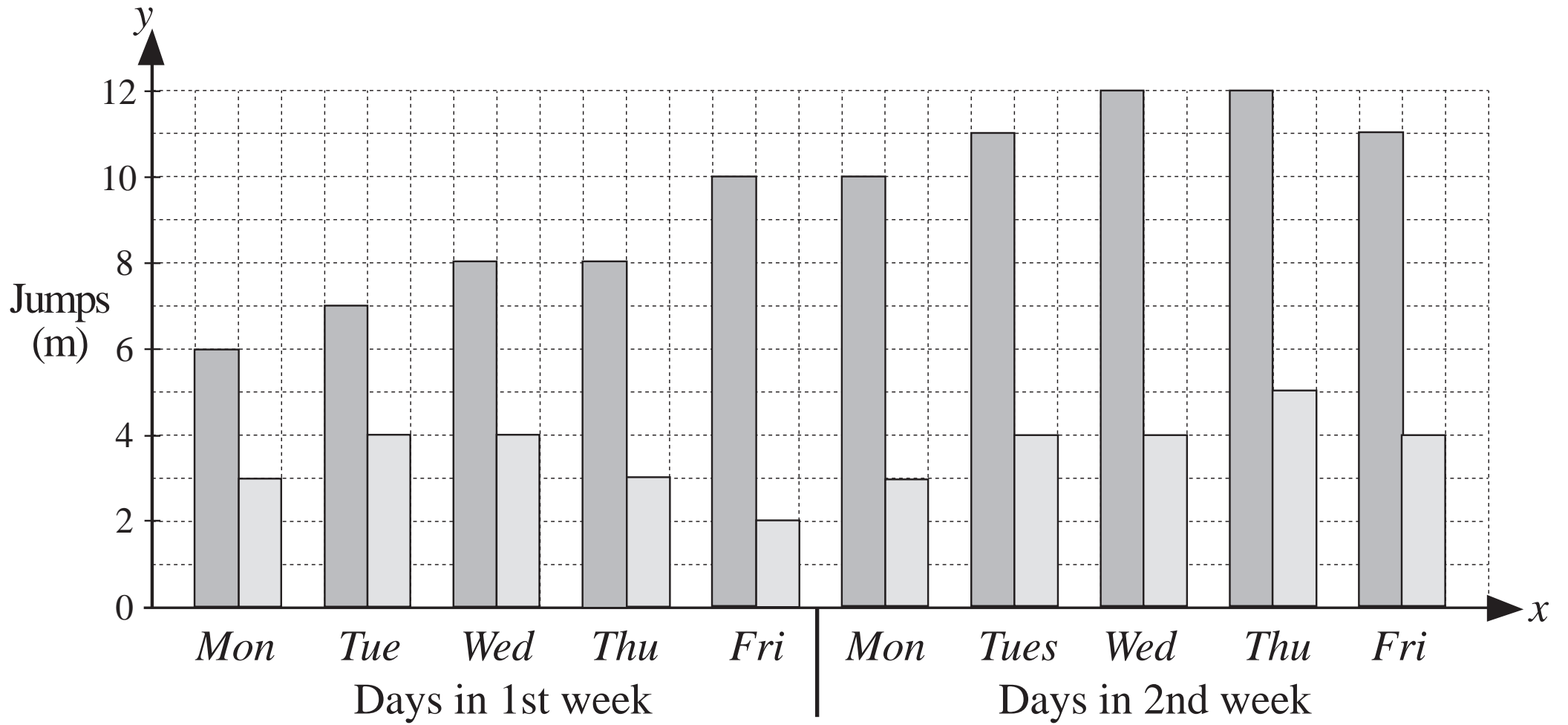

1st week
2nd week

Day	Mon.	Tue.	Wed.	Thu.	Fri.	Mon.	Tue.	Wed.	Thu.	Fri.
Kanga's jumps (m)										
Tangy's jumps (m)										

LP 28/5b

Time (min)	0	1	2	3	4	5	6
Height (m)	0	20	30	35	50	55	70

LP 28/6a

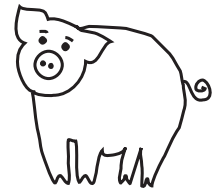
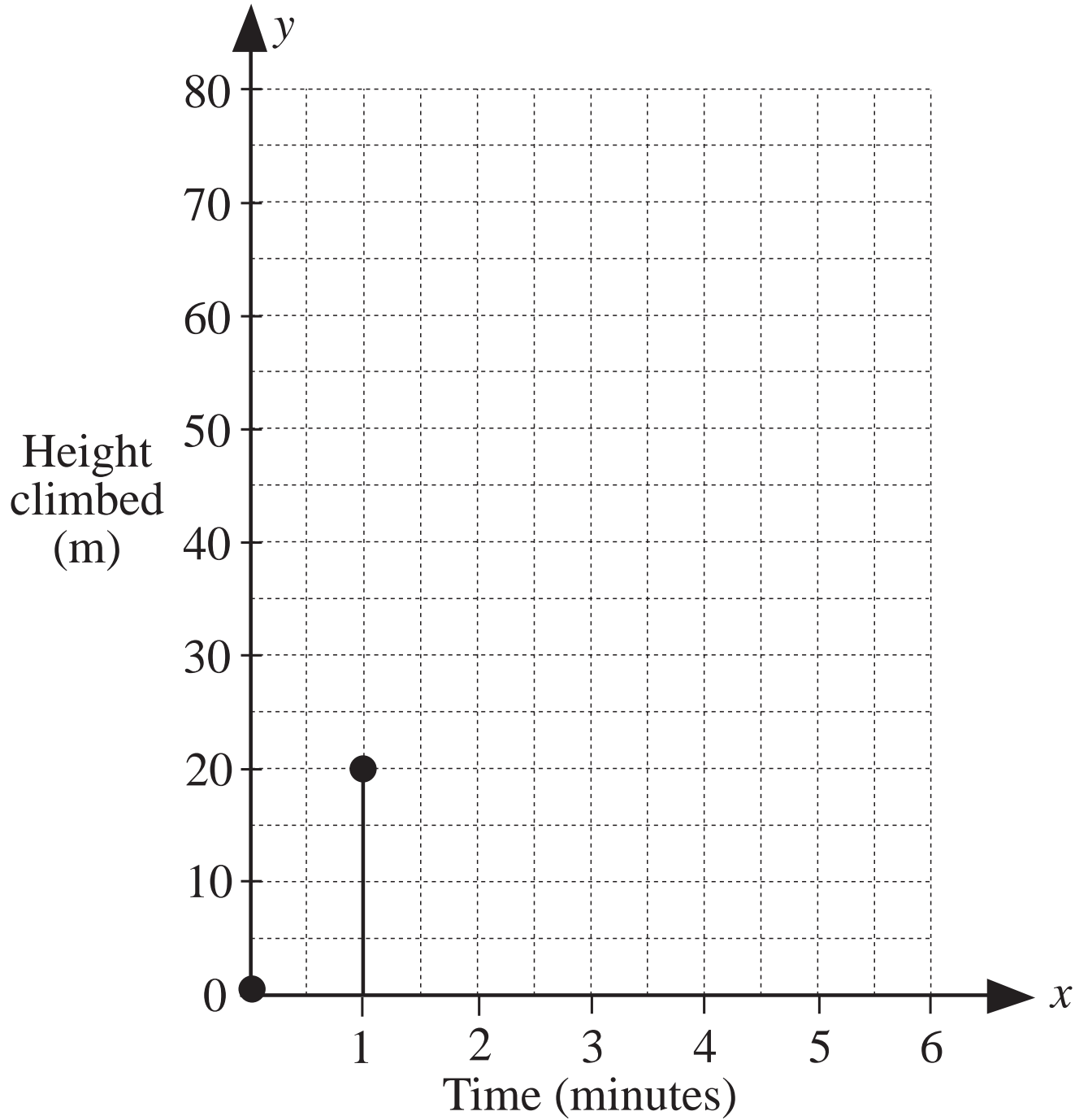

120 cm	121 cm	122 cm	123 cm	124 cm	125 cm	126 cm	127 cm	128 cm	129 cm

130 cm	131 cm	132 cm	133 cm	134 cm	135 cm	136 cm	137 cm	138 cm	139 cm	140 cm

LP 29/3

Bone number	1	2	3	4	5	6	7	8
Mass (g)								

LP 29/4b

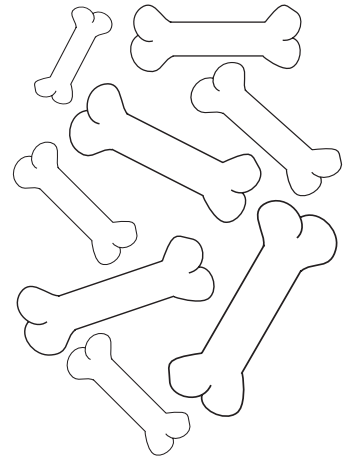
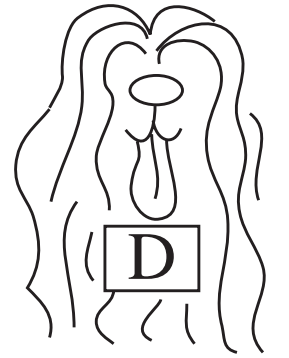
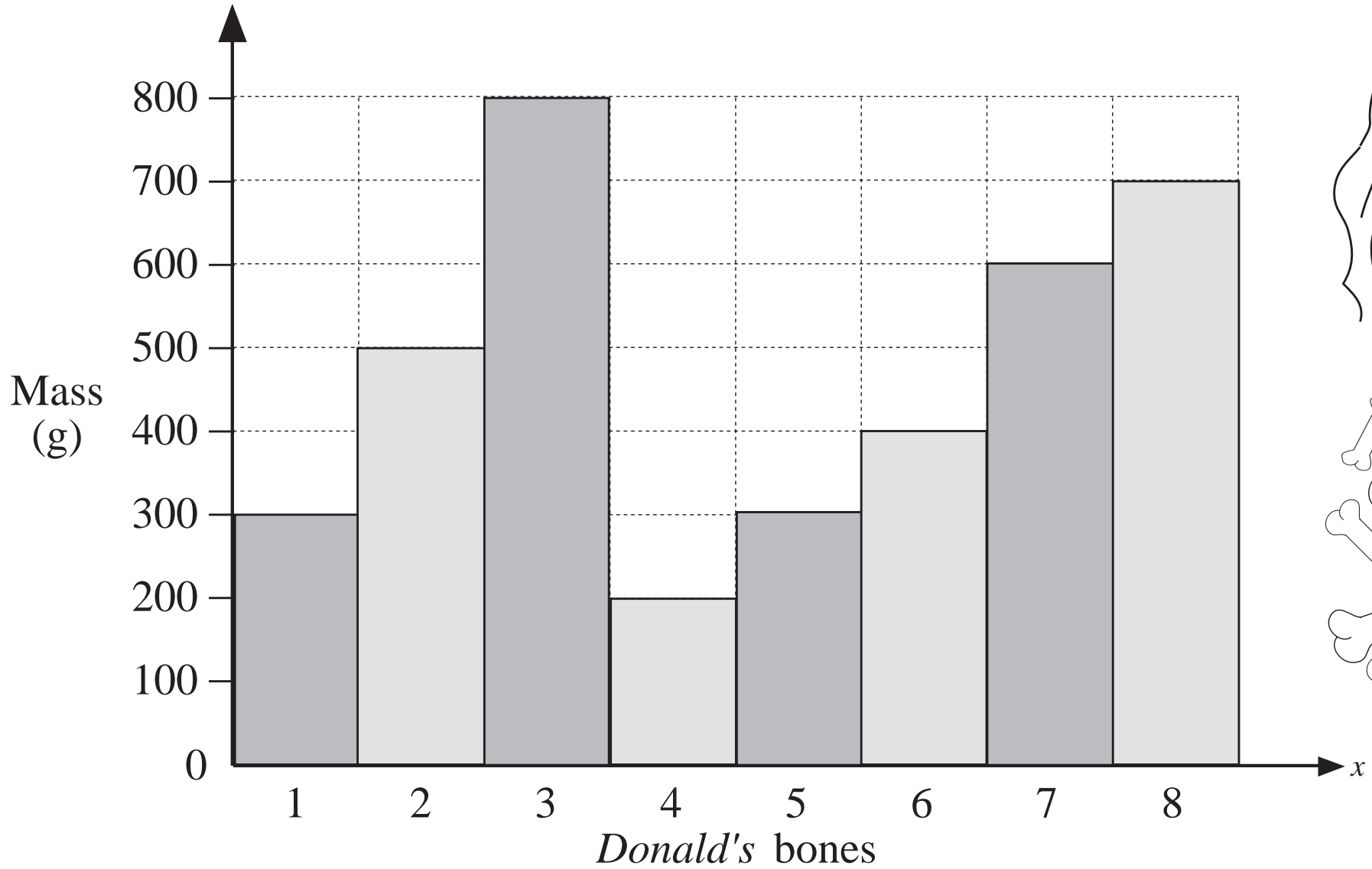

Number of times	0	1	2	3	4	5
Number of pupils	5	6	4	5	2	1

LP 29/5

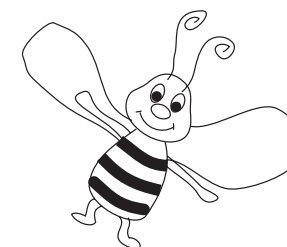

Year	1993	1994							
Population	200								

LP 29/6b



Population

