

1

How many apples are in:

- a) $\frac{1}{2}$ $\frac{1}{3}$ $\frac{1}{4}$ $\frac{1}{6}$ $\frac{1}{9}$ $\frac{1}{12}$
- b) $\frac{2}{2}$ $\frac{2}{3}$ $\frac{3}{4}$ $\frac{5}{6}$ $\frac{5}{9}$ $\frac{7}{12}$

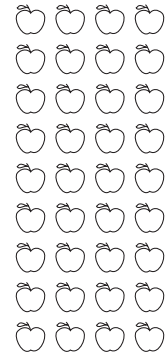

of the 36 apples?

2

What part of the ribbon is grey and what part is white? Write an addition and a subtraction about each ribbon.

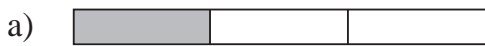

i) $\frac{\square}{3} + \frac{\square}{\square} = \frac{\square}{\square} = 1$

ii) $1 - \frac{\square}{\square} = \frac{2}{\square}$



i) $\frac{\square}{6} + \frac{\square}{\square} = \frac{\square}{\square} = 1$

ii) $1 - \frac{\square}{\square} = \frac{\square}{\square}$



i) $\frac{4}{\square} + \frac{\square}{\square} = \frac{\square}{\square} = 1$

ii) $1 - \frac{\square}{\square} = \frac{\square}{\square}$

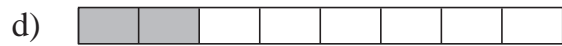

i) $\frac{2}{\square} + \frac{\square}{\square} = \frac{\square}{\square} = 1$

ii) $1 - \frac{\square}{\square} = \frac{\square}{\square}$

3

Fill in the missing fractions.

- a) $\frac{1}{5} + \square = 1$ $\square + \frac{3}{5} = 1$ $\frac{6}{5} - \square = 1$ $\square - \frac{4}{5} = 1$
- b) $\frac{3}{8} + \square = 1$ $\square + \frac{8}{8} = 1$ $\frac{10}{8} - \square = 1$ $\square - \frac{8}{8} = 1$
- c) $\frac{7}{10} + \square = 1$ $\square + \frac{5}{10} = 1$ $\frac{20}{10} - \square = 1$ $\square - \frac{5}{10} = 1$

1

Each rectangle is 1 unit. Write an addition and a subtraction about each diagram

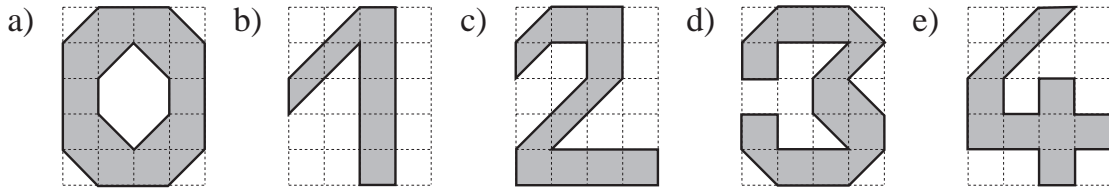

.....

2

Write the additions and subtractions with fractions in your exercise book and calculate the results.

- | | |
|---------------------------------------|--|
| a) 1 third + 1 third | b) 1 half + 1 half + 1 half |
| c) 3 quarters – 1 quarter | d) 2 fifths + 2 fifths |
| e) 5 sixths – 4 sixths | f) 1 seventh + 3 sevenths – 4 sevenths |
| g) 3 eighths + 10 eighths – 5 eighths | h) 8 ninths – 3 ninths |
| i) 10 tenths – 7 tenths + 2 tenths | j) 10 tenths – 8 tenths – 1 tenth |

3

Calculate the sums and differences.

- | | |
|------------------------------------|------------------------------------|
| a) $\frac{1}{2} + \frac{1}{2} =$ | b) $\frac{3}{5} + \frac{1}{5} =$ |
| c) $\frac{2}{3} - \frac{1}{3} =$ | d) $\frac{3}{4} - \frac{2}{4} =$ |
| e) $\frac{4}{5} - \frac{4}{5} =$ | f) $\frac{6}{6} + \frac{1}{6} =$ |
| g) $\frac{7}{10} - \frac{4}{10} =$ | h) $\frac{3}{20} + \frac{0}{20} =$ |

4

Hedgehog lives 400 m away from *Squirrel*.

One day, *Squirrel* went to visit *Hedgehog*.

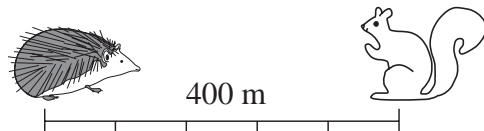

In the first minute, *Squirrel* covered 2 fifths of the route. In the second minute, *Squirrel* covered another 2 fifths of the route. How many metres did *Squirrel* still have to go?

Answer:

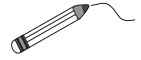

1

Join up the equal numbers.

	$\frac{2}{5}$	$\frac{1}{2}$		$\frac{4}{3}$	$\frac{5}{2}$	$\frac{10}{20}$
2	$\frac{3}{6}$	$\frac{4}{10}$	$\frac{5}{10}$	$1\frac{1}{3}$	$\frac{6}{3}$	$\frac{4}{2}$

2

Each rectangle is 1 unit. Colour the parts given.

a)

$\frac{1}{2}$	$\frac{2}{4}$	$\frac{3}{4}$	$\frac{4}{8}$

b)

$\frac{2}{3}$	$\frac{4}{6}$	$\frac{6}{9}$	$\frac{12}{18}$

3

Complete the diagrams to match the problems.

a) The distance between two cities is 369 km.

A family drove 1 third of the distance before lunch and completed the journey after lunch.

How far did they drive

..... km	
..... (part) (part)
i) before lunch	ii) after lunch?
..... km km

b) Some men are laying a pavement.

They have already paved 120 m, which is 2 thirds of the pavement.

..... m	
..... (part)	
..... (part)	
i) How much do they still have to do? m
ii) How long will the finished pavement be? m

4

a) $\frac{1}{5} + \frac{1}{5} + \frac{1}{5} = \square$	b) $\frac{3}{8} + \frac{2}{8} = \square$	c) $\frac{7}{12} - \frac{2}{12} = \square$
d) $\frac{11}{20} - \frac{9}{20} = \square$	e) $\frac{7}{10} + \frac{3}{5} = \square$	f) $\frac{3}{4} - \frac{3}{8} = \square$

1

Solve the problem. Do the calculations in your exercise book.

Sam has 80 fruit trees. Two eighths of them are apple trees, one quarter of them are pear trees, four sixteenths of them are cherry trees and the rest are plum trees.

- a) What kind of tree does he have most of?
- b) i) How many plum trees does Sam have?
- ii) What fraction of all Sam's trees are they?

2

Use the number lines to help you do the additions and subtractions.

a) $\frac{1}{2} + \frac{3}{4} + \frac{1}{2} =$

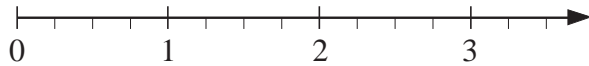

b) $\frac{4}{5} - \frac{1}{5} =$



c) $\frac{5}{6} + \frac{2}{6} - \frac{4}{6} =$

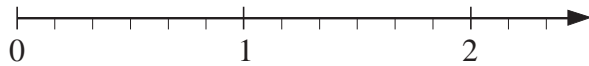

3

Solve the problems in your exercise book. Remember to convert the units.

- a) Mum bought a loaf which weighed $\frac{3}{4}$ kg. Rob ate $\frac{1}{5}$ of it.
How much bread did Rob eat?

- b) Diane spent £616, which was $\frac{2}{5}$ of her money.
How much money did Diane have before?

4

Work out the rule and complete the table. Write the rule in different ways.

<i>a</i>	$\frac{3}{10}$	$\frac{1}{10}$	$\frac{8}{10}$	$\frac{5}{10}$			$2\frac{1}{10}$	$\frac{1}{5}$		
<i>b</i>	$\frac{7}{10}$	$\frac{5}{10}$	$\frac{12}{10}$		$\frac{4}{10}$	1			$\frac{31}{10}$	$\frac{4}{5}$

Rule:

1

Compare the solids to the 1 unit. Complete the table.

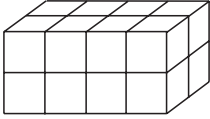
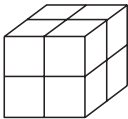
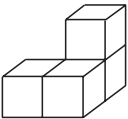
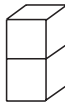
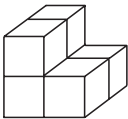
					
a)	$1 = \frac{\square}{\square}$				
b)		$1 = \frac{\square}{\square}$			
c)			$1 = \frac{\square}{\square}$		
d)				$1 = \frac{\square}{\square}$	
e)					$1 = \frac{\square}{\square}$

2

Do the additions and subtractions.

a) 63 chairs + 58 chairs + 120 chairs =

b) 3 quarters + 2 quarters + 1 quarter =

c) $4q + 7q + 11q =$

d) $\frac{3}{7} + \frac{2}{7} + \frac{4}{7} - \frac{5}{7} =$

e) 312 chicks + 243 dogs - 250 chicks + 21 dogs =

f) $4a + 6a + 8b - 5b =$

g) $\frac{1}{2} + \frac{1}{4} + \frac{3}{4} + \frac{1}{2} =$

3

Fill in the missing fractions.

a) $\frac{1}{6} + \square = 1$ $\square + \frac{3}{4} = 1$ $\frac{4}{3} - \square = 1$ $1 - \frac{2}{5} = \square$

b) $\frac{3}{7} + \square = 1$ $\square + \frac{5}{8} = 1$ $\frac{7}{6} - \square = 1$ $1 - \frac{4}{9} = \square$

4

Solve the problems in your exercise book.

a) David ate 2 fifths of a 500 g bar of chocolate. How many grams did he eat?

b) Marion spent £318, which was 2 thirds of her money. How much did she have at first?

1

Continue each sequence for 3 more terms. What rule did you use?

a) 740, 900, 1060, 1220, _____, _____, _____, Rule:

b) 6561, 2187, 729, 243, _____, _____, _____, Rule:

c) 8900, 7900, 7000, 6200, _____, _____, _____,
Rule:

d) $\frac{2}{9}$, $\frac{3}{9}$, $\frac{4}{9}$, $\frac{5}{9}$, _____, _____, _____, Rule:

2

Show the fractions in different ways.

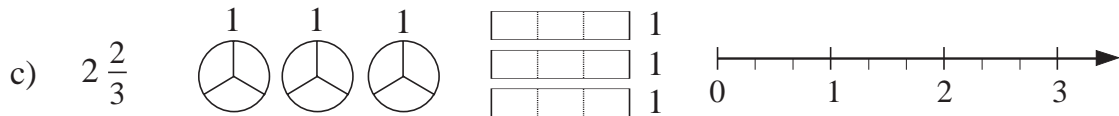
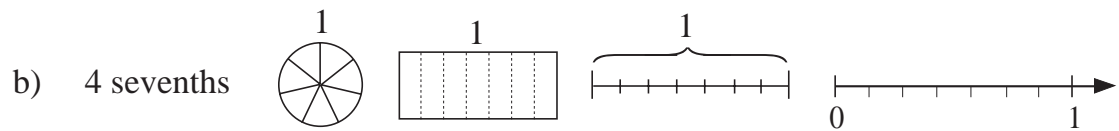
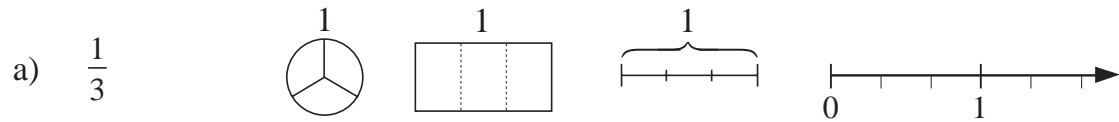

3

a) $4100 + 810 + 70 + 2400 =$

b) $5210 - 2300 =$

c) $3050 - 2500 + 800 =$

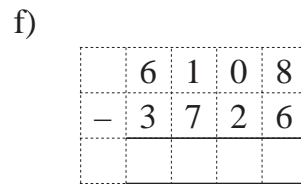
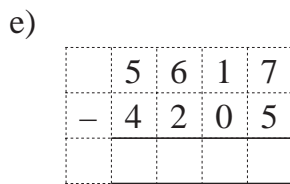
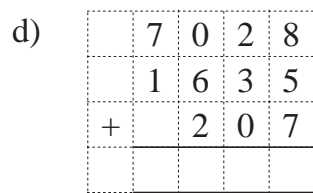

g) 2 sixths + 3 sixths =

h) 7 eighths - 3 eighths =

i) $\frac{5}{12} + \frac{1}{12} + \frac{3}{12} =$

j) $\frac{9}{10} - \frac{3}{10} =$

4

a) i) $40 \times 3 =$

ii) $280 \div 7 =$

iii) $30 \times 30 =$

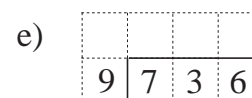
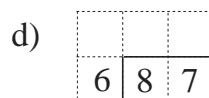
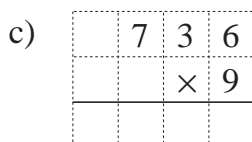
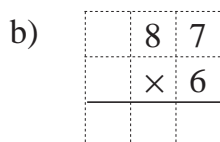

1

Write an equation and calculate the missing number in your exercise book.

- a) We thought of a number. If we added 420 to it we would get 3150. Which number were we thinking of?
- b) We thought of a number. If we subtracted 200 from it we would get 5002. Which number were we thinking of?
- c) We thought of a number. If we multiplied it by 7 we would get 203. Which number were we thinking of?
- d) We thought of a number. If we divided it by 7 we would get 203. Which number were we thinking of?

2

Fill in the missing numbers.

- a) $438 + \square = 1000$
- b) $\square - 4500 = 2900$
- c) $8200 - \square = 2800$
- d) $\frac{3}{8} + \square = \frac{7}{8}$
- e) $\square - \frac{2}{15} = \frac{11}{15}$
- f) $1 - \square = \frac{4}{7}$

3

Fill in the missing numbers.

- a) $9 \times \square = 387$
- b) $\square \div 9 = 387$
- c) $378 \div \square = 7$
- d) $\frac{1}{3} \times \square = \frac{3}{3}$
- e) $\square \div 2 = \frac{2}{5}$
- f) $\frac{5}{8} \div \square = \frac{1}{8}$

4

a) Complete the table if this is the rule. *Rule: B = 2 thirds of A.*

Write the rule in a different way.

A	3	6	9	12	15	18	21	24	27	30	33					450		$\frac{3}{4}$		
B	2	4										24	26	28	30		70		$\frac{2}{5}$	5

b) Find a rule and complete the table. Write the rule in different ways.

X	1	2	$\frac{3}{5}$	$\frac{4}{5}$		$1\frac{2}{5}$	$\frac{13}{5}$			20				
Y	$\frac{2}{5}$	$1\frac{2}{5}$	0	$\frac{1}{5}$	$\frac{3}{5}$			$\frac{6}{5}$	$5\frac{2}{5}$		40			

Rule:

1

Solve the problem in your exercise books. Write the answer here.

A roll of film is 675 m long.

- a) How long are 9 rolls of film?
- b) How long is 3 fifths of a roll of film?

2

Complete the table.

Capacity	100 litres	800 litres	1 litre	8 litres	10 cl	80 cl
1 half	<i>l</i>	<i>l</i>	cl	cl	ml	ml
1 quarter	<i>l</i>	<i>l</i>	cl	cl	ml	ml
1 tenth	<i>l</i>	<i>l</i>	cl	cl	ml	ml
1 fifth	<i>l</i>	<i>l</i>	cl	cl	ml	ml
2 fifths	<i>l</i>	<i>l</i>	cl	cl	ml	ml
3 tenths	<i>l</i>	<i>l</i>	cl	cl	ml	ml

3

Complete the table.

Mass	1 kg	12 kg	24 kg	200 g	400 g	6 tonnes
$\frac{1}{2}$	g	g	g	g	g	kg
$\frac{1}{4}$	g	g	g	g	g	kg
$\frac{1}{10}$	g	g	g	g	g	kg
$\frac{1}{5}$	g	g	g	g	g	kg
$\frac{2}{5}$	g	g	g	g	g	kg

4

Complete the tables to show the capacity and mass of clear water at 4° Celsius.

a)

Capacity	1 litre	7 litres		$\frac{1}{2}$ litre	<i>l</i>	100 <i>l</i>		$\frac{3}{4}$ litre
Mass	1 kg		4 kg	g	250 g		50 kg	g

b)

Capacity	1 ml	8 ml		1 cl		200 ml		$1\frac{1}{2}$ ml
Mass	1 g		13 g		10 g		50 g	

1

Fill in the missing numbers.

- a) $5600 \xrightarrow{+400} \square \xrightarrow{+500} \square \xrightarrow{+300} \square \xrightarrow{+200} \square$
- b) $5600 \xrightarrow{+500} \square \xrightarrow{+200} \square \xrightarrow{+400} \square \xrightarrow{+300} \square$
- c) $5600 \xrightarrow{+400} \square \xrightarrow{-500} \square \xrightarrow{+300} \square \xrightarrow{-200} \square$
- d) $5600 \xrightarrow{-400} \square \xrightarrow{-500} \square \xrightarrow{-300} \square \xrightarrow{-200} \square$
- e) $5600 \xrightarrow{-300} \square \xrightarrow{-200} \square \xrightarrow{-400} \square \xrightarrow{-500} \square$

2

Write a plan, estimate, calculate, check and write the answer as a sentence in your exercise book.

- a) A farmer collected the cherries from his orchard and packed them in boxes. Each box held 18 kg of cherries.
He filled 79 boxes and loaded them on a lorry to take to the supermarket.
If an empty box weighed 2 kg, what was the total load on the lorry?
- b) The total mass of 8 containers of building material is 5600 kg.
If the containers weighed 1600 kg in total when they were empty, how much building material is in each container?

3

- a)  How many small squares are needed to cover this rectangle? small squares

b) Draw a rectangle which needs:

i) $\frac{1}{2}$

ii) $\frac{2}{3}$

iii) $\frac{3}{4}$

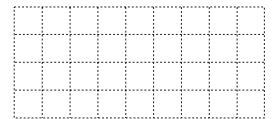
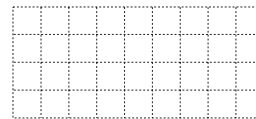
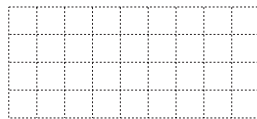
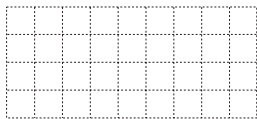

iv) $\frac{5}{9}$



of this number of small squares to cover it.

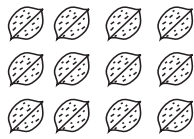

4

Complete the table to show different parts of the total number of walnuts.

Part of total	$\frac{1}{2}$	$\frac{1}{3}$	$\frac{1}{6}$	$\frac{3}{2}$	$\frac{3}{3}$	$\frac{3}{6}$	$\frac{2}{3}$	$\frac{4}{6}$	$\frac{6}{3}$	
Number of 										

1

Show the fractions in different ways.

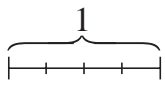
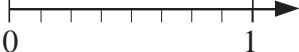
a) $\frac{1}{4}$    

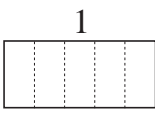
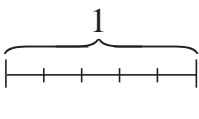
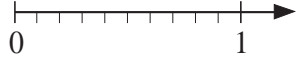
b) three fifths    

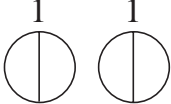
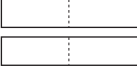
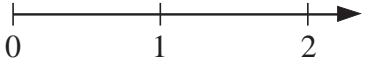
c) $1\frac{1}{2}$   

2

Practise calculation.

a) $30 \times 4 =$ $360 \div 9 =$ $40 \times 40 =$ $240 \div 20 =$

b)

	4	7	
	×	7	

c)

	3	6	8
		×	6

d)

5	9	3

e)

7	5	4	6

3

Complete the table if the rule is : $B = 2$ fifths of A .

A	0	5	10	15	20	25	30					100		2
B	0	2						14	16	18	20		100	

Write the rule as: $A = \dots\dots\dots$

4

Which numbers can be written instead of the star?

a) $1525 < \star < 1530$ $\star : \dots\dots\dots$

b) $\frac{6}{11} \leq \star < 1$ $\star : \dots\dots\dots$

c) $1\frac{1}{8} \leq \star < 1\frac{1}{2}$ $\star : \dots\dots\dots$

5

Round these measures to the nearest

a) litre: $234 \text{ cl} \approx$ $375 \text{ cl} \approx$ $4390 \text{ cl} \approx$

b) km: $4.6 \text{ km} \approx$ $3 \text{ km } 45 \text{ cm} \approx$ $6390 \text{ m} \approx$

c) kg: $1\frac{3}{8} \text{ kg} \approx$ $1456 \text{ g} \approx$ $5.5 \text{ kg} \approx$

1

Change the quantities to the units required and write them in the table.

	H 100	T 10	U 1	t $\frac{1}{10}$	h $\frac{1}{100}$	
a) 35 cm 6 mm = 1 m 20 cm 4 mm = 3208 mm =						(cm)
b) 1 m 63 cm = 28 m 40 cm = 605 cm =						(m)
c) £8 70 p = £41 5 p = £120 15 p = 3648 p =						(£)

2

Write the sums in the table.

	H 100	T 10	U 1	t $\frac{1}{10}$	h $\frac{1}{100}$
a) $5 \times 10 + 3 \times 1 + 2 \times \frac{1}{10}$					
b) $3 \times 100 + 4 \times 10 + 7 \times 1 + 5 \times \frac{1}{10}$					
c) $6 \times 1 + 8 \times \frac{1}{10} + 4 \times \frac{1}{100}$					
d) $9 \times \frac{1}{10} + 2 \times \frac{1}{100}$					
e) $6 \times 10 + 0 \times 1 + 3 \times \frac{1}{10}$					

3

Write the quantities in different forms in your exercise book.

- a) i) £4.99 ii) £41.05 iii) £204.50
 b) i) 4.3 cm ii) 63.5 cm iii) 8.24 m iv) 57.06 m

4

a) Draw these lines with a ruler in your exercise book and label them.

$$a = 87 \text{ mm}, \quad b = 11.6 \text{ cm}, \quad c = 6 \text{ cm } 4 \text{ mm}, \quad d = 7\frac{5}{10} \text{ cm}$$

b) Measure the length of these line segments and write it in different forms.

i) 

ii) 

1

Join up the decimal numbers to the matching point on the number line.

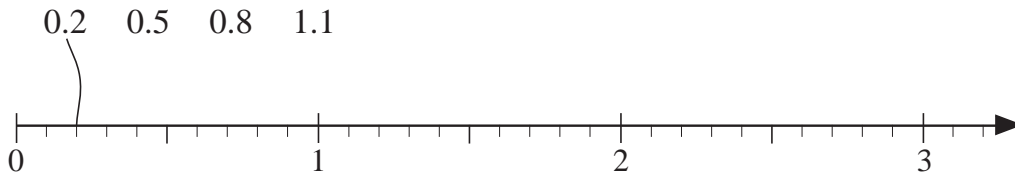
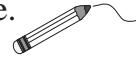

Continue the pattern. Write the decimal numbers as fractions below the line.

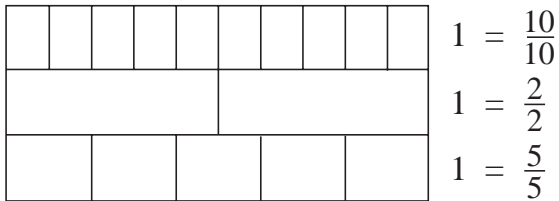
2Find **equivalent** fractions in the diagram. Write them as decimals too.**3**

Complete the table and the equations. Follow the pattern.

H 100	T 10	U 1	t $\frac{1}{10}$	h $\frac{1}{100}$	
	2	5	1	8	$2 \times 10 + 5 \times 1 + 1 \times \frac{1}{10} + 8 \times \frac{1}{100} = 25 + \frac{18}{100} = 25.18$
1	0	4	3		= =
		6	5	7	= =
					$8 \times 100 + 0 \times 10 + 3 \times 1 + 4 \times \frac{1}{10} =$
					= $26 + \frac{7}{10} =$
					= = 10.05

4

Convert the quantities. Follow the pattern. Fill in the missing numbers.

a) $5 \text{ cm } 8 \text{ mm} = 5 \frac{8}{10} \text{ cm} = 5.8 \text{ cm}$

$36 \text{ cm } 5 \text{ mm} = \boxed{} \text{ mm} = \boxed{} \text{ cm}$

b) $8 \text{ m } 63 \text{ cm} = 863 \text{ cm} = 8 \frac{63}{100} \text{ m} = 8.63 \text{ m}$

$1 \text{ m } 24 \text{ cm} = \boxed{} \text{ cm} = \boxed{} \text{ m} = \boxed{} \text{ m}$

$25 \text{ m } 70 \text{ cm} = \boxed{} \text{ cm} = \boxed{} \text{ m} = \boxed{} \text{ m}$

1

Fill in the missing numbers and write the quantities in the place-value table using the units given.

- a) $15\text{ m} + \frac{1}{10}\text{ m} + \frac{8}{100}\text{ m} = \boxed{}\text{ m } \boxed{}\text{ cm}$
 b) $300.45\text{ m} = \boxed{}\text{ m } \boxed{}\text{ cm}$
 c) $7\frac{8}{100}\text{ litres} = \boxed{}\text{ litres } \boxed{}\text{ cl}$
 d) $\text{£}106.80 = \text{£ } \boxed{} \boxed{}\text{ p}$
 e) $28.5\text{ kg} = \boxed{}\text{ kg } \boxed{}\text{ g}$

H 100	T 10	U 1	t $\frac{1}{10}$	h $\frac{1}{100}$	
					(m)
					(m)
					(ℓ)
					(£)
					(kg)

2

Write the numbers in increasing order in your exercise book.

- a) 9999, 683, 2015, 71, 452, 3, 2009, 460
 b) $\frac{4}{15}$, $\frac{14}{15}$, $\frac{11}{15}$, $\frac{1}{15}$, $\frac{20}{15}$, $\frac{3}{15}$, $\frac{16}{15}$, $\frac{30}{15}$
 c) 0.3, 3.1, 7.0, 0.08, 0.32, 7, 0.4, 6.9

3

Compare the pairs of numbers and fill in the missing signs (<, >, =)
 Use the diagrams to help you.

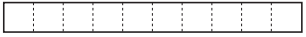
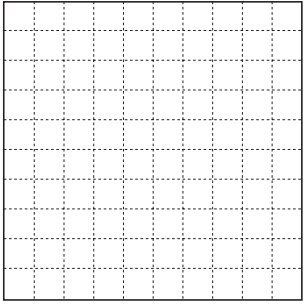
- a) $\frac{2}{10} \square \frac{7}{10}$ $\frac{8}{10} \square 0.9$ $0.6 \square 0.3$  1
- b) $\frac{15}{100} \square \frac{72}{100}$ $\frac{43}{100} \square 0.70$ $0.52 \square 0.49$  1
- c) $0.04 \square 0.1$ $\frac{2}{10} \square \frac{18}{100}$ $0.27 \square 0.3$
- d) $\frac{1}{5} \square 0.2$ $\frac{2}{5} \square 0.3$ $\frac{3}{10} \square 0.6$
- e) $\frac{1}{5} \square \frac{17}{100}$ $\frac{3}{10} \square 0.51$ $\frac{78}{100} \square 0.53$

4

Calculate the quantities and compare each pair. Write <, > or = in the boxes.

- a) $\frac{1}{5}$ of 450 m = 0.28 of 1 km =
 b) 0.6 of 150 litres = $\frac{7}{10}$ of 100 litres =
 c) $\frac{1}{4}$ of 28 kg = 0.5 of 14 kg =
 d) 0.25 of £220 = $\frac{3}{4}$ of £90 =

1

Convert the fractions to decimals and the decimals to fractions.

a) $\frac{1}{2} =$ $\frac{2}{2} =$ $\frac{5}{2} =$ $6\frac{1}{2} =$

$1 = \frac{10}{10}$



b) $0.1 =$ $0.2 =$ $0.5 =$ $0.9 =$

$1 = \frac{100}{100}$

c) $\frac{1}{4} =$ $\frac{3}{4} =$ $2\frac{1}{4} =$ $\frac{19}{4} =$

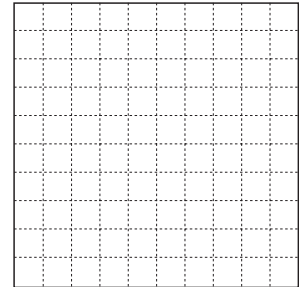

d) $0.17 =$ $0.30 =$ $2.1 =$ $6.5 =$

e) $1.2 =$ $3.80 =$ $12.05 =$ $0.75 =$

2

Fill in the missing numbers.

a) i) $\frac{1}{2}$ litre = ml ii) $\frac{1}{4}$ m = cm = mm

iii) $\frac{1}{5}$ kg = g iv) $\frac{1}{10}$ km = m

b) i) $\frac{3}{4}$ m = cm = mm ii) $\frac{2}{5}$ litre = ml

iii) $2\frac{1}{2}$ km = m iv) $\frac{3}{10}$ hour = minutes

c) i) 0.1 km = m ii) 0.2 litre = ml

iii) 0.3 m = cm = mm iv) 0.7 kg = g

d) i) 1.3 kg = g ii) 2.5 km = m

iii) 5.6 m = cm = mm iv) 6.25 litres = ml

3

Solve the problems in your exercise book.

a) A group of friends went on a 3-day trip. They covered 4 tenths of the journey on the first day and 0.3 of the journey on the second day. How much of the journey would they have to do on the 3rd day?

b) Lucy spent 1 and a half hours on her homework. She spent 0.4 of the time on mathematics. How long did she spend on mathematics? How long did she spend on other subjects?

c) Sam spent £72, which was 0.6 of his savings, on Christmas presents. How much had Sam saved? How much did he have left?

1

Write the sums in the table.

- a) $4 \times 100 + 5 \times 1 + 3 \times \frac{1}{10}$
- b) $7 \times 10 + 1 \times 1 + 4 \times \frac{1}{100}$
- c) $1 \times 100 + 3 \times \frac{1}{10} + 9 \times \frac{1}{100}$
- d) $9 \times \frac{1}{10} + 2 \times \frac{1}{100}$
- e) $7 \times 1 + 5 \times \frac{1}{100}$

H 100	T 10	U 1	t $\frac{1}{10}$	h $\frac{1}{100}$

2

Join up the decimal numbers to the matching points on the number line.

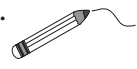

0.3 0.7 1.2 1.5 1.8 1.95

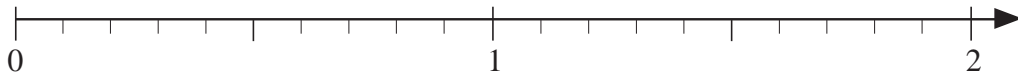

Write the decimal numbers as fractions below the number line.

3

Continue each sequence for 3 more terms. Write the rule you used.

- a) 0.1, 0.5, 0.9, 1.3, _____, _____, _____, Rule:
- b) $\frac{1}{8}$, $\frac{3}{8}$, $\frac{5}{8}$, $\frac{7}{8}$, _____, _____, _____, Rule:
- c) 8, 4, 2, 1, _____, _____, _____, Rule:
- d) 2.1, 1.9, 1.7, 1.5, _____, _____, _____, Rule:

4

Calculate the quantities and give the answer in the units asked for.

- a) $\frac{1}{2}$ of 35 m = m = m cm = cm
- b) 0.2 of 2 kg = kg = g
- c) $\frac{3}{4}$ of 10 litres = litres = litres cl = cl
- d) 0.25 of £22 = £ = £ p = p

5

Tim watched television for 2 and a half hours. He spent 0.6 of his time watching sport. For how long did he watch sport?

1

Add the quantities in the different units. Write the addition in the table.

a) $1.1 \text{ m} + 230 \text{ cm} + 8600 \text{ mm}$

In mm	In cm	In m	10 m	1 m	10cm	1 cm

b) $13.4 \text{ litres} + 1580 \text{ cl} + 2500 \text{ ml}$

In ml	In cl	In litres	10 ℓ	1 ℓ	10 cl	1 cl

2

Subtract the quantities in the different units. Write the subtraction in the table.

a) $4.73 \text{ m} - 210 \text{ cm}$

In mm	In cm	In m	1 m	10cm	1 cm

b) $18.6 \text{ litres} - 7900 \text{ ml}$

In ml	In cl	In litres	10 ℓ	1 ℓ	10 cl	1 cl

3

Calculate with fractions and decimals. Follow the example.

a) $4.9 = 4 + \frac{9}{10} = 4 + \frac{90}{100} = 4.90$

$10.23 = \quad = \quad =$

$+ 7.04 = \quad = \quad =$

$\underline{\quad} \quad \underline{\quad} \quad \underline{\quad} \quad \underline{\quad}$

$\underline{\quad} \quad \underline{\quad} \quad \underline{\quad} \quad \underline{\quad}$

b) Calculate $6.81 - 2.7$ in your exercise book in the same way.

1

Continue each sequence for the next 5 terms. Write down the rule you used.

a) 0.2, 0.4, 0.6, 0.8,,,,,,

b) 12.1, 11.8, 11.5, 11.2,,,,,,

c) 4.7, 5.9, 7.1, 8.3,,,,,,

d) 1, 1.1, 1.3, 1.6, 2, 2.5,,,,,,

Rule:

2

Calculate these quantities. Write the operation, then give the result in cm and m. Follow the example.

a) $\frac{1}{4}$ of 3 m = 300 cm \div 4 = 75 cm = 0.75 m

b) $\frac{3}{4}$ of 1 m = = =

c) $\frac{1}{5}$ of 2 m = = =

d) $\frac{2}{5}$ of 1 m = = =

e) the sum of b) and d) = = =

3

Estimate the result by rounding the numbers to the nearest whole number. Write the additions and subtractions in the tables.

a) $1.1 + 42.6 + 0.8$
 \approx

T	U	t

b) $62 + 6.2 + 0.62$
 \approx

T	U	t	h

c) $22.5 - 13.7$
 \approx

T	U	t

d) $32.8 - 13$
 \approx

T	U	t

e) $32 - 13.7$
 \approx

T	U	t

1

Calculate the sums and differences in different ways.

a) $6.8 + 4.7 =$

b) $2\frac{1}{10} + 3\frac{4}{10} =$

c) $5.2 - 1.6 =$

d) $6\frac{8}{10} - 1\frac{7}{10} =$

e) $4\frac{3}{10} + 11.8 =$

f) $7.2 - 3\frac{6}{10} =$

2

a)

		2	.	4
	1	0	.	3
+	8	7	.	2

b)

	4	2	.	1
		5	.	6
+		0	.	7

c)

1	2	3	.	6
	1	7	.	2
+	4	9	.	8

d)

6	0	0	0	.	8
	4	0	9	.	4
+	1	0	2	.	9

e)

1	0	.	5		
	4	.	6	5	
+	2	3	.	1	7

f)

1	3			
	0	.	9	
+	3	.	0	5

3

a)

	4	9	.	6
-	1	6	.	2

b)

	8	9	.	5
-	5	2	.	6

c)

4	2	.	1	5
-		8	.	9

d)

	8	5	.	4	
-	1	6	.	2	7

e)

6	5	.	6	4
-	3	9	.	3

f)

4	0			
-	3	.	5	6

4

Charlie went on a shopping spree. He spent £29 80 p on food, £37.60 on tools, £30.50 on things for his house and £38.50 on clothes.

a) How much did Charlie spend altogether? b) How much money did he have left if he had £200 to start with?

1

How much of each shape has been shaded? Join up the fractions to the matching diagrams.

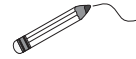

$\frac{1}{3}$ 0.5 $\frac{1}{4}$ $\frac{5}{9}$ 0.3 0.6 0.7

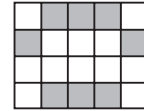
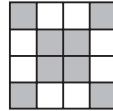

0.25 $\frac{1}{2}$ $\frac{3}{4}$ $\frac{3}{10}$ $\frac{8}{20}$ $\frac{4}{9}$ 0.4 $\frac{8}{16}$

2

Which number is more? How much more? Write the missing signs and differences.

a) 0.7 0.32

b) 5.8 7.1

c) 2.5 2.05

d) 0.50 0.5

e) 3.2 4

f) 0.6 0.66

3

Solve the problem in your exercise book.

The sides of a rectangular play area are 54.8 m wide and 23.6 m long.

How much fencing is needed to surround the play area if the gate is 1.8 m wide?

4

Which numbers can be written instead of the letters?

a) $a + 3.4 = 5.6$

$a =$

b) $b - 3.1 = 0$

$b =$

c) $c + 2.7 = 10$

$c =$

d) $7.8 + d = 12.3$

$d =$

e) $8.2 - e = 6.4$

$e =$

f) $f - 11.9 = 6.3$

$f =$

g) $g + g + 5.4 = 10$

$g =$

h) $0.4 + h = 0.8 - h$

$h =$

i) $\frac{2}{5} + i = 1.3$

$i =$

j) $j - 0.8 = 1\frac{5}{10}$

$j =$

k) $\frac{3}{4} - k = 0.07$

$k =$

1

Which is more? How much more? Fill in the missing signs and differences.

a) $0.3 \square \frac{1}{2}$ b) $\frac{3}{4} \square 0.75$ c) $\frac{3}{5} \square 0.2$
 $\square = \square$ \square $\square = \square$

2

Fill in the missing numbers. Follow the example.

a) i) $3 \text{ mm} = \frac{3}{10} \text{ cm} = 0.3 \text{ cm}$ ii) $6 \text{ mm} = \square \text{ cm} = \square \text{ cm}$
 b) i) $5 \text{ cm} = \square \text{ m} = \square \text{ m}$ ii) $9 \text{ cm} = \square \text{ m} = \square \text{ m}$
 c) i) $76 \text{ cm} = \square \text{ m} = \square \text{ m}$ ii) $12 \text{ m} = \square \text{ km} = \square \text{ km}$

3

Which numbers can be written instead of the letters?

a) $a + 2.3 = 3.7$ b) $b - 4.6 = 8$ c) $6.1 - c = 4$
 $a = \square$ $b = \square$ $c = \square$
 d) $\frac{3}{5} + d = 1\frac{1}{5}$ e) $e - \frac{1}{4} = 2.6$ f) $4.3 - f = 3\frac{1}{2}$
 $d = \square$ $e = \square$ $f = \square$

4

Solve the problem in your exercise book. Write only the answer here.





On Monday Paul spent £5.27, on Tuesday he spent £3.59, on Wednesday he spent £4.57, on Thursday he spent £3.12 and on Friday he spent £2.27.

- a) How much did Paul spend altogether?
- b) How much did he have left if he had £20 to start with?

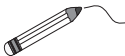
5

Join the numbers to the matching diagrams.

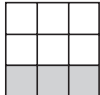
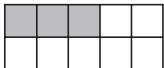
$\frac{3}{9}$ 0.3 $\frac{1}{4}$ $\frac{4}{10}$ 0.4 $\frac{2}{5}$ 

$\frac{2}{12}$ 0.25 $\frac{2}{8}$ $\frac{1}{3}$ $\frac{1}{6}$ $\frac{3}{10}$

1

Write a plan, estimate, calculate and check in your exercise book. Write the answer here.

- a) Helen spent £8.40, Jane spent £3.90 and Lisa spent £5.20.
How much did they spend altogether?
.....
- b) Frank and Barry each dug up $\frac{2}{5}$ of the vegetable plot.
i) What part of the vegetable plot did they dig up altogether?
.....
ii) What part did they still have to dig?
.....
- c) Polly bought 1.5 kg of apples and $\frac{5}{10}$ kg less of bananas.
i) How many kg of bananas did she buy?
ii) How much fruit did she buy altogether?

2

Draw a diagram to help you solve the problem.

Kate wants to cut a 2.4 m length of ribbon into two pieces, so that one piece is twice as long as the other piece. What will be the length of each piece?

Answer:

3

Divide up the shapes into 4 **congruent** parts so that the sum of the numbers in each part is 2.

a)

$\frac{2}{10}$	$\frac{2}{10}$			$\frac{4}{10}$	$\frac{4}{10}$
$\frac{3}{10}$	$\frac{3}{10}$			$\frac{3}{10}$	$\frac{3}{10}$
$\frac{5}{10}$	$\frac{1}{10}$	$\frac{6}{10}$	0	$\frac{4}{10}$	$\frac{1}{10}$
$\frac{5}{10}$	$\frac{1}{10}$	$\frac{6}{10}$	$\frac{2}{10}$	$\frac{4}{10}$	$\frac{3}{10}$
		$\frac{3}{10}$	$\frac{5}{10}$		
		$\frac{3}{10}$	$\frac{5}{10}$		

b)

0.3	0.3	0.3	0.3
0.2	0.3	0.4	0.4
0.5	0.5	0.4	0.1
0.3	0.2	0.2	0.4
0.6	0.3	0.2	0.7
0.2	0.5	0.1	0.3

1

Write a plan, estimate, calculate and check the result in your exercise books.
Write the answer in a sentence here.

- a) If I were to give you £6.40, you would have £25.80.
How much do you have?

Answer:

- b) After gathering another $1\frac{2}{5}$ kg of mushrooms, I have $2\frac{1}{5}$ kg of mushrooms altogether. How many kg of mushrooms did I have at first?

Answer:

- c) What length is the perimeter of this rectangle?

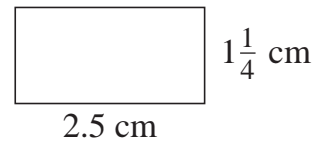

Answer:

2

Solve the problems.

- a) Divide 20.3 kg into three parts so that the lightest part is half the weight of the middle-sized part and the middle-sized part is half the weight of the heaviest part.



Lightest part:

Middle-sized part:

Heaviest part:

- b) Which is more and how much more: $\frac{2}{3}$ of 1200 litres or $\frac{4}{5}$ of 1000 litres?
Write it as an inequality.

3

Fill in the missing numbers.

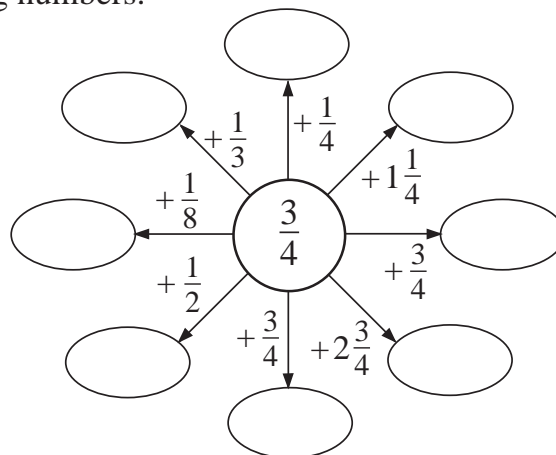

1

Solve the problems in your exercise book. Write the answers here.

- a) Sarah cut 2 m 10 cm from a 3.3 m piece of lace to trim a cushion.
How much lace did she have left?

Answer:

- b) Jim bought 5 litres of plant food. He used 2 litres 70 cl on his vegetables and 1.2 litres on the other plants in his garden.
How much plant food did he have left?

Answer:

2

How can the butterfly get to the flower? Calculate the length of the possible routes.

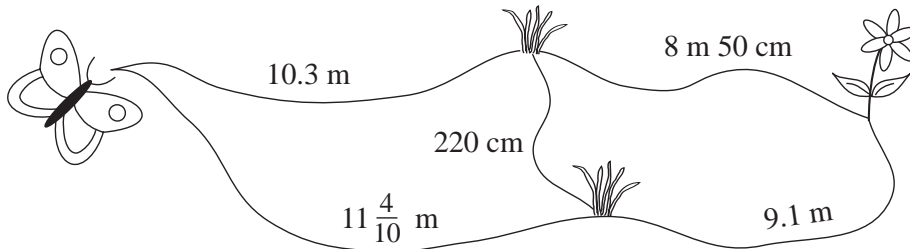

.....

.....

.....

.....

3

Three boys are giving each other clues about their heights. How tall is each boy?

Adam says, "My height is two thirds of 180 cm." A:

Billy says, "My height is eight tenths of 160 cm." B:

Chris says, "Three fifths of my height is 72 cm." C:

4

Work out the rule and fill in the missing numbers.

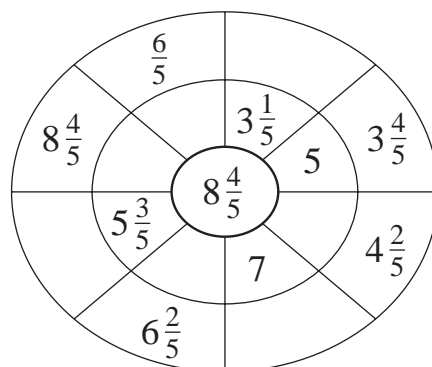

1

Change the quantities.

- a) $40 \text{ cm} = \square \text{ mm}$ b) $30 \text{ mm} = \square \text{ cm}$
 $508 \text{ cm} = \square \text{ mm}$ $8060 \text{ mm} = \square \text{ cm} = \square \text{ m } \square \text{ cm}$
 $70 \text{ m} = \square \text{ cm}$ $7800 \text{ cm} = \square \text{ m}$
 $68 \text{ m} = \square \text{ cm}$ $520 \text{ cm} = \square \text{ m } \square \text{ cm} = \square \text{ mm}$

2

Change the quantities.

- a) $73 \text{ litres} = \square \text{ cl}$ b) $40 \text{ ml} = \square \text{ cl}$
 $57 \text{ cl} = \square \text{ ml}$ $93 \text{ ml} = \square \text{ cl } \square \text{ ml} = \square \text{ cl}$
 $6.2 \text{ kg} = \square \text{ g}$ $1800 \text{ g} = \square \text{ kg } \square \text{ g} = \square \text{ kg}$
 $5.8 \text{ litres} = \square \text{ cl}$ $450 \text{ cl} = \square \text{ litres } \square \text{ cl} = \square \text{ litres}$

3

Fill in the missing numbers.

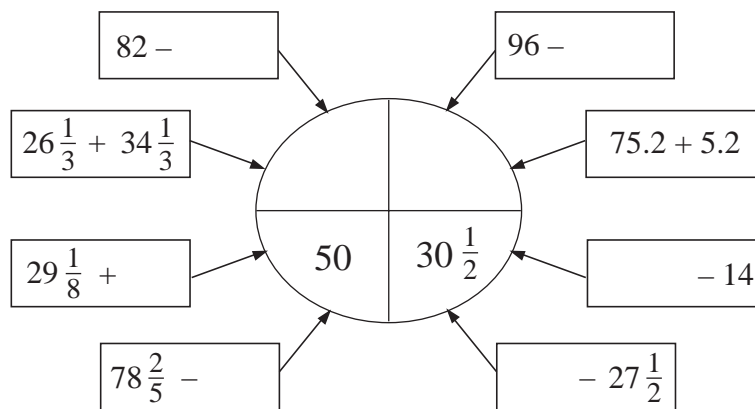

4

Work out the rule and fill in the missing numbers.

- a)

22.7	14.8	11.2	8.7
7.9		2.5	

 b)

87.9	55.5	33.3	12.1
	22.2	21.2	

5

Solve the problem in your exercise book.

Uncle Jim earned £2400 in February. He spent one fifth of it on food, one sixth on bills and one quarter on his garden. How much did he have left?

1

Plan, estimate, calculate and check in your exercise book. Write the answer here.

- a) Alice spent £3.27, Barry spent £4.17 and Chris spent £5.82 on their meals. How much was the bill altogether?
- b) Dan mowed $\frac{3}{10}$ of the grass and Erica mowed $\frac{1}{5}$ of it.
- i) What fraction of the grass did they mow altogether?
- ii) What fraction of the grass still has to be cut?
- c) Jill bought 2.5 kg of apples and half a kg more of pears.
- i) How many kg of pears did she buy?
- ii) How much fruit did she buy altogether?

2

Fill in the missing numbers.

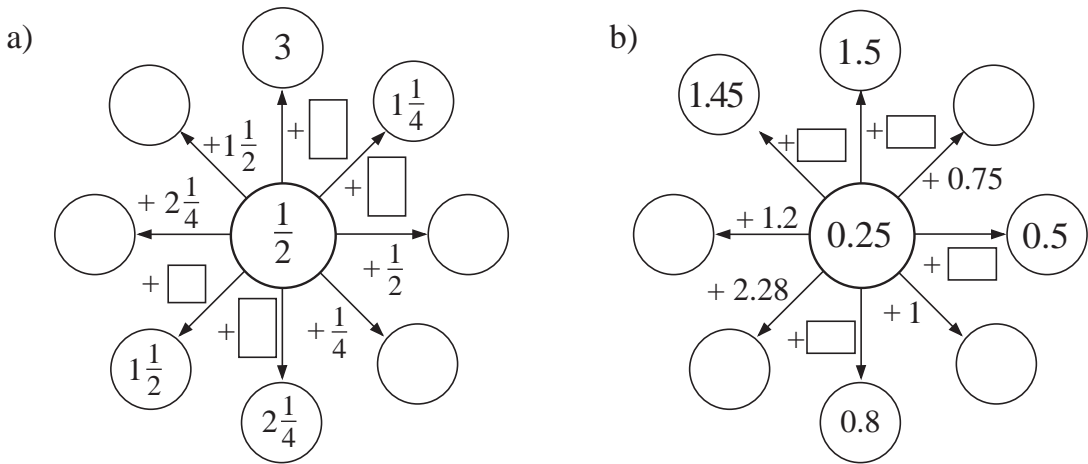

3

Which quantity is greater? Fill in the missing signs.

- a) $\frac{3}{10}$ m 54 cm b) 0.9 kg 90 g c) $\frac{1}{6}$ hour 30 min
- d) £150 20 p £150.2 e) $5\frac{7}{100}$ litres 5 litres 700 ml
- f) $4\frac{1}{2}$ weeks 29 days g) 84.3 cm 843 mm 8.43 m

4

Draw a digram to help you solve the problem.

Jack wants to cut a 1.2 m length of wood into two pieces so that one piece is three times as long as the other piece.

What will be the length of each piece? Give your answer in cm

Answer:

1

Measure, count or calculate the perimeter and area of the polygons.

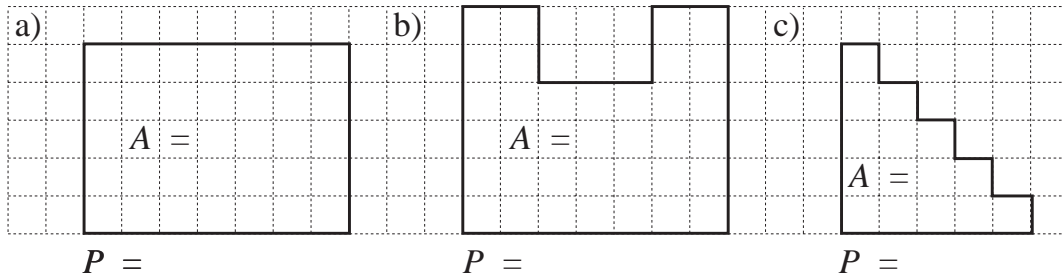

2

The sides of a triangular lake are 2400 m, 1350 m and 2130 m long. What is the length of its perimeter?

Plan:

Answer:

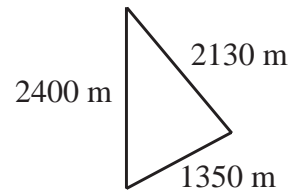

3

Write a plan, estimate, calculate and write the answer.

a) A practice book is 29.7 cm long and 20.8 cm wide. How long is its perimeter?

Plan:

C:



E:

Answer:

b) George's room is four and two fifths metres long and three and a half metres wide. How long is its perimeter?

Plan:

C:

E:

Answer:

4

Calculate the area and the perimeter of this rectangle.

$P =$

$A =$

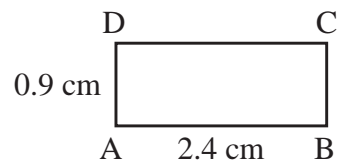

5

How can the fishing lake be enlarged to twice its area without moving the 4 oak trees?

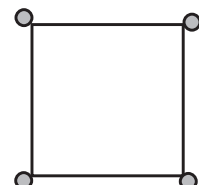

1

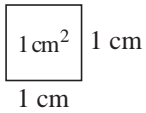

The unit of area is 1 cm^2 . The unit of length is 1 cm .

Continue the sequence and complete the table.

Write the rule in different ways.

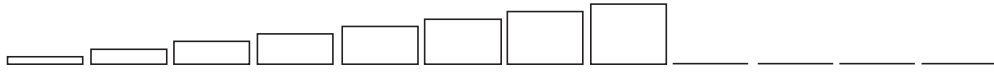

<i>a</i>	1	1	1	1	1	1	1	1	1	1	1	1
<i>b</i>	0.1	0.2	0.3	0.4	0.5	0.6	0.7	0.8	0.9			
<i>P</i>	2.2	2.4										
<i>A</i>	0.1	0.2										

P = *a* = *b* = *A* =

2

Ten pupils measured their heights and wrote them down in various ways.

A = 1.3 m, B = 1 m 35 cm, C = 134 cm, D = 1350 mm, E = 1 m 340 mm

F = $1 \frac{34}{100}$ m, G = 140 cm, H = 1 m 36 cm, I = 1 m 400 mm, J = 1.34 m

a) Show the data in this **tally chart**.

130	131	132	133	134	135	136	137	138	139	140	cm

b) Write the data in **decreasing** order.

c) Which height is the most frequent? This is the **mode**.

d) Which are the middle data?

3

a)

4	1	7		3	8	1	8	3	9	6	0	9	2	2	3	4	5					
+		6	6	+	4	2	0	6	-	5	0	4	-		5	2	+	7	6	5	4	

b)

	7	8	5	2	9	3	6	4	3	5	0	8	2	7	8	3	4				
+	2	0	6	+	7	5	4	-	2	0	8	-	4	3	5	-	1	8	5	6	

4

a)

2	1	3	×	3	2	0	2	1	×	4	3	6	4	5	5	5
												×	7		×	6

b)

4	8	4	8	3	9	0	3	6	6	3	6	4	2	7	8	8	8

1

Write true statements about each diagram in your exercise book.

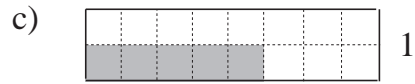
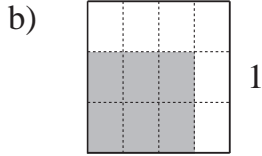
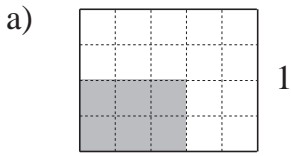

2

Fill in the missing numbers.

a)
$$\begin{array}{r} \underline{\quad\quad\quad} \\ 9000 \\ 4000 + \boxed{\quad\quad\quad} \\ 3900 + \boxed{\quad\quad\quad} \\ \boxed{\quad\quad\quad} + 850 \\ \boxed{\quad\quad\quad} + 67 \\ 1 + \boxed{\quad\quad\quad} \end{array}$$

b)
$$\begin{array}{r} \underline{\quad\quad\quad} \\ 12 \\ 5.6 + \boxed{\quad\quad\quad} \\ 12 + \boxed{\quad\quad\quad} \\ 3\frac{1}{5} + \boxed{\quad\quad\quad} \\ \boxed{\quad\quad\quad} + 11\frac{2}{3} \end{array}$$

c)
$$\begin{array}{r} \underline{\quad\quad\quad} \\ 16 \\ 8 \times \boxed{\quad\quad\quad} \\ 4 \times \boxed{\quad\quad\quad} \\ \boxed{\quad\quad\quad} \times 1 \\ \boxed{\quad\quad\quad} \div 3 \\ 0.5 \times \boxed{\quad\quad\quad} \end{array}$$

3

Fill in the next nearest:

a) tens	b) units	c) tenths
$\boxed{\quad\quad} < 5420 < \boxed{\quad\quad}$	$\boxed{\quad\quad} < 5420 < \boxed{\quad\quad}$	$\boxed{\quad\quad} < 5420 < \boxed{\quad\quad}$
$\boxed{\quad\quad} < 657 < \boxed{\quad\quad}$	$\boxed{\quad\quad} < 657 < \boxed{\quad\quad}$	$\boxed{\quad\quad} < 657 < \boxed{\quad\quad}$
$\boxed{\quad\quad} < 43.2 < \boxed{\quad\quad}$	$\boxed{\quad\quad} < 43.2 < \boxed{\quad\quad}$	$\boxed{\quad\quad} < 43.2 < \boxed{\quad\quad}$
$\boxed{\quad\quad} < 103\frac{7}{8} < \boxed{\quad\quad}$	$\boxed{\quad\quad} < 103\frac{7}{8} < \boxed{\quad\quad}$	$\boxed{\quad\quad} < 2.93 < \boxed{\quad\quad}$

4

These were the fruit that 20 children in a class brought for their lunch.

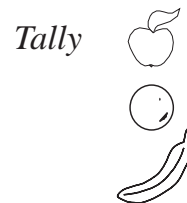
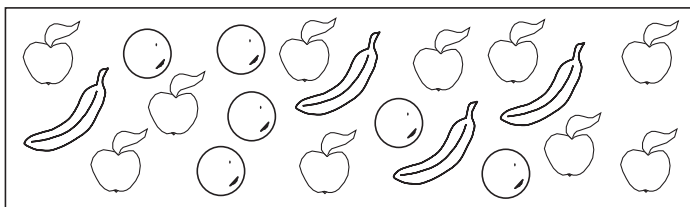

- a) What fraction of the fruit were apples?
- b) What fraction of the fruit were oranges?
- c) What fraction of the fruit were bananas?
- d) Which was the most popular fruit?

1

Imagine these cubes built from unit cubes.
Fill in the missing numbers.

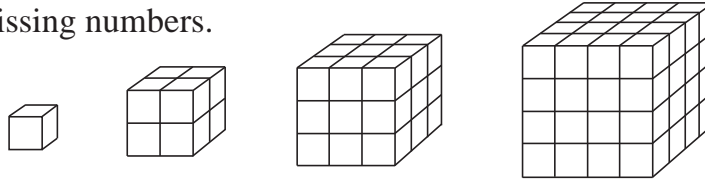

Length of 1 edge \dashv	1	2	3	4	5	6
Area of cube \square						
Volume of cube \square						

2

Imagine the cuboid which has this net. Calculate its surface area and volume.
Complete the table.

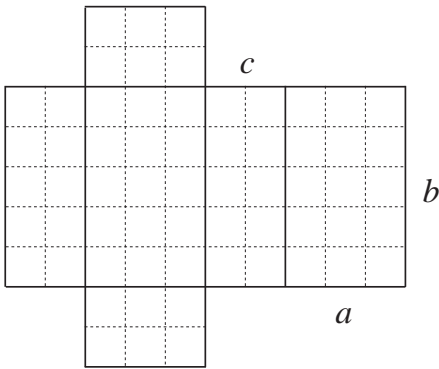

$a \dashv$	$b \dashv$	$c \dashv$	$A \square$	$V \square$

3

The **pie chart** shows which part of the class chose which game to play.

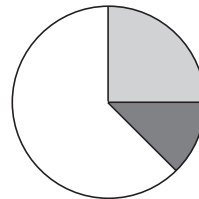

- \circ Basketball
- light grey circle Football
- dark grey circle Tennis

- a) Write each part as a fraction. B: F: T:
- b) How many children chose each game if there were 24 pupils in the class? B: F: T:

4

Solve the equations.

- a) i) $3 + \square = 11$ ii) $\square + 820 = 1000$ iii) $\frac{3}{7} + \square = \frac{6}{7}$
 iv) $\square + \frac{2}{9} = 1$ v) $2.3 + \square = 4$ vi) $\square + 0.6 = 1$
- b) i) $7 - \square = 2$ ii) $\square - 820 = 1000$ iii) $\frac{8}{9} - \square = \frac{2}{9}$
 iv) $\square - \frac{1}{3} = \frac{1}{3}$ v) $4.3 - \square = 3.1$ vi) $\square - 0.6 = 0.4$

1

Calculate the area and perimeter of each polygon.

a) P =

c)

2

a) Calculate the area and perimeter of this rectangle.

$P = \dots\dots\dots$

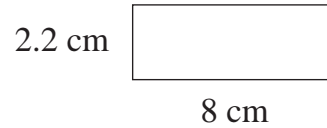

$A = \dots\dots\dots$

b) What is the length of the side of a square which has a perimeter equal to this rectangle? $\dots\dots\dots$

3

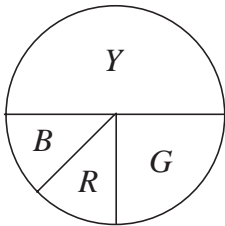

The **pie chart** shows the favourite colours of the 32 pupils in a class.

a) What fraction of the class chose each colour?

Red: Blue: Yellow: Green:

b) How many pupils chose each colour?

R: $\dots\dots\dots$ B: $\dots\dots\dots$ Y: $\dots\dots\dots$ G: $\dots\dots\dots$

4

Solve the equations.

- a) i) $5 + \square = 6.5$ ii) $\square + 3.9 = 5.7$ iii) $\square + \frac{1}{4} = \frac{5}{4}$
 iv) $\square + \frac{2}{7} = 1$ v) $4.7 + \square = 6.3$ vi) $\square + 0.7 = 1$
- b) i) $6 - \square = 4.5$ ii) $\square - 2.3 = 4.9$ iii) $\frac{5}{7} - \square = \frac{2}{7}$
 iv) $\square - \frac{1}{5} = \frac{4}{5}$ v) $4.7 - \square = 3.9$ vi) $\square - 0.3 = 0.7$

5

Join up the equal values.

- $1 - 0.2$ 2.3 $\frac{6}{10}$ 1 and a half
 $2 \frac{3}{10}$ $\frac{4}{5}$ 1.5 0.75 $\frac{3}{4}$ 0.6

