

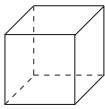

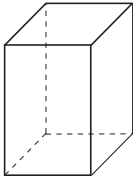





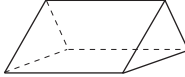
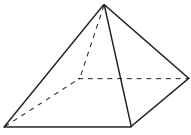

1

Complete the table for these **solids**.

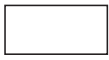

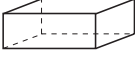

					
Number of faces					
Number of vertices					
Number of edges					

2

Which shape belongs in which box? Write the numbers in the correct boxes.

1  2  3  4  5  6  7  8  9  10 



Plane shapes Rectangles Solids Quadrilaterals

3

These **plane** shapes were cut out from coloured paper.

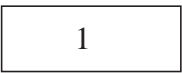
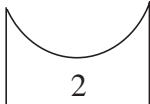
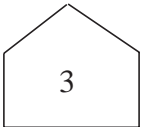
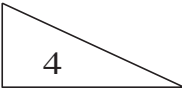
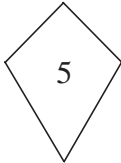
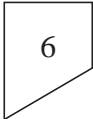
1  2  3  4  5  6 

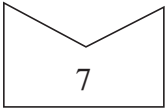
7  8  9  10  11  12 

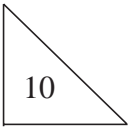
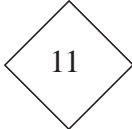
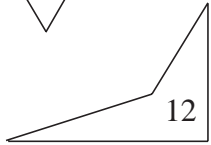
List the numbers of the shapes which are:

- a) quadrilaterals:
- b) rectangles:
- c) squares:

4

How many different **cuboids** can you build from 12 unit cubes?

- a) Fill in the table.
- b) Circle the cuboids which have at least one square face.

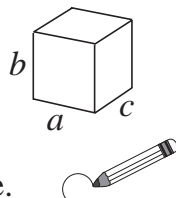

	Cuboids			
	1	2	3	4
Edge a =				
Edge b =				
Edge c =				

1

- a) Draw over in the same colour the sets of lines which are **parallel**. Use different colours for different sets.
- b) Colour the square at all the corners which are right angles.

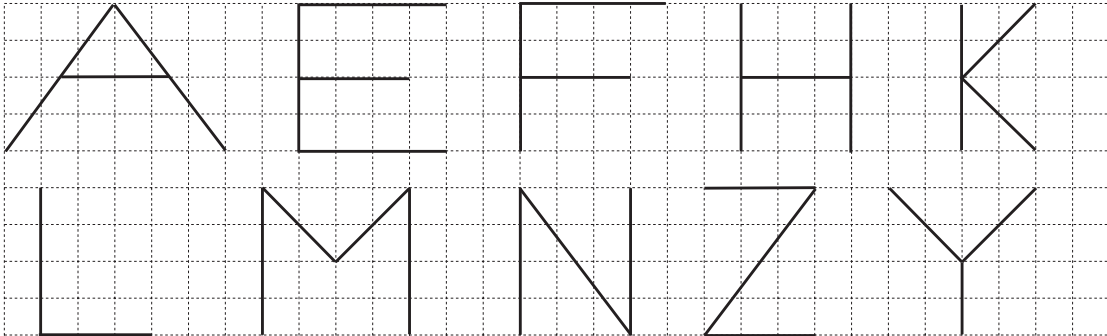

2

This is part of the track from a model railway.

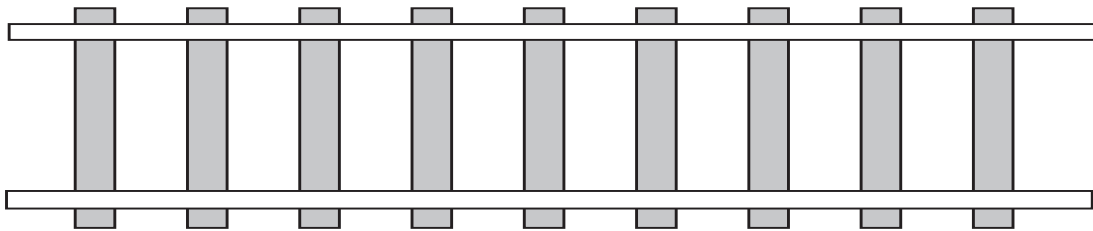

Measure the distance between the two **horizontal** rails.



3

Draw over in the same colour the sets of lines which are **parallel**. Use a different colour for each set. Colour the squares at corners which are **right angles**.

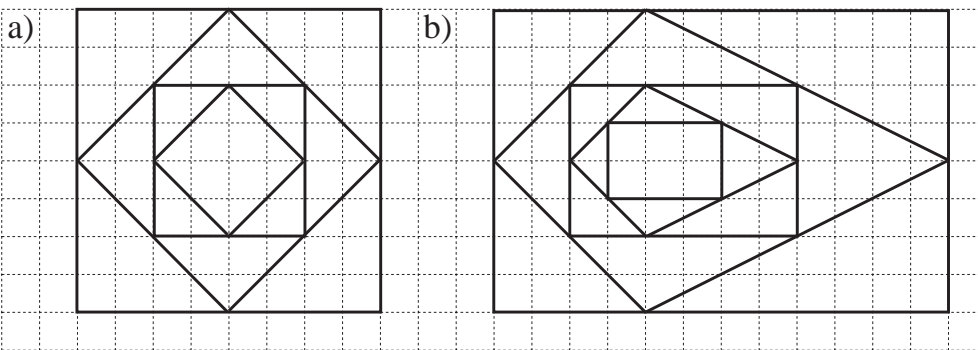

4

Complete the drawing to make **rectangles**.

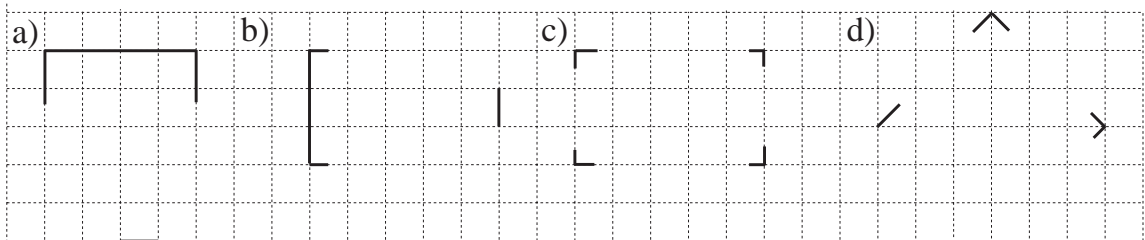

1

Piggy bought different kinds of cakes for a party he was arranging.

- a) Piggy wanted to taste each cake right away.
 What part of these cakes did Piggy eat before the party?

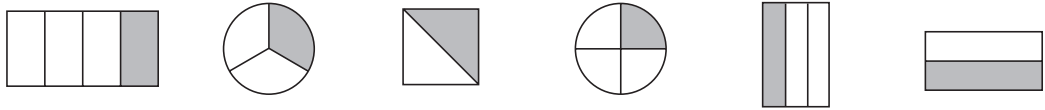
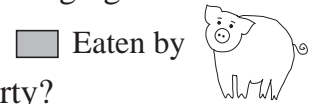

- b) After the party, Piggy checked on what had been left.
 Colour the parts of the cakes he found.

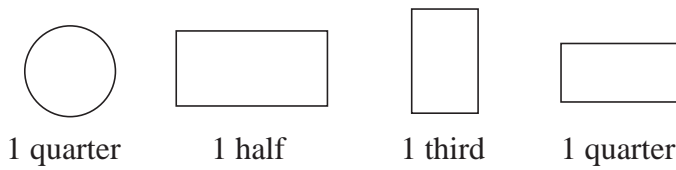

2

Colour one half of each shape in *red* and the other half in *blue*.

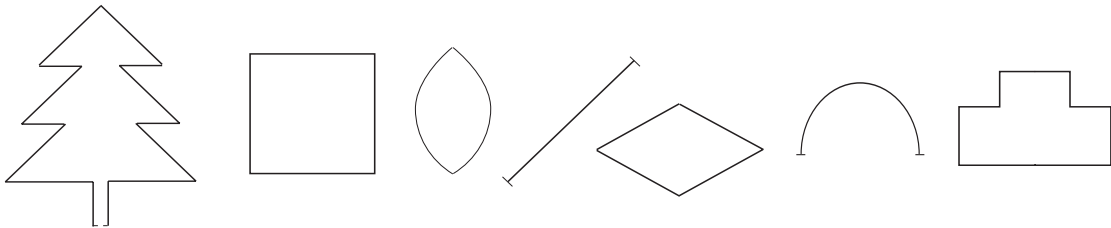

3

Each drawing is only half of the picture. Complete the whole drawing.

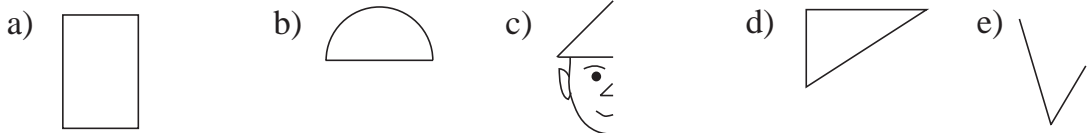

4

- a) Tom had a length of wire which was 110 cm long.
 He used half of it to make a model. What length of wire did he have left?

Answer:

- b) Last month Lucy had £30 in her savings bank. Today, this amount is only half of what she has saved. How much money does Lucy have now?

Answer:

1

Colour a quarter of each shape.

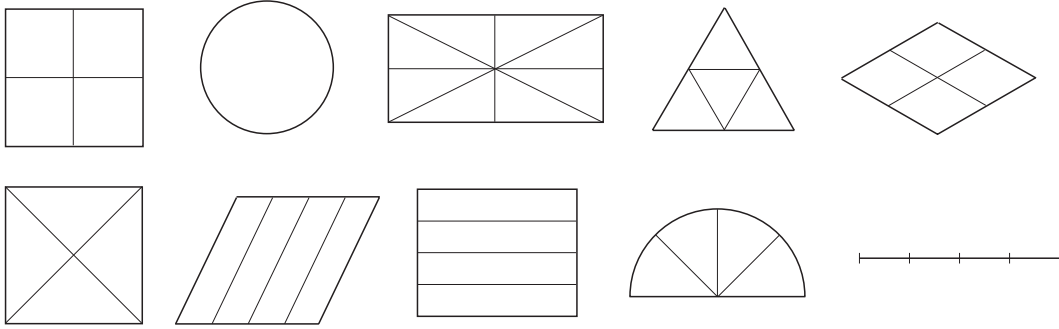

2

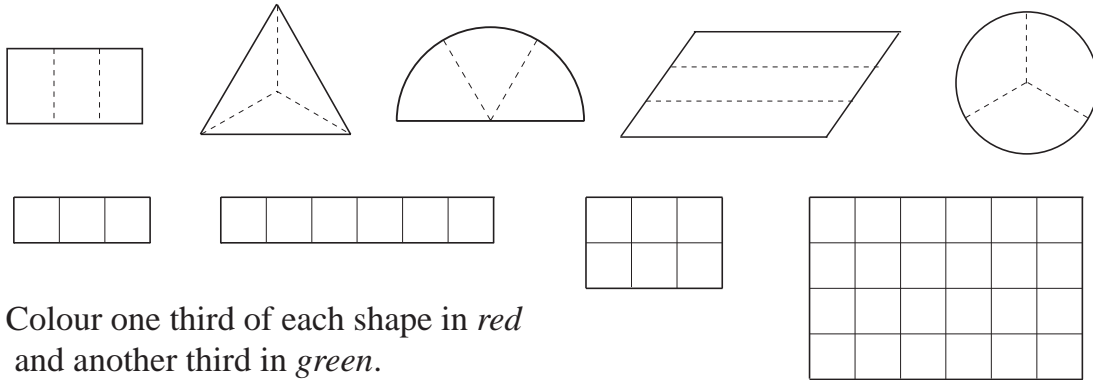

Colour one third of each shape in *red* and another third in *green*.

3

a) Each drawing is 1 third of a unit. Complete it to make the whole unit.

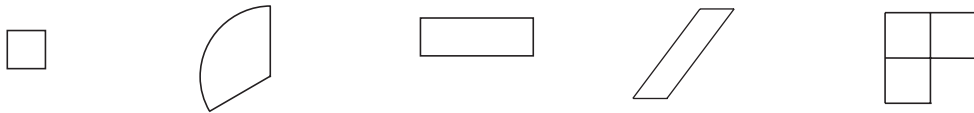

b) Each drawing is 1 quarter of a shape. Complete it to make the whole shape.

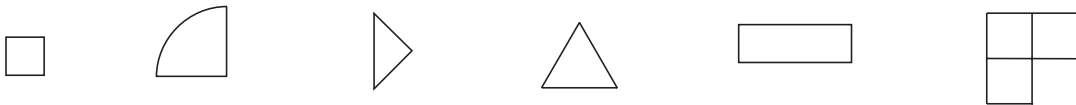

4

Join up the labels to the corresponding shapes.

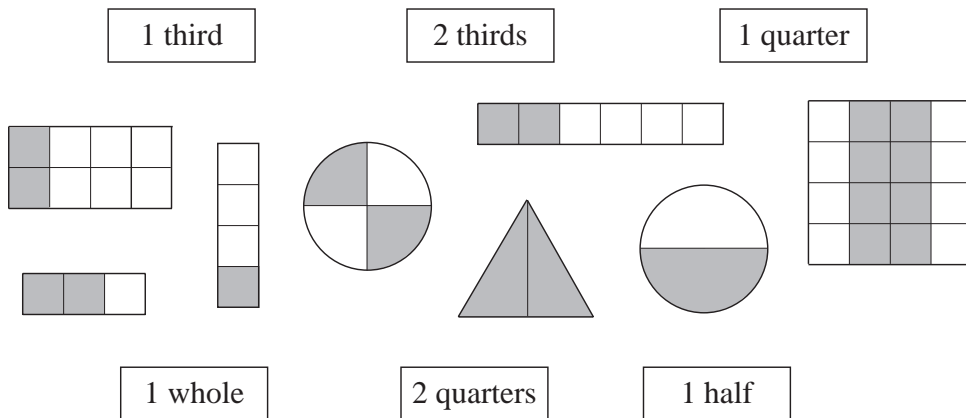
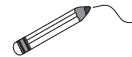

1

Fill in the missing numbers. Write down the rule.

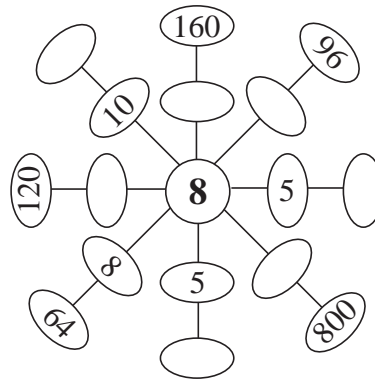
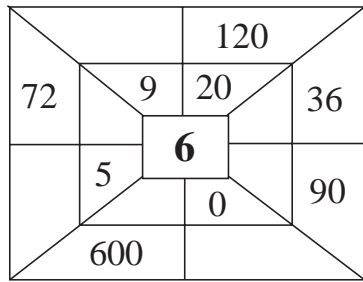

Rule:

2

Round these numbers to the next nearest whole ten.

- a) 33 ≈ 57 ≈ 96 ≈
 b) 108 ≈ 203 ≈ 399 ≈
 c) 556 ≈ 411 ≈ 666 ≈

3

Write the Roman numerals below these numbers.

- a) 152 b) 74 c) 300 d) 99 e) 108

4

Practise calculation.

- a) $10 \times \square = 300$ b) $\square \times 17 = 0$ c) $\square \times 4 = 60$
 $9 \times \square = 270$ $150 \div \square = 15$ $167 \div \square = 167$
 $\square \times 5 = 500$ $90 \div \square = 45$ $\square \div 2 = 50$
 $\square \times 8 = 240$ $\square \div 5 = 200$ $\square \div 19 = 0$
 $\square \times 11 = 110$ $\square \div 6 = 110$ $\square \div 50 = 5$

5

a) How many hours and minutes have passed in an evening from:

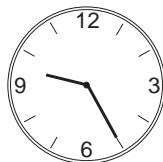

to

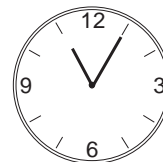

hours
 minutes

b) How many more minutes will it then be until midnight?

minutes

1

Colour the correct number of marbles. Write a division about each picture.

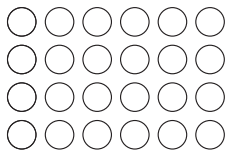

1 third

$24 \div 3 = \square$

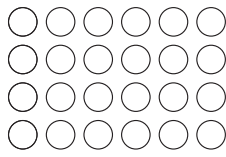

1 quarter

.....

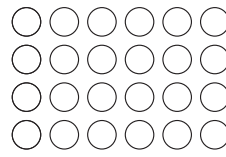

1 sixth

.....

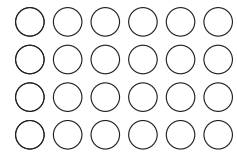

1 eighth

.....

2

How many hours and minutes do the hands on the clock show?



hours

minutes



hours

minutes

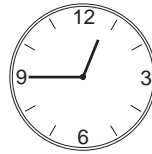

hours

minutes

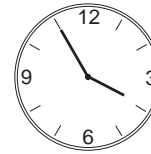

hours

minutes

3

a) How many minutes does the minute hand on the clock show when it is pointing to these numbers? Complete the table.

Minute hand points to:	12	1	2	3	4	5	6	7	8	9	10	11
Minutes shown												

b) Shade the clocks to show how far the minute hand has gone. Join up the clocks which are the same.

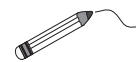

5 minutes

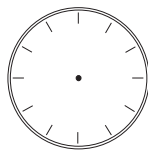

15 minutes

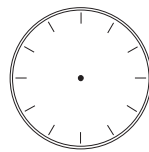

half an hour

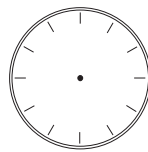

3 quarters of an hour

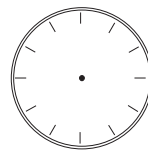

30 minutes

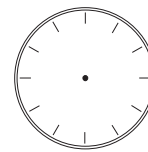

45 minutes

4

Compare the two sides. Write the correct sign between them. (=, <, >)

a) half an hour 35 minutes b) 15 minutes a quarter of an hour

c) 50 minutes 3 quarters of an hour d) 1 hour 60 minutes

e) a quarter of an hour + 5 minutes half an hour - 5 minutes

f) 20 minutes + half an hour a quarter of an hour + half an hour

1

The clock is set at 12 noon.



Draw where the hands of the clock will be after these amounts of time:

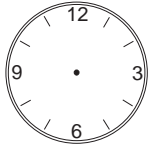

12 h 15 min

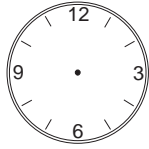

12 h 30 min

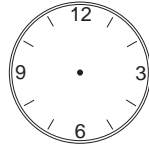

quarter of an hour

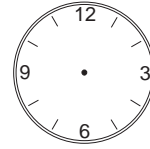

12 h 20 min

2

Join up the equal quantities.

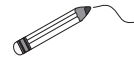

half an hour

a quarter of an hour

3 quarters of an hour

2 thirds of an hour

15 minutes

45 minutes

30 minutes

40 minutes

1 third of an hour

20 minutes

3

Complete the open sentences so that they are correct.

a) 3 quarters of an hour + hour = 1 hour.

b) 30 minutes + hour = 1 hour.

c) 20 minutes + half an hour + minutes = 1 hour.

d) A quarter of an hour + a third of an hour + minutes = 1 hour.

4

If the statement is correct, write a ✓ in the box. If not, write a ✗ and correct the mistake.

a) 1 hour = 60 minutes

b) Half an hour = 20 minutes

c) Half an hour = 2 quarters of an hour

d) 20 minutes = 2 thirds of an hour

e) 3 quarters of an hour = 45 minutes

f) 2 thirds of an hour = 1 quarter of an hour + 5 minutes

g) 2 quarters of an hour = 1 quarter of an hour + 15 minutes

1

Colour the odd one out. Write the reason for your choice.

120 minutes	1 hour + half an hour + 25 minutes	60 minutes + 3 quarters of an hour + 1 quarter of an hour	3 quarters of an hour + 1 third of an hour + 55 minutes
1 twelfth of a day			

Reason:

2

Write the amounts of time in **increasing** order.

35 minutes	10 minutes	3 quarters of an hour	half a day
	1 third of an hour	1 quarter of an hour	

.....

3

Sparrow and *Trout* were arguing over the times in a day. Who is correct? Tick the correct answer and cross out the wrong one.

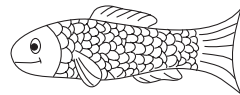

12 hours

half a day

30 hours

14 hours

2 quarters of a day

12 hours

4 hours

1 sixth of a day

4 hours

45 minutes

2 half hours

60 minutes

15 minutes

a quarter of an hour

20 minutes

40 minutes

2 thirds of an hour

45 minutes

2 hours

1 eighth of a day

3 hours

9 hours

2 sixths of a day

8 hours

18 minutes

3 tenths of an hour

20 minutes

1

Complete the open sentences so that they are correct.

- a) 1 fifth of an hour + hour = 1 hour.
- b) 40 minutes + hour = 1 hour.
- c) 10 minutes + half an hour + minutes = 1 hour.
- d) 3 quarters of an hour + 1 sixth of an hour + minutes = 1 hour.
- e) 2 thirds of an hour + minutes = 1 hour.
- f) minutes + 3 quarters of an hour = 1 hour.
- g) 2 thirds of an hour + hour = 1 hour.

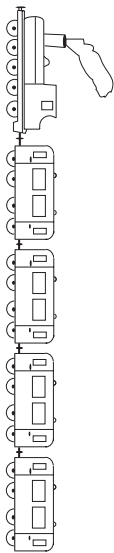
2

A train runs at different times of the day between 2 stations.
Complete the table.

Departs from Station A at:	Arrives at Station B at:	Journey time:	
6:53	11:30	h	min
10:25	13:10	h	min
17:05	20:56		
21:30	00:45		
00:36	04:35		

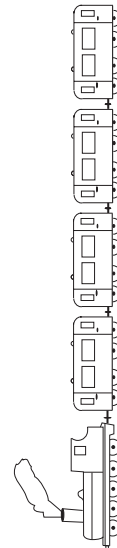
**3**

Practise division. Check with multiplication.

- a) $31 \div 5 = \square$ remainder \square
Check
- b) $87 \div 9 = \square$ remainder \square
Check
- c) $48 \div 7 = \square$ remainder \square
Check
- d) $106 \div 10 = \square$ remainder \square
Check
- e) $98 \div 3 = \square$ remainder \square
Check
- f) $85 \div 60 = \square$ remainder \square
Check

1

If this is 1 unit:  → 1 unit

what is the value of each shaded part?

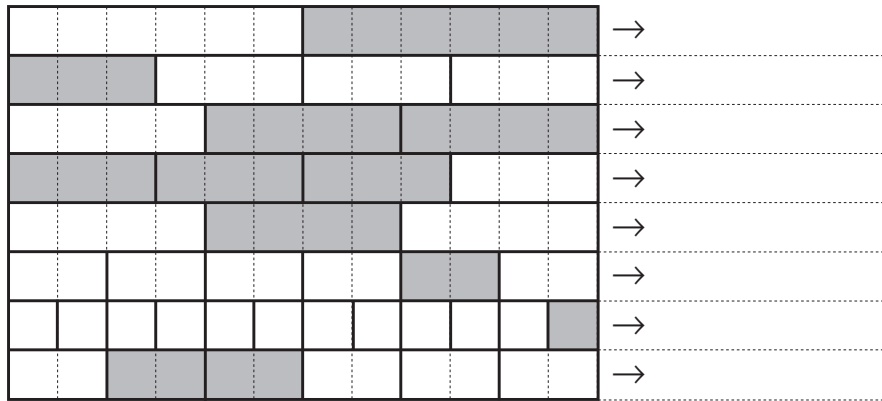

2

This is my garden.

10 m

I have already dug up part of it.

4 m

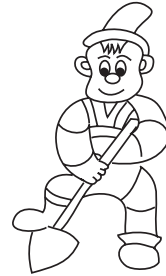
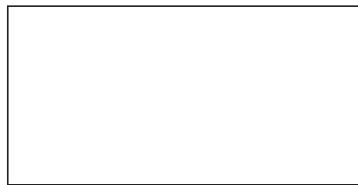

How much of the garden do I still have to dig?
Complete the table.

Part already dug	1 fifth				1 half	2 tenths		4 fifths
Part remaining		1 quarter	3 quarters	2 fifths			4 tenths	

3

I have already drunk 3 quarters of a 2 litre bottle of lemonade.

- a) What part of the lemonade is left?
- b) How many cl of the lemonade is left?
- c) How many cl of lemonade have I drunk?

4

Write a context for the plan.
Solve it.

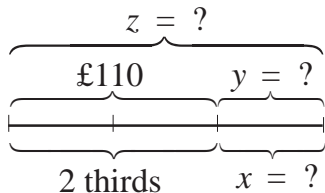

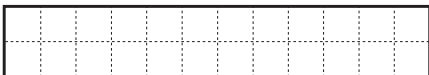

1

Complete the drawings.

If this is : 1 whole → 

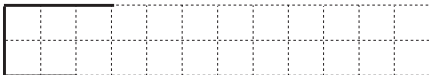
then this is:

1 half → 

1 sixth → 

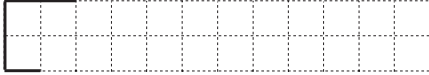
1 eighth → 

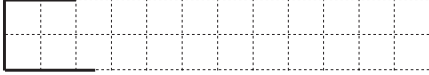
1 third → 

2

Five children are running in a 240 m race. At this moment in time:

- Tom has run 4 sixths of the distance.
- Zoe has run 2 thirds of the distance.
- Carol has run 3 quarters of the distance.
- Jamie has run 3 sixths of the distance.
- Sue has run half way.

Mark where each child is on the running track.

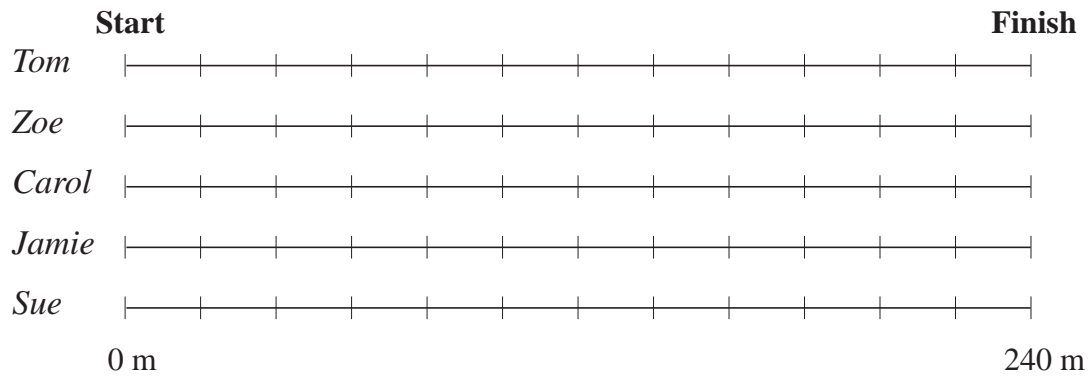

3

Gerry spent £140 on his holiday. Joe spent 1 seventh more than Gerry.

a) How much money did Joe spend on his holiday?

Answer:

b) How much money did Gerry and Joe spend altogether?

Answer:

1

Each number is the **sum** of the two numbers directly below it.
Fill in the missing numbers.

a)

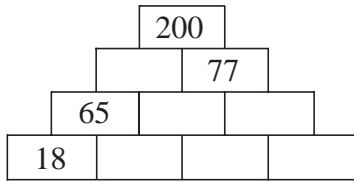

b)

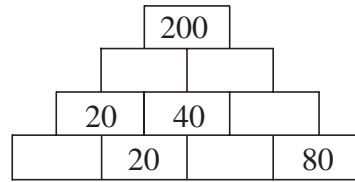

2

Each number is the **product** of the two numbers directly below it.
Fill in the missing numbers.

a)

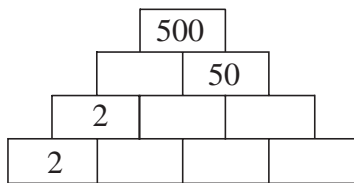

b)

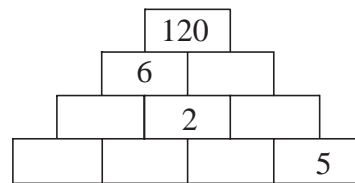

3

In a school, each lesson starts on the hour and lasts for 45 minutes.

- a) What part of an hour is:
- i) each lesson
 - ii) each break?
- b) The lessons start at 09:00 and lunch is at 13:00.
How many lessons are there during the morning?
- c) How many hours and minutes do pupils spend:
- i) in lessons
 - ii) in breaks?

4

Fill in the missing items.

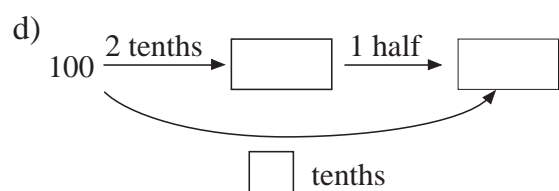
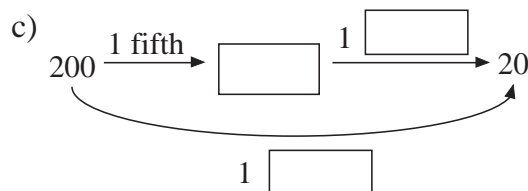
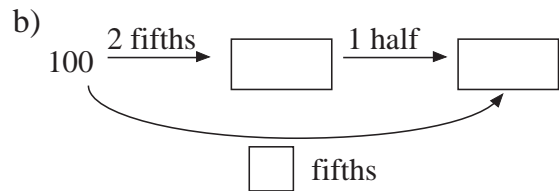
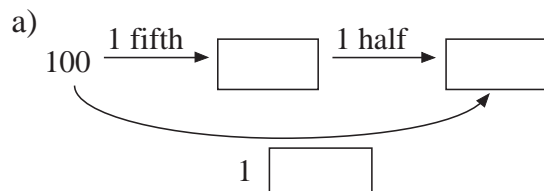

1 Complete each given part to 2 whole units.

a) 1 third

b) 1 quarter

c) 1 fifth

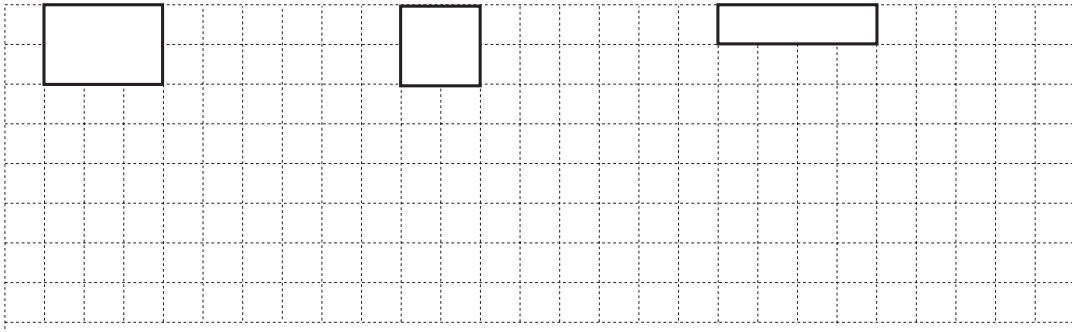

2 How much of their money did they each spend?

a) Irene had $\textcircled{100}$ $\textcircled{50}$ $\textcircled{20}$ $\textcircled{20}$ $\textcircled{10}$ and spent 1 fifth of half of her money.

.....

b) George had $\textcircled{50}$ $\textcircled{50}$ $\textcircled{50}$ $\textcircled{20}$ $\textcircled{10}$ and spent half of 1 third of his money.

.....

c) Nick had $\textcircled{100}$ $\textcircled{100}$ $\textcircled{50}$ $\textcircled{50}$ $\textcircled{20}$ $\textcircled{20}$ $\textcircled{20}$ and spent 1 third of a half.

.....

d) Jane had $\textcircled{50}$ $\textcircled{20}$ $\textcircled{20}$ $\textcircled{20}$ $\textcircled{20}$ $\textcircled{10}$ $\textcircled{10}$ $\textcircled{10}$ and spent 1 eighth of a quarter.

.....

3 Colour the parts stated. Compare the two rectangles. Fill in the missing sign.

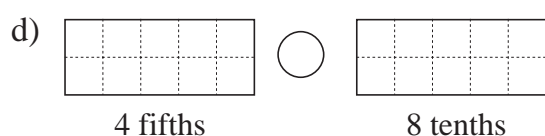
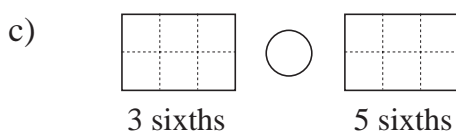
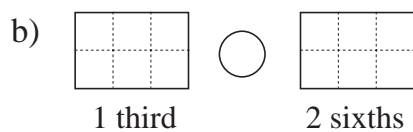
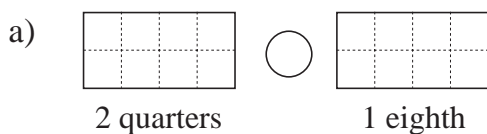

4 The middle number is the **product** of the 4 numbers around it.

Fill in the missing numbers.

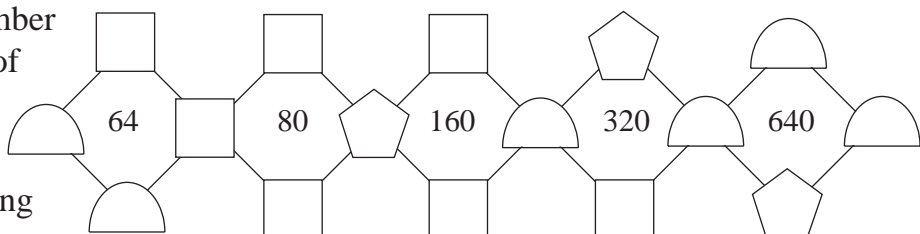











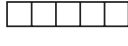

1

I planted roses in 80 square metres of my garden.  This area is 1 fifth of my whole garden. How big is my garden?

Answer:

2

Complete the table.

Unit						
Shape						
Value of shape	3					

3

Colour these shapes in the grid so that the **sum** of each shape is 500.

100	100	200	100	400	200	200	450
100	150	150	200	50	50	150	200
100	50	100	350	350	300	200	100
100	400	250	250	400	50	150	250

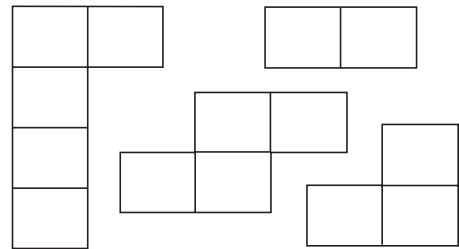

4

What is:

- a) 49 less than 123
- b) 250 more than 125
- c) 3 times more than 33
- d) 1 fifth of 110
- e) the difference between 97 and 48
- f) 1 ninth of 81
- g) the product of 18 and 4
- h) the sum of 176 and 54?

5

Join up the equal amounts.

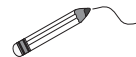

$900 - 179$

$267 + 233$

$678 - 253$

$77 + 48 + 81$

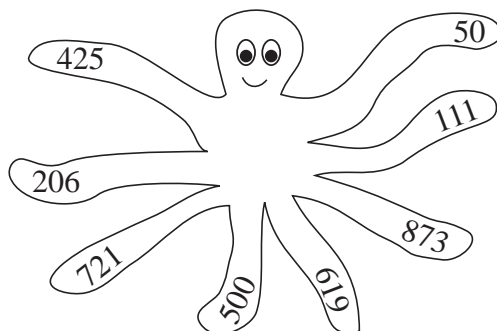

$1000 - 127$

$999 \div 9$

$700 - 9 \times 9$

1 quarter of 200

1

How many small squares are in the drawings? Write the numbers in the table.

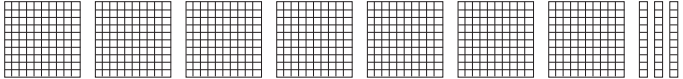
a) 

	Th	H	T	U
a)				
b)				
c)				
Total				

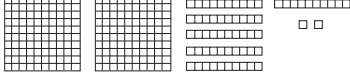
b) 

	Th	H	T	U
a)				
b)				
c)				
Total				

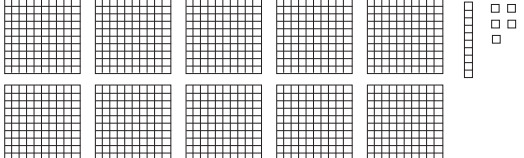
c) 

	Th	H	T	U
a)				
b)				
c)				
Total				

2

How many dots are in the drawings? Write the numbers in the table.

a) 

	Th	H	T	U
a)				
b)				
Total				

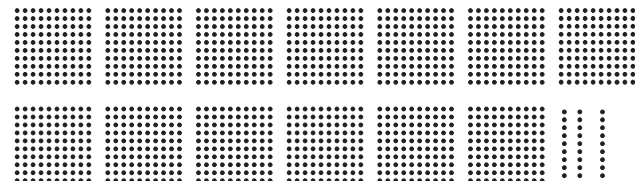
b) 

	Th	H	T	U
a)				
b)				
Total				

3

Write these numbers as digits. List them in increasing order.

six hundred and five, nine hundred and twenty, two hundred and fifty three,

nine hundred and ninety nine, six hundred and fifty one, five hundred and sixty two

..... < < < < <

4

Write these numbers in words.

- a) 304
- b) 430
- c) 403
- d) 910
- e) 109
- f) 901

1

Barry Bear tried to write the same number in different ways but he made some mistakes.



Cross out the mistakes and correct them.

9 hundreds, 4 tens and 5 units 945 $9 \times 100 + 4 \times 10 + 5 \times 1$

$900 + 50 + 4$ $90 + 45$ $800 + 100 + 45$

2

Create as many different 3-digit numbers as you can from the digits 1, 2, 3 and 4. Do not use a digit more than once in any number.

3

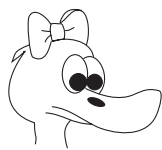

Which numbers was *Daffy Duck* thinking about?

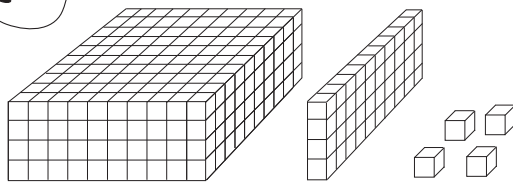
a)  =

b) If $\square = 100$, $| = 10$, and $\bullet = 1$ 

i) $\square \square | \dots$ =

ii) $\square \square \square ||| \dots$ =

iii) $\square \square \square \square$
 $\square ||| \dots$ =

iv) $\square \square \square \square$
 \dots =

v) $\square \square \square ||| \dots$ =

1

What is the rule? Continue the sequence for another 10 terms.

700, 694, 688, , , , , , , , , , ,

2

Colour with the same colour or join up the equal numbers.

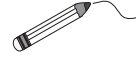

3 hundreds + 8 units	94	480	2 hundreds + 108 units
5 hundreds + 2 tens + 10 units	531	50 + 10 + 34	
2 hundreds + 200 units + 8 tens	900 - 1	500 + 20 + 10	
8 hundreds + 8 tens + 19 units	5 hundreds + 3 tens + 1 unit		

3

Write the odd numbers smaller than 600 in set **A**.
Write the even numbers greater than 800 in set **B**.

Choose from the numbers in set **U**.

$$U = \{ 488, 852, 597, 921, 940, 179, 600, 978, 341, 89, 1000 \}$$

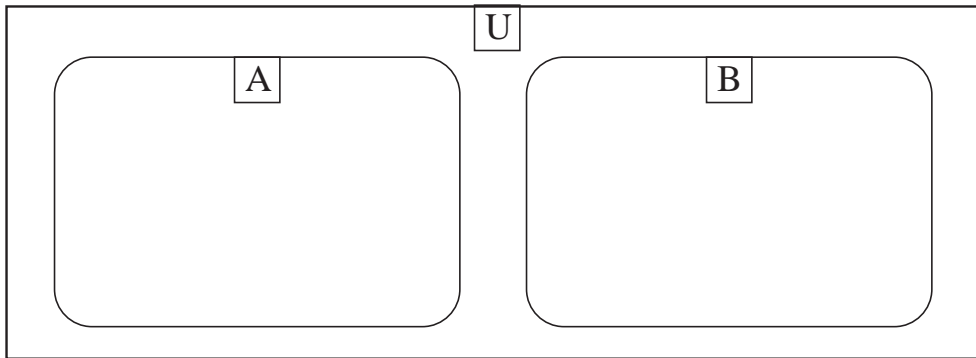

4

Complete the table.

		Th	H	T	U
568	$5 \times 100 + 6 \times 10 + 8 \times 1$				
173					
902					
430					
1245					
1050					

1

Write the numbers from set **A** in the correct boxes.

$$A = \{ 100, 305, 74, 0, 981, 1026, 1439, 1975, 2000, 1000 \}$$

a)

Even numbers	Odd numbers

b)

3-digit numbers	4-digit numbers

c)

More than 1000	Less than 1000

2

a) Add 12 to each number in **A** and write the result in **B**.

b) Decide whether the statements are true or false. Write ✓ or ✗ in the box.

A		B
111	$\xrightarrow{+12}$	
112	$\xrightarrow{+12}$	
113	$\xrightarrow{+12}$	
122	$\xrightarrow{+12}$	
123	$\xrightarrow{+12}$	
133	$\xrightarrow{+12}$	
222	$\xrightarrow{+12}$	
223	$\xrightarrow{+12}$	
233	$\xrightarrow{+12}$	
333	$\xrightarrow{+12}$	

i) **A** contains all 3-digit numbers with digits 1, 2 and 3.

ii) **B** contains all 3-digit numbers with different digits from the set $\{ 1, 2, 3, 4, 5 \}$ and the digits are increasing.

iii) None of the numbers in **A** have digits which are decreasing.

1

Write the numbers as digits.

a) Th H T U b) Th H T U c) Th H T U d) Th H T U

2

Write these numbers as digits. Which is more? Write in the correct sign. (<, =, >)

- a) 6 hundred and 5 = ○ = 6 hundred and 50
- b) 9 hundreds + 2 tens = ○ = 9 hundreds + 1 ten + 9 units
- c) 2 hundreds + 1 ten + 7 = ○ = 2 hundreds + 0 tens + 9 units
- d) 7 hundred and 13 = ○ = 7 hundreds + 2 tens

Colour *yellow* the boxes which contain even numbers.

3

a) Complete the table.

			Th	H	T	U
i)	320	$3 \times 100 + 2 \times 10 + 0 \times 1$				
ii)	951					
iii)	888					
iv)	603					
v)	1071					
vi)	3540					

b) Write the numbers in the table in words.

- i)
- ii)
- iii)
- iv)
- v)
- vi)

1

Calculate:

$26 + 13 =$	$260 + 130 =$	$58 - 32 =$	$580 - 320 =$
$18 + 42 =$	$180 + 420 =$	$70 - 21 =$	$700 - 210 =$
$56 + 44 =$	$560 + 440 =$	$100 - 59 =$	$1000 - 590 =$
$135 + 48 =$	$1350 + 480 =$	$146 - 18 =$	$1460 - 180 =$
$164 + 36 =$	$1640 + 360 =$	$200 - 35 =$	$2000 - 350 =$

2

Calculate:

a) $7 \times 1 =$	$11 \times 1 =$	b) $19 \times 10 =$	$119 \times 10 =$
$7 \times 10 =$	$11 \times 10 =$	$7 \times 100 =$	$10 \times 70 =$
$7 \times 100 =$	$11 \times 100 =$	$19 \times 100 =$	$10 \times 190 =$
c) $900 \div 1 =$	$1000 \div 1 =$	d) $600 \div 100 =$	$600 \div 10 =$
$900 \div 10 =$	$1000 \div 10 =$	$800 \div 100 =$	$800 \div 10 =$
$900 \div 100 =$	$1000 \div 100 =$	$1200 \div 100 =$	$1200 \div 10 =$

3

Write numbers in the circles so that the sum of the 3 numbers along each line is 1000. Choose from: 260, 280, 300, 320, 340, 360, 380, 400.

a)

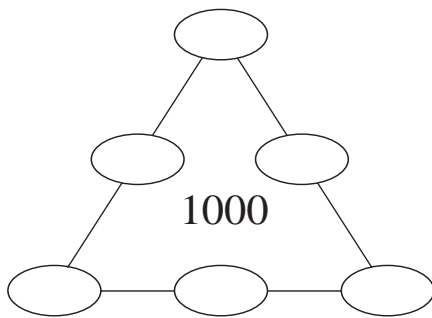

b)

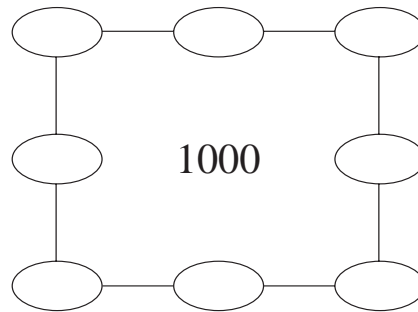
**4**

Write the numbers as Roman numerals.

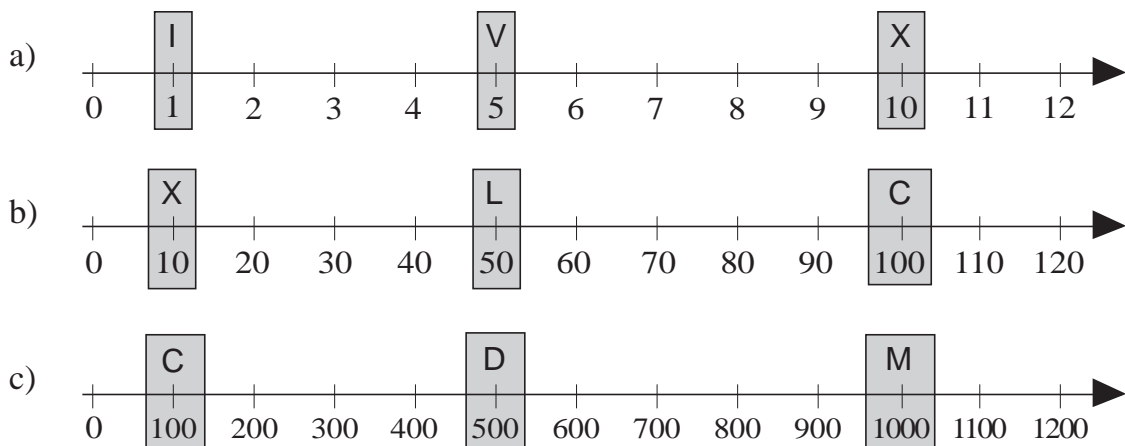

1

Write these numbers as Roman numerals.





- a) $100 + (50 + 10) + (1 + 1)$ b) $(500 + 100) + (50 - 10) + (1 + 1)$

 c) $1000 + (500 + 100) + 1$ d) $(1000 - 100) + (50 + 10) + 5$

 e) $1000 + (100 + 100) + (5 + 1)$ f) $(500 + 100 + 100) + (10 + 10 + 10)$

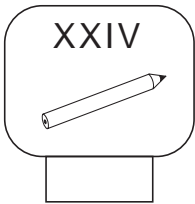
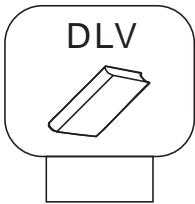
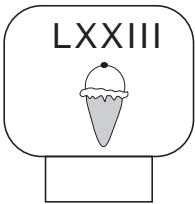
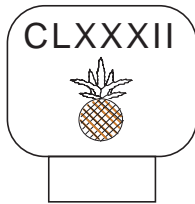
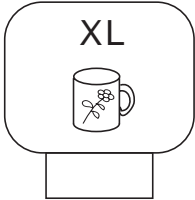
2

How many pence do these items cost? Write the amounts as Arabic numbers.

- a)  b)  c)  d) 
 e)  f)  g)  h) 

3

Write these numbers as Roman numerals. For example:

$628 = (500 + 100) + (10 + 10) + (5 + 1 + 1 + 1) = DCXXVIII$			
DC	XX	VIII	

- a) $756 = (500 + 100 + 100) + 50 + (5 + 1) =$
 b) $435 = (500 - 100) + (10 + 10 + 10) + 5 =$
 c) $263 = ($
 d) $974 = ($ $) +$

4

Which is more?
How many more?

- a) CLIV CLVI b) DXXIX DXXXII
 c) M DCCCX d) CCCL CCCXX

1

Which numbers do the letters stand for? Write the numbers in the boxes.

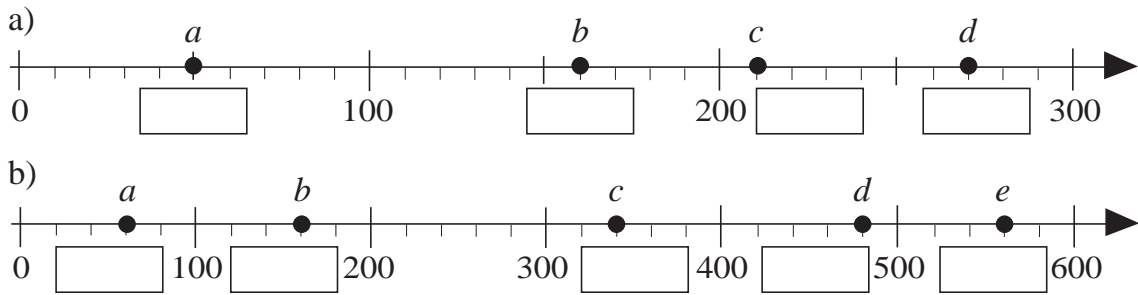

2

Join up the letters to the matching numbers.

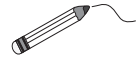

460, 510, 600, 605, 798, 850, 972, 975, 1420, 1600, 1703

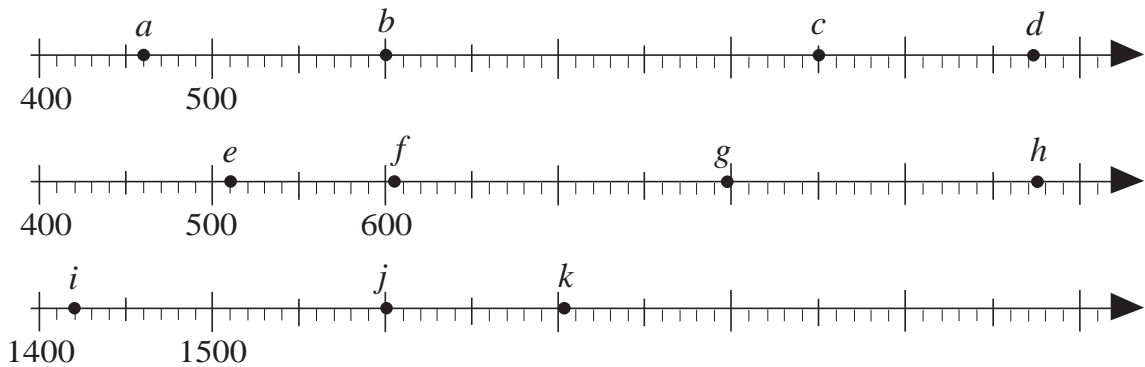

3

Which whole numbers make each statement true? Mark them on the number line. Write down the highest and lowest possible numbers.

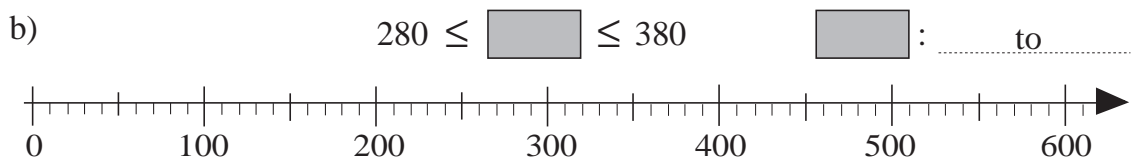
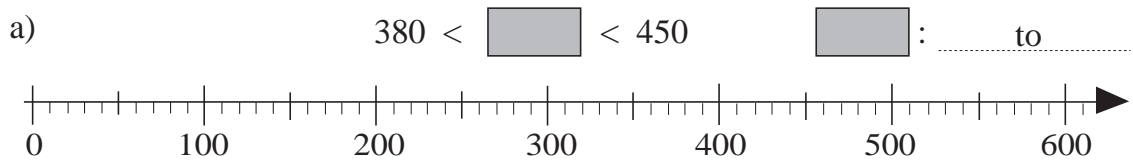

4

Continue the sequences.

- a) 1, 2, 4, 8, 16,
- b) 1, 4, 9, 16, 25,
- c) 0, 1, 1, 2, 3, 5, 8,
- d) 1, 3, 6, 10, 15,

1

Study the numbers in set **B**. Complete the sentences so that they are correct.

$$B = \{ 144, 273, 50, 18, 705, 1001, 850 \}$$

- a) All these numbers
- b) Not all these numbers
- c) None of these numbers
- d) There is at least one number which
- e) There are no numbers which
- f) There is at least one number which is not

2

Fill in the missing numbers.

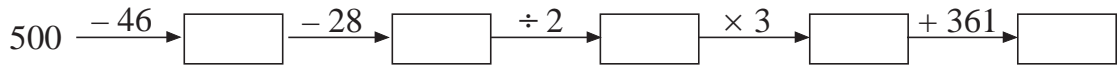



Write the operations in reverse order.



3

Complete the table. Write the rule in different ways.

	475	625		217	37	475		111	456
	360		1002	555	926		382	765	
	835	960	1012			1000	500		850

$$\text{moon} =$$

$$\text{star} =$$

$$\text{sun} =$$

4

Write these numbers as Roman numerals.

- a) 653 b) 402 c) 317 d) 528 e) 1010
-

5

A glass full of milk weighs 370 g. When the glass is half full of milk it weighs 290 g. What does the empty glass weigh?

Answer:

1

List the whole numbers which have these numbers as their nearest whole ten.

- a) 60:
- b) 100:
- c) 580:
- d) 1500:
- e) 0:

2

Mark on the number line the numbers which have these numbers as the nearest whole hundred:

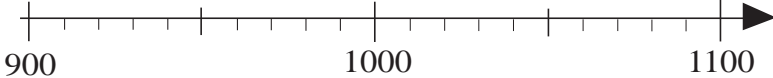
- a) 500: 
- b) 1000: 

3

Decide whether the quantities in the answers are **exact** or **approximate**.

Write = or \approx in the boxes.

- a) Ann asked the shop assistant about the price of a computer.
The shop assistant said, "It is £400."
- b) Brian asked a policeman how far it was to the Library.
The policeman said, "It is 400 metres further on."
- c) Cindy asked her mother how many buttons were in her button box.
Her mother said, "There must be 100 buttons in the box."
- d) Dennis asked the storeman how many screws were in a packet.
The storeman said, "There are 150 screws in a packet."

4

Round these numbers to the nearest

- a) ten: 138 \approx 134 \approx 135 \approx 574 \approx
 577 \approx 575 \approx 1405 \approx 1404 \approx
 1408 \approx 992 \approx 999 \approx 995 \approx
- b) hundred: 992 \approx 999 \approx 995 \approx 138 \approx
 134 \approx 135 \approx 574 \approx 577 \approx
 575 \approx 1405 \approx 1404 \approx 1408 \approx

1

List the whole numbers which :

- a) round to 500 as the nearest hundred and have 5 as the tens digit.
.....
- b) round to 500 as the nearest hundred and have 4 as the tens digit.
.....
- c) round to 500 as the nearest hundred and also as the nearest ten.
.....

2

Which digits can the letters represent so that if the numbers are rounded to:

- a) the nearest ten, the value is 360
 $\boxed{a}56$ $\boxed{b}64$ $3\boxed{c}5$ $3\boxed{d}3$ $35\boxed{e}$ $36\boxed{f}$

- b) the nearest hundred, the value is 400?
 $\boxed{g}50$ $\boxed{h}49$ $3\boxed{i}1$ $4\boxed{j}9$ $35\boxed{k}$ $44\boxed{l}$

3

Round these numbers to:

- | | |
|--|---|
| <ul style="list-style-type: none"> a) the nearest ten 1006 \approx 1005 \approx 1001 \approx 1753 \approx 1759 \approx 1750 \approx | <ul style="list-style-type: none"> b) the nearest hundred. 1006 \approx 1005 \approx 1001 \approx 1753 \approx 1759 \approx 1750 \approx |
|--|---|

4

Two different numbers round to 300 as the nearest hundred. Is it possible that:

- a) both numbers are less than 300
- b) the smaller number is 100 less than the other number
- c) one number has 5 and the other has 0 as the tens digits
- d) both numbers are whole hundreds?

1

Estimate the length of the routes in the drawings first, then measure them.

How long are the routes really if 1 cm in the drawing means 10 m in real life?

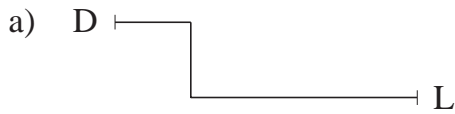

Estimate: cm
 Length: mm = cm
 Length in real life: m

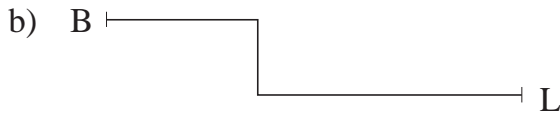

Estimate: cm
 Length: mm = cm
 Length in real life: m



Estimate: cm
 Length: mm = cm
 Length in real life: m

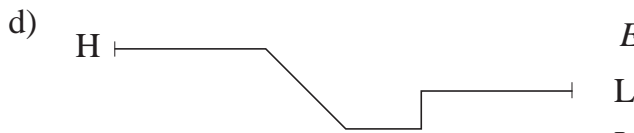

Estimate: cm
 Length: mm = cm
 Length in real life: m

2

Write these lengths in millimetres.

a) 2 cm = mm, 11 cm = mm, 105 cm = mm

b) 5 cm = mm, 20 cm = mm, 132 cm = mm

c) 9 and a half cm = mm, 57 and a half cm = mm,
 half a cm = mm, 123 and a half cm = mm

3

Change the units of length.

a) 25 mm = cm mm b) 2 m = cm mm

125 mm = cm mm 2 and a half m = cm

82 mm = cm mm 12 m = cm

382 mm = cm mm 642 cm = m cm

1

Round these lengths to:

a) the nearest 10 mm

b) the nearest 100 mm

184 mm \approx

184 mm \approx

687 mm \approx

687 mm \approx

185 mm \approx

185 mm \approx

205 mm \approx

205 mm \approx

100 mm \approx

100 mm \approx

372 mm \approx

372 mm \approx

2

The length of a line is about 12 cm, rounded to the nearest cm.
How long could the actual length of the line be?

Draw 4 possible lines accurately. Write the actual length below each line.

3

a) Write these lengths in millimetres.

i) 12 cm = mm

ii) 3 cm 3 mm = mm

1 cm 2 mm = mm

30 cm 3 mm = mm

10 cm 2 mm = mm

3 m 30 cm = mm

102 cm = mm

3 m 3 cm = mm

120 cm = mm

3 m 3 mm = mm

1 m 2 cm = mm

33 cm 3 mm = mm

1 m 2 mm = mm

30 cm 30 mm = mm

b) List them in increasing order.

i)

.....

ii)

.....

1

Round the lengths given in millimetres to the nearest centimetre. Follow this pattern:

$$658 \text{ mm} \approx 660 \text{ mm}, \quad 660 \text{ mm} = 66 \text{ cm}$$

$$658 \text{ mm} \approx 66 \text{ cm}$$

- a) $324 \text{ mm} \approx \square \text{ cm}$
- b) $530 \text{ mm} \approx \square \text{ cm}$
- c) $799 \text{ mm} \approx \square \text{ cm}$
- d) $2002 \text{ mm} \approx \square \text{ cm}$

2

Join up these numbers to the **approximate** place on the number line. 

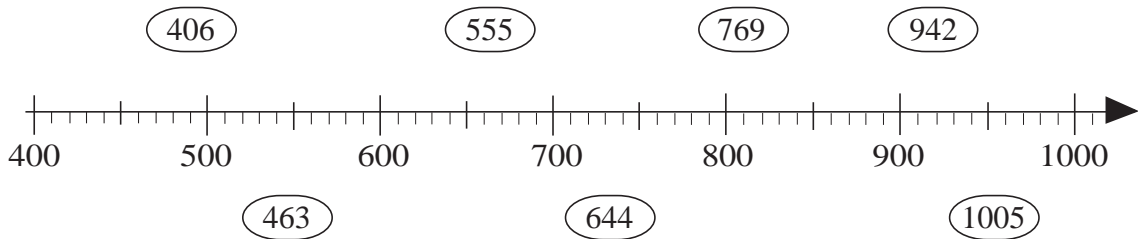

3

a) Complete the table.

Number	Rounded to nearest 10	Rounded to nearest 100
943		
304		
184		
765		
125		
550		
247		
805		

b) List all possible whole numbers which have:

- 5 as the tens digit when rounded to the nearest ten,
- and also
- 5 as the hundreds digit when rounded to the nearest hundred.