

UNITS 7 – 9

Miscellaneous Exercises



Note

Starred* questions are for *Academic Route* only.

1.

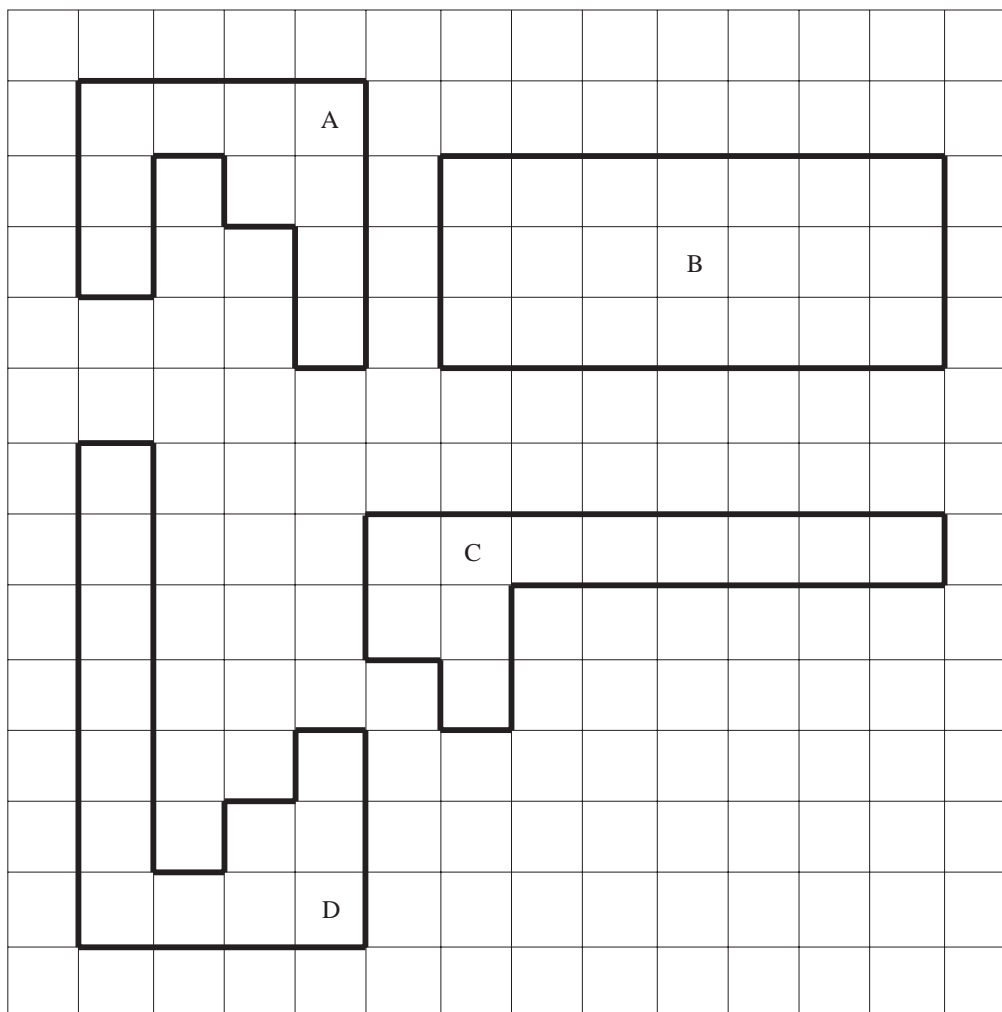

- (a) Write down the perimeter of shape D.
- (b) What is the area of shape B?
- (c)
 - (i) Which shape has the smallest area?
 - (ii) What is the area of this shape?

(NEAB)

2. At Booth Outdoor Centre the water storage tank is a cuboid of dimensions 2 m by 1 m by 1.5 m.

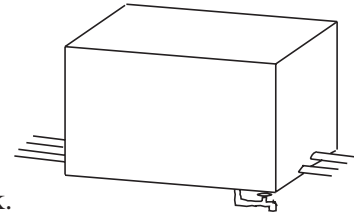

- (a) Calculate the volume of the water storage tank.
- (b) The mugs used at the centre are all cylindrical with a radius of 4 cm and a height of 9 cm.
How much water does a full mug hold?

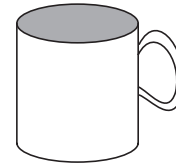

- (c) The warden at the Centre claimed that from one full tank, you get over 6000 full mugs of water.
Is the warden correct? Show all your working.

(NEAB)

3. (a) Calculate the area of a circle with radius 1.2 cm.
(b) What is the radius of a circle with an area of 66 cm^2 ?

(NEAB)

4. The three-dimensional shape has lengths $AB = 3 \text{ cm}$, $BC = 4 \text{ cm}$ and $BE = 6 \text{ cm}$.
(a) An isometric view of the shape has been started on the isometric paper.
Copy and complete the drawing.

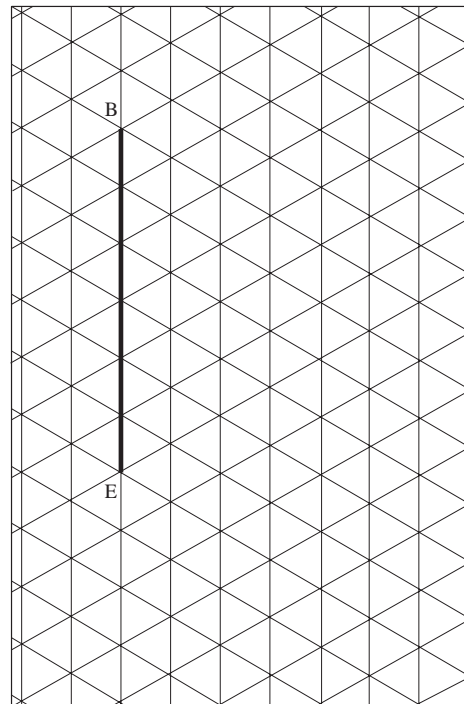
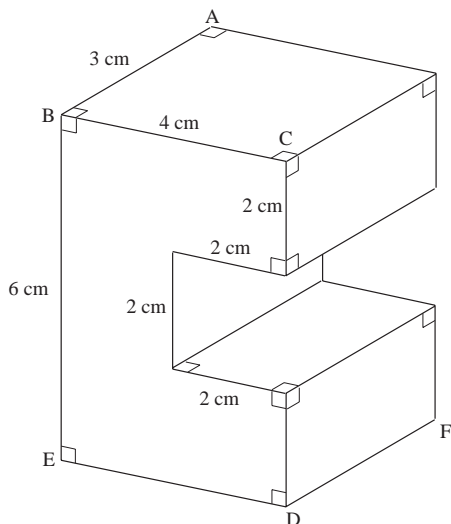

- (b) Calculate the volume of the shape.

(SEG)

5. The train on a children's roundabout goes round in a circle of diameter 6 m.

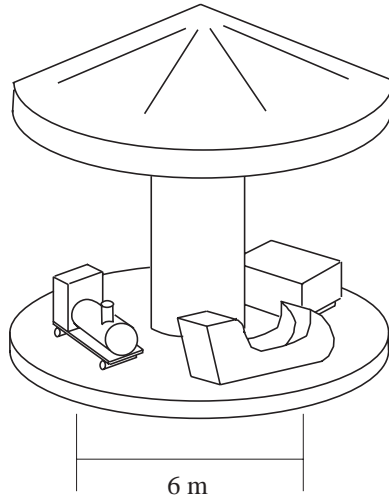

- (a) (i) Calculate the circumference of the circle.
 (ii) James rides on the train and travels 165 m.
 How many complete turns does he go round?

The floor of the roundabout has a radius 3.5 m.

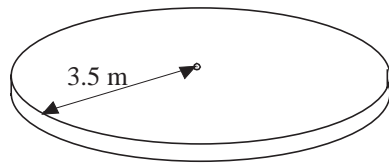

- (b) Calculate the area of the floor.

(SEG)

6. The diagram shows a shape.

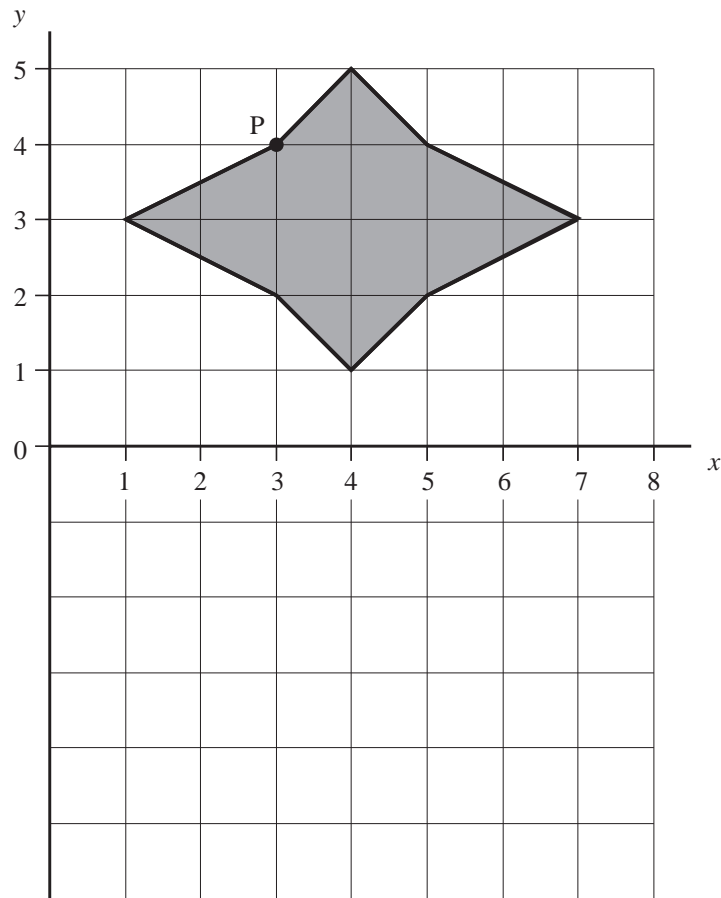

- What are the coordinates of P?
- Each square on the diagram has an area of 1 cm^2 .
What is the area of the shape?
- The shape has rotational symmetry.
Copy the diagram and mark with a cross the centre of rotation.
- The shape is reflected in the mirror line Ox .
Draw the reflected shape on your diagram.

(SEG)

7. A salt container is in the shape of a cylinder.

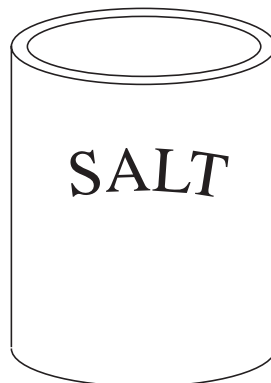

Not to scale

- (a) The base of the cylinder has a radius of 3 cm.
Calculate the area of the base.
- (b) The volume of the cylinder 565 cm^3 .
Calculate the height of the cylinder.

(SEG)

8. The diagram is a drawing of a triangular prism.

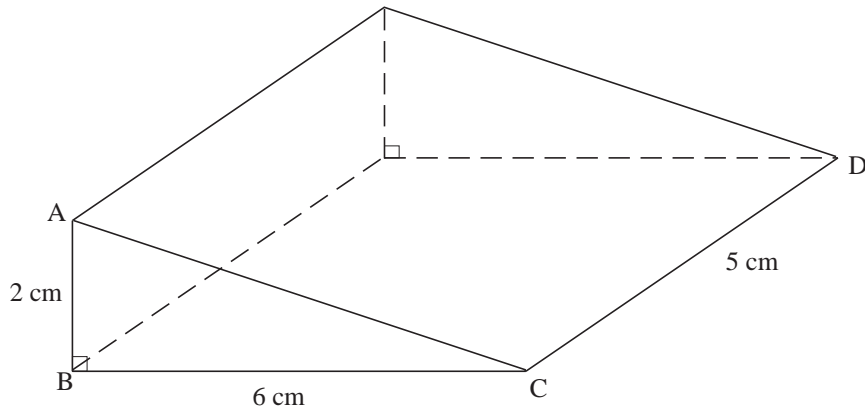

- (a) Calculate the area of the triangle ABC.
- (b) Calculate the volume of the prism.

(NEAB)

9. (a) A circle has a radius of 28 cm.
Calculate its circumference.

- (b)

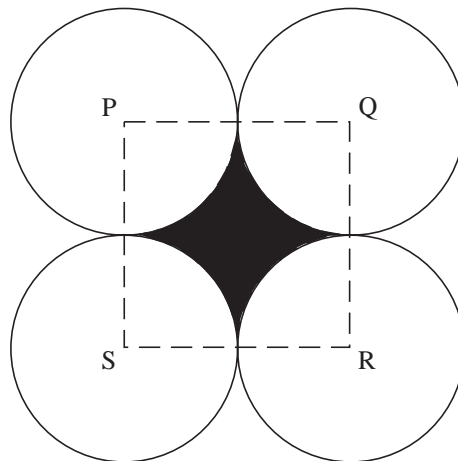

Not to scale

The diagram shows four touching circles.

Each circle has a radius of 28 cm.

P, Q, R and S are the centres of the circles.

PQRS is a square.

- (i) What is the perimeter of the shade region?
- (ii) Calculate the area of the shaded region.

(NEAB)

- * 10. A farmer's storage container is in the shape of a cylinder with a hemisphere on top. The height of the cylinder is 9.5 m. The radius of both the cylinder and the hemisphere is 2.4 m.

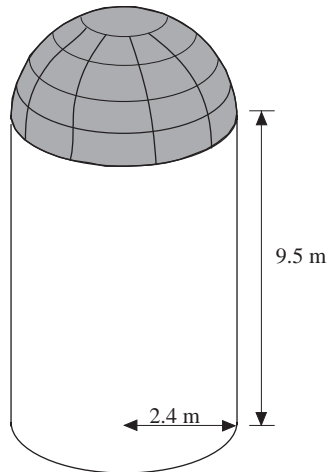

- (a) Calculate the volume of the farmer's storage container.
- (b) The volume of a similar storage container is half the volume of the farmer's container. Calculate the radius of this new container.

(SEG)

- * 11. The diagram shows a window. The arc AB is a semicircle. $BC = AD = 75$ cm, $DC = 80$ cm.

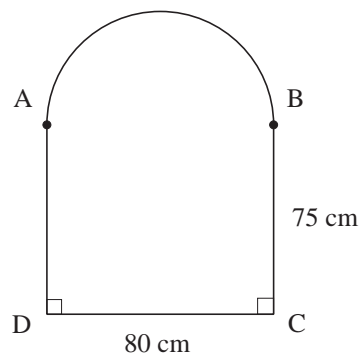

Not to scale

Calculate the area of the window.

(SEG)

*

12. The sloping sides of a flower bowl are part of a cone as shown.

The radius of the top of the bowl is 10 cm and the radius of the bottom of the bowl is 5 cm. The height of the full cone is 24 cm.

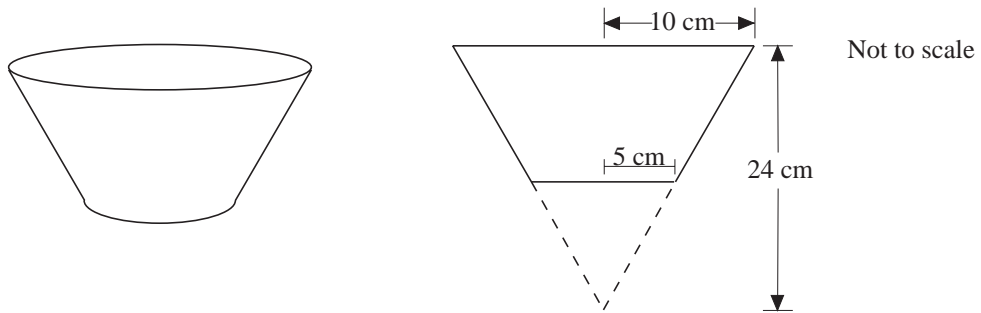

- (a) Calculate the volume of the full cone.
 (b) **By using similar figures**, calculate the volume of the flower bowl.

(NEAB)

13. Shara collected data on the colour of different vehicles passing her home.

The table shows the results of her survey.

		Type of Vehicle				Total
		Car	Van	Lorry	Bus	
Colour of Vehicle	Red	15	2	3	5	25
	Blue	9	3	2	0	14
	White	9	4	1	0	14
	Green	2	2	2	1	7
	Total	35	11	8	6	60

- (a) Which colour of vehicle is the mode?
 (b) Draw a pie chart to show the proportion of each type of vehicle.
 Label your pie chart clearly.

(SEG)

14. A daily newspaper has 32 pages.

The pie chart shows the proportion of each section of the newspaper.

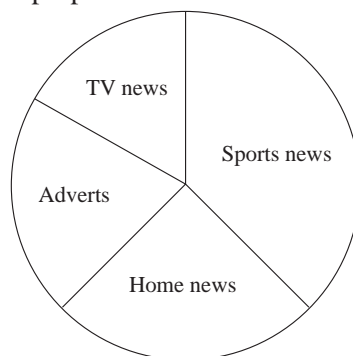

Calculate how many pages of Sports news the paper contains.

(SEG)

15. Jane tries to find out which letters of the English alphabet are used most often. She carries out a survey. Her results are shown below.

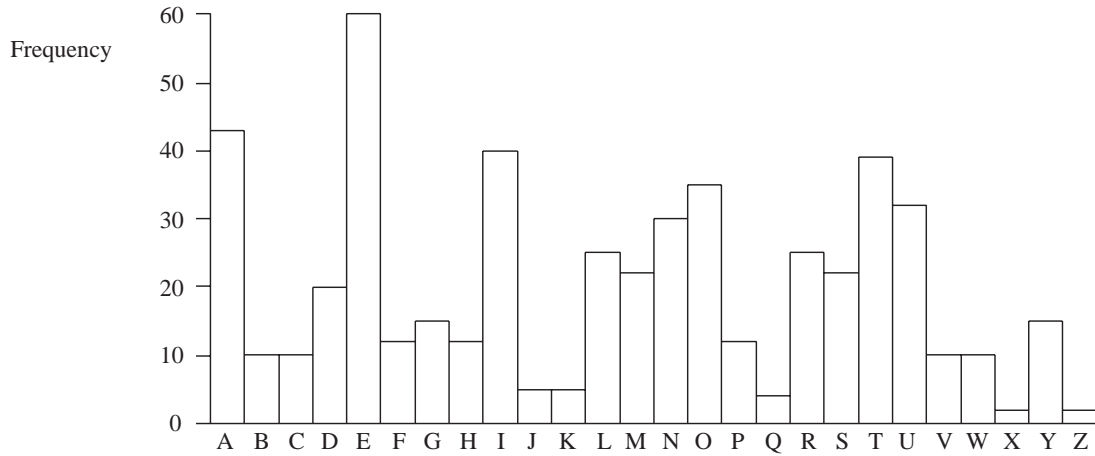

- (a) (i) Which four letters are used most often?
 (ii) Explain why a pie chart is **not** a suitable way to display these results.
- (b) Peter does a similar survey. He finds that a different set of four letters are used most often. Why do you think that Peter's four letters are different from Jane's?

(NEAB)

16. The graph shows the results of a survey of the lengths of leaves.

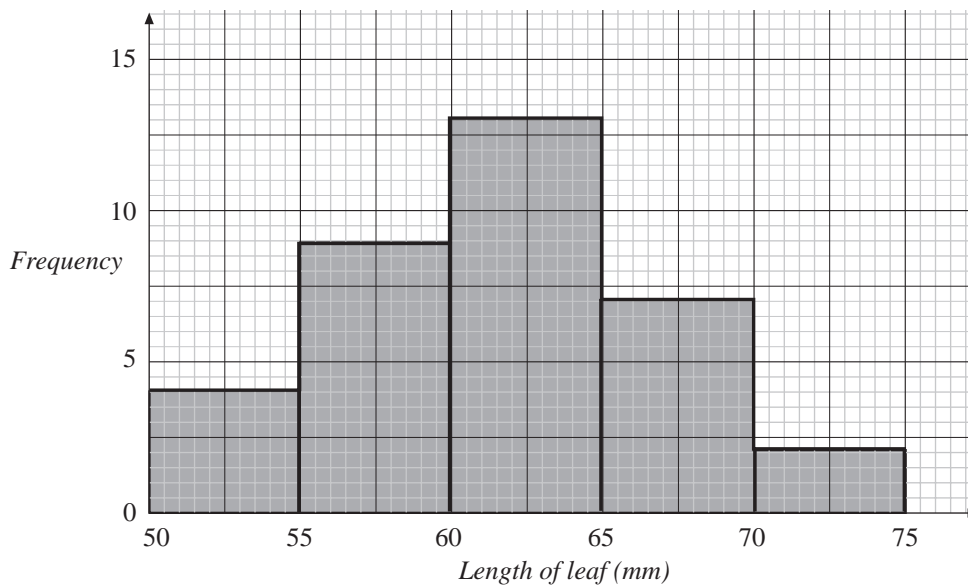

- (a) Complete a frequency table for these results.
- (b) A new leaf is picked. Use the above information to estimate the probability that the leaf has a length between 60 and 65 mm.

(SEG)

17. A gardener tests a fertiliser.
He grows some tomatoes with the fertiliser and some without.
He records the weights of all the tomatoes grown.

weight (grams)	frequency	
	with fertiliser	without fertiliser
$50 < W \leq 100$	10	2
$100 < W \leq 150$	15	42
$150 < W \leq 200$	55	46
$200 < W \leq 250$	53	41
$250 < W \leq 300$	17	34
$300 < W \leq 350$	8	1

- (a) Draw a frequency polygon for each distribution on a grid like the one below, clearly indicating which is **with fertiliser**, and which is **without fertiliser**.

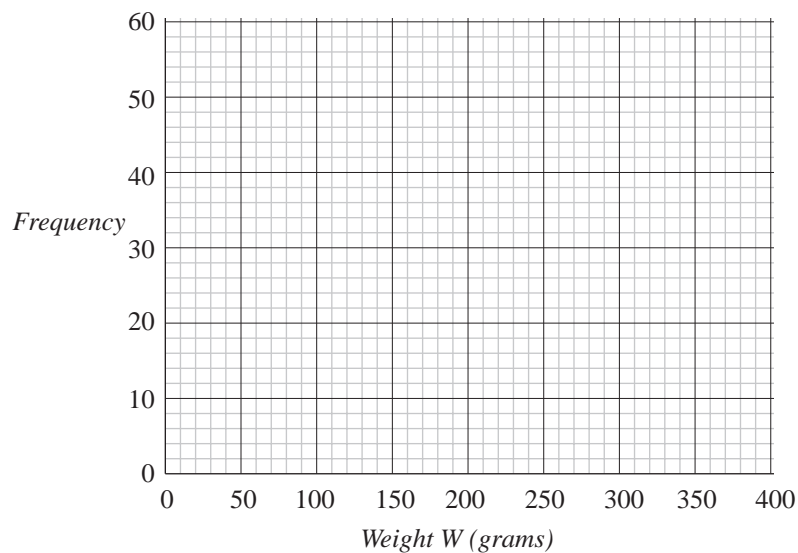

- (b) Use the frequency polygons to compare the effects of the fertiliser.

(NEAB)

18. There is to be a survey about the need for a new leisure centre in a town.

- (a) State why the following question is **not** suitable for use in a questionnaire.

"Do you agree that tennis courts are more important than squash courts?"

- (b) Rewrite the question in a suitable form.

(SEG)

19. Two groups take the same Maths test.

The test is marked out of 50.

Graham writes down the marks for his group.

25, 47, 49, 31, 38, 24, 19, 22, 38, 25.

- (a) Calculate the mean mark for this group.
 (b) What is the range of marks for this group?

Arpita writes down the marks for her group.

The lowest mark is 12.

The range is 30.

- (c) What is the highest mark for her group?

The mean for her group is 25.

- (d) Compare the results of the two groups.

(NEAB)

20. There are 24 people in an old people's home.

There are 15 women.

Their ages are shown below.

98	85	87	75	71	69	76	82
93	94	78	77	91	90	79	

- (a) (i) What is the range of the ages of the women?
 (ii) Calculate the mean age of the women.

All the people in the home are 65 years old or more.

The men have a mean age of 71 years.

The range of the ages of the men is 34 years.

- (b) What is the sex of the oldest person in the home?

Give a reason for your answer.

(SEG)

21. A survey was carried out on the shoe sizes of 25 men.

The results of the survey were

10	6	9	8	9	8	6	7	9
9	7	7	9	10	9	8	9	8
5	8	8	9	10	8	7		

- (a) (i) What is the mode of the shoe sizes?
 (ii) What is the median of the shoe sizes?

This frequency diagram shows the results of a survey of the shoe sizes of 25 women.

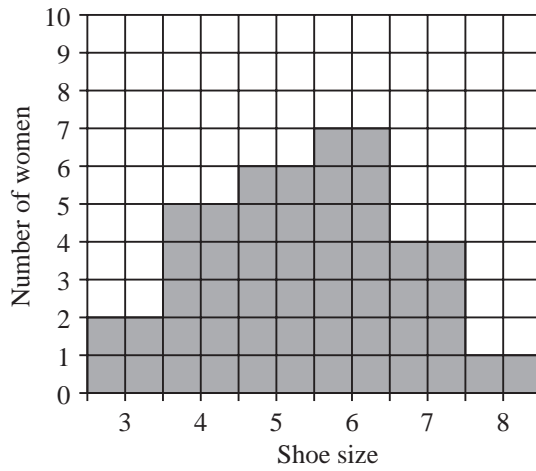

(b) Using your answers from part (a) make **two** different comparisons between the shoe sizes of men and women.

(SEG)

22. There are 14 women in a nursing home.

The graph shows the distribution of their ages.

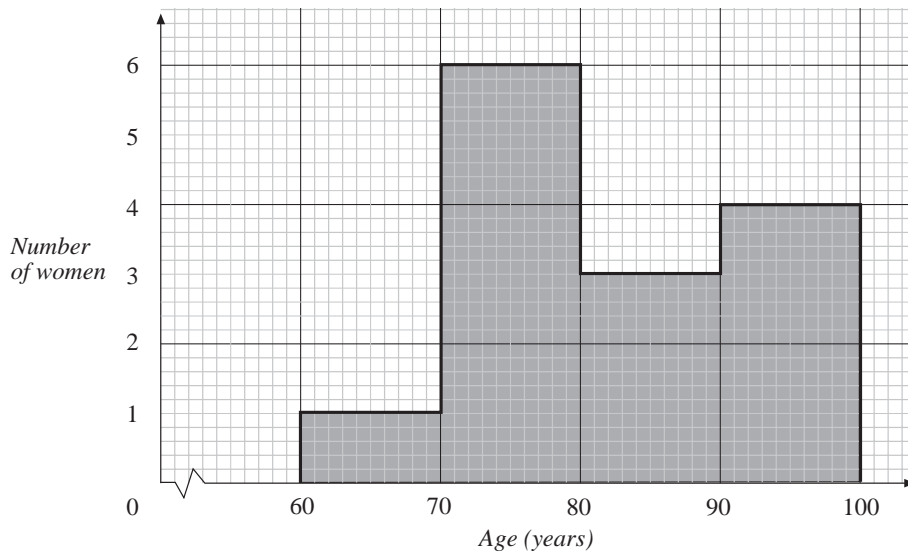

(a) Complete the table for these data.

Age y years	Number of women
$60 \leq y < 70$	
$70 \leq y < 80$	
$80 \leq y < 90$	
$90 \leq y < 100$	

(b) Calculate an estimate of the mean age of these women.

(SEG)

*

23. The following data refers to the average number of paid hours worked by 5000 men and 5000 women per week in the UK in 1990.

Women			Men		
Number of hours	percentage frequency	cumulative percentage frequency	Number of hours	percentage frequency	cumulative percentage frequency
$0 \leq x < 10$	8	8	$0 \leq x < 10$	2	2
$10 \leq x < 20$	17	25	$10 \leq x < 20$	3	5
$20 \leq x < 30$	18	43	$20 \leq x < 30$	1	
$30 \leq x < 40$	47	90	$30 \leq x < 40$	56	
$40 \leq x < 50$	9	99	$40 \leq x < 50$	35	
$50 \leq x < 60$	1	100	$50 \leq x < 60$	3	

- (a) Complete the table to show the cumulative percentage frequency of the paid hours worked by men.

The graph shows the cumulative percentage frequency of the paid hours worked by women.

- (b) Copy the grid and draw also the cumulative percentage frequency of the paid hours worked by men.
- (c) By finding the interquartile ranges of the two distributions, state whether men or women had the greater variability in the number of paid hours worked per week.

