

7 Mensuration

7.1 Using and Measuring

1. Measure each line below. Give its length to the nearest mm and nearest cm.

(a) _____

(b) _____

(c) _____

2. Which units would be most suitable for measuring.

(a) the length of a garden

(b) the length of a shoe

(c) the mass of a bag of apples

(d) the volume of a glass of milk

3. (a) How many grams are there in 8.21 kg ?

(b) How many cm are there in 4.27 m ?

(c) How many mm are there in 2.5 cm ?

(d) How many grams are there in 3.148 kg ?

4. Copy and complete the table below

m	Length in cm	mm
32		
		975
	762	
7.14		

5. Read off the value shown by the arrow on each of the following scales:

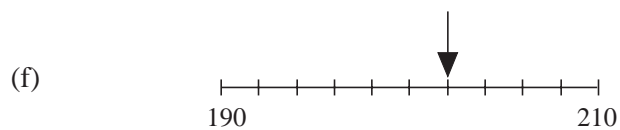
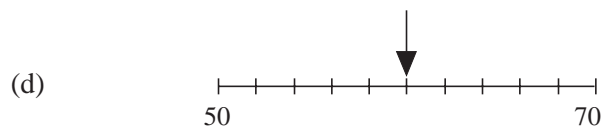
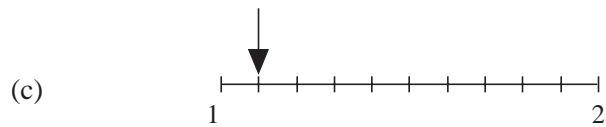
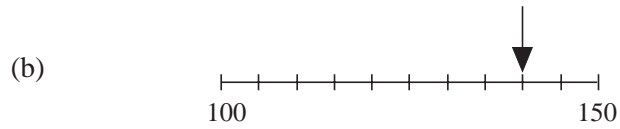
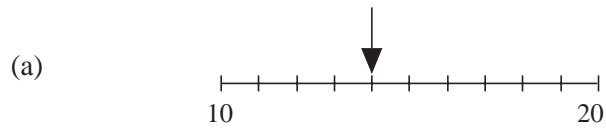

6. State whether the following lengths would be best measured to the nearest km, m, cm or mm:

- (a) the length of a car,
- (b) the height of a house,
- (c) the length of a train,
- (d) the distance between two towns,
- (e) the length of a drawing pin,
- (f) the diameter of a screw hole in a bookcase.

7. Give each of the following to the nearest (i) cm (ii) m:

- (a) 1572 mm (b) 632 mm (c) 92 mm

8. Change 3.25 m^3 to cm^3 .

(Edexcel)

9. (a) Copy and complete the table by writing a sensible metric unit on each dotted line. The first one has been done for you.

The distance from London to Manchester	222 kilometres
The volume of coffee in a mug	310
The height of a door	215
The weight of a one pound coin	12

- (b) Change 8 kilometres to metres.

(Edexcel)

10. (a) Write down the length of this stick.

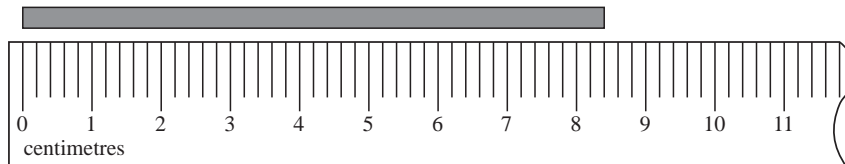

- (b) Tom has a toy car.

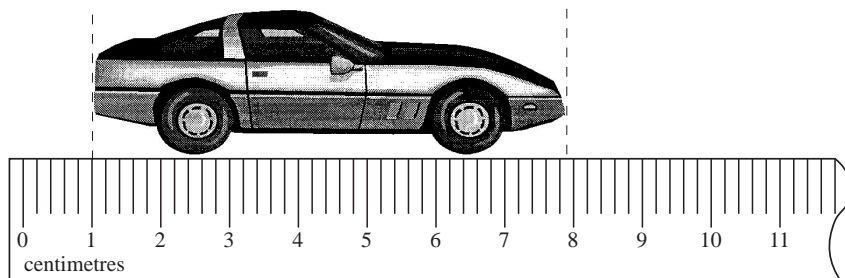

What is its length in **millimetres**?

(AQA)

11. Give the values shown by the arrows on these scales.

- (a)

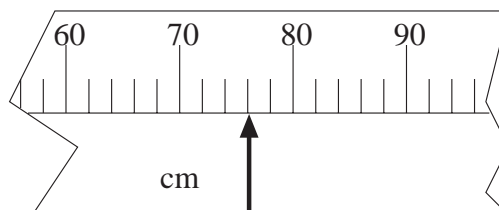

(b)

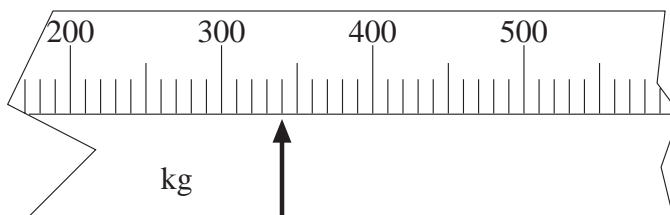

(c)

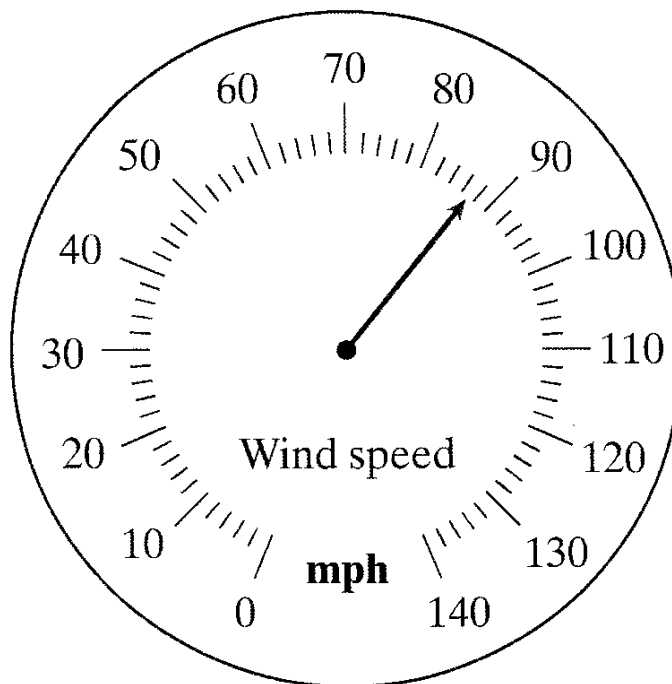

(AQA)

7.2 Estimating Areas

1. Find the area of each of the shaded shapes below

(a)

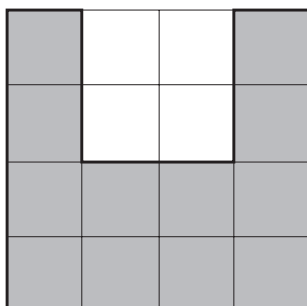

(b)

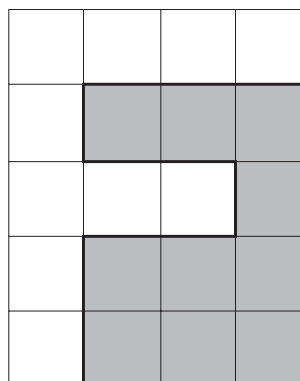

2. By counting the number of whole squares and half squares, find the area of each of the following shapes:

(a)

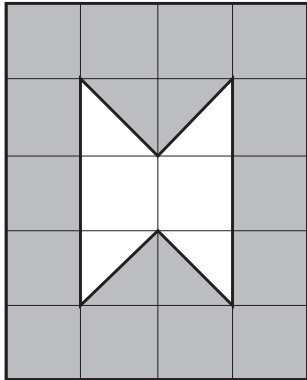

(b)

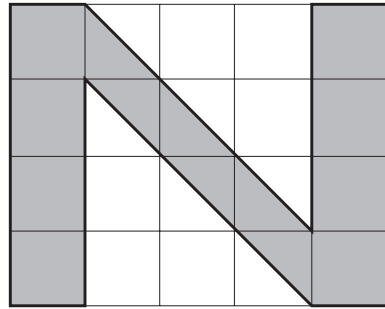

(c)

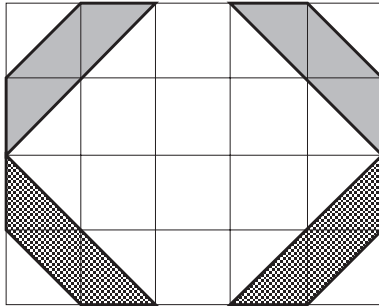

3. Estimate the area of each of the following:

(a)

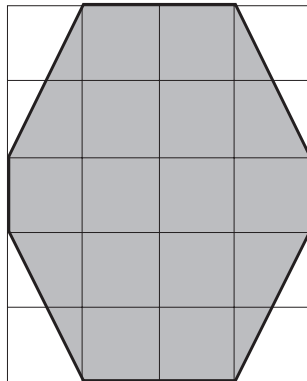

(b)

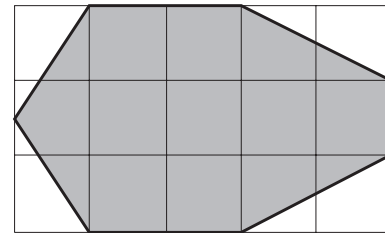

(c)

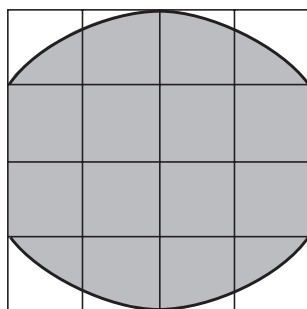

(d)

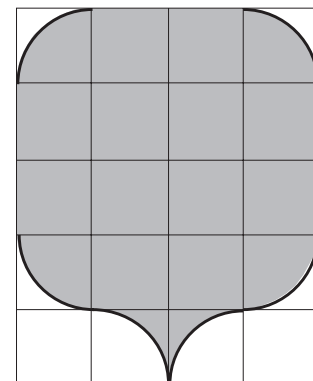

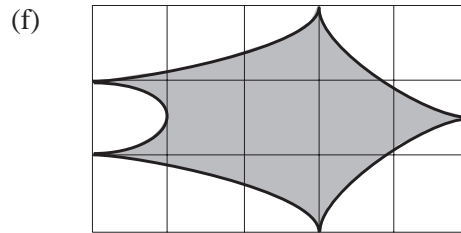
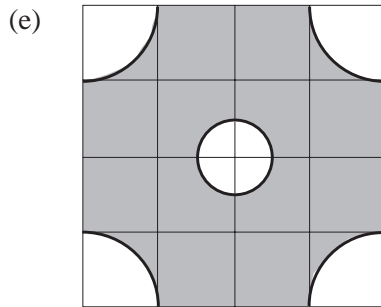

4. The diagram below shows the outline of an island. The grid squares each represent a length of 1 km. Estimate the area of the island.

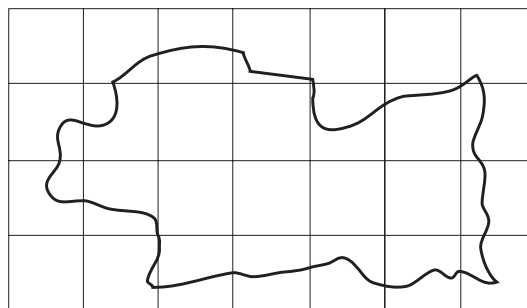

7.3 Making Solids Using Nets

1. Copy each net shown, add flaps, and make it into a solid. In each case, state the name of the solid.

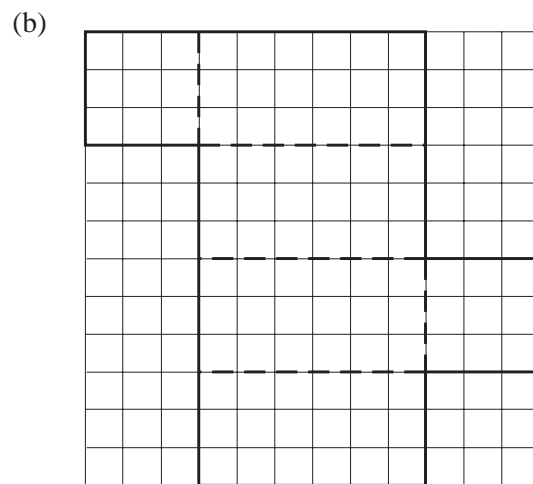
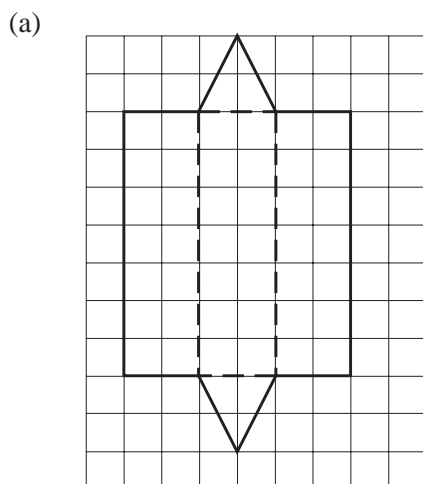

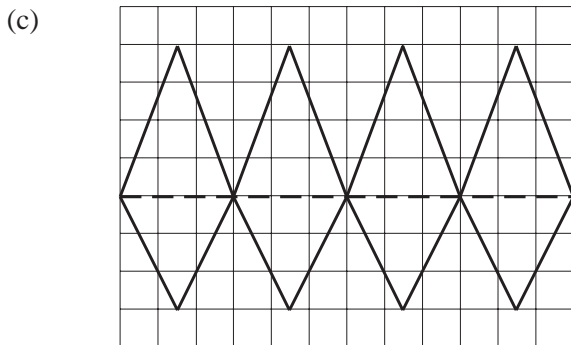

2. (a) Write down the name of each of these 3-D shapes.

(i)

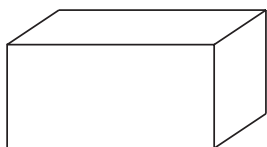

(ii)

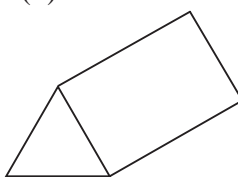

(iii)

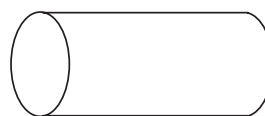

(b) Here is a net for another 3-D shape.

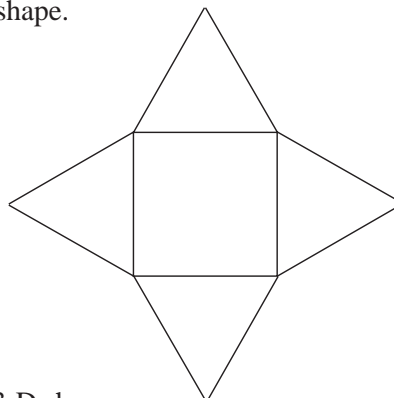

Write down the name of this 3-D shape.

(AQA)

3. Below is the net of a solid.
All the lines drawn are the same length.

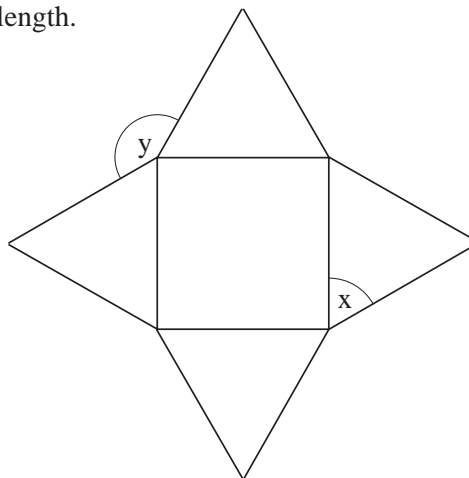

(a) Write down the full mathematical name of the solid that the net will make.

- (b) Measure and write down the length of one of the lines in the diagram.
- (c) Measure and write down the size of angle
- (i) x ,
- (ii) y .
- (d) What is the special mathematical name given to the triangles in this net?
- (e) Draw the lines of symmetry of the net on a copy of the diagram above.

(OCR)

7.4 Constructing Nets

1. Draw an accurate net for each of the following cuboids:

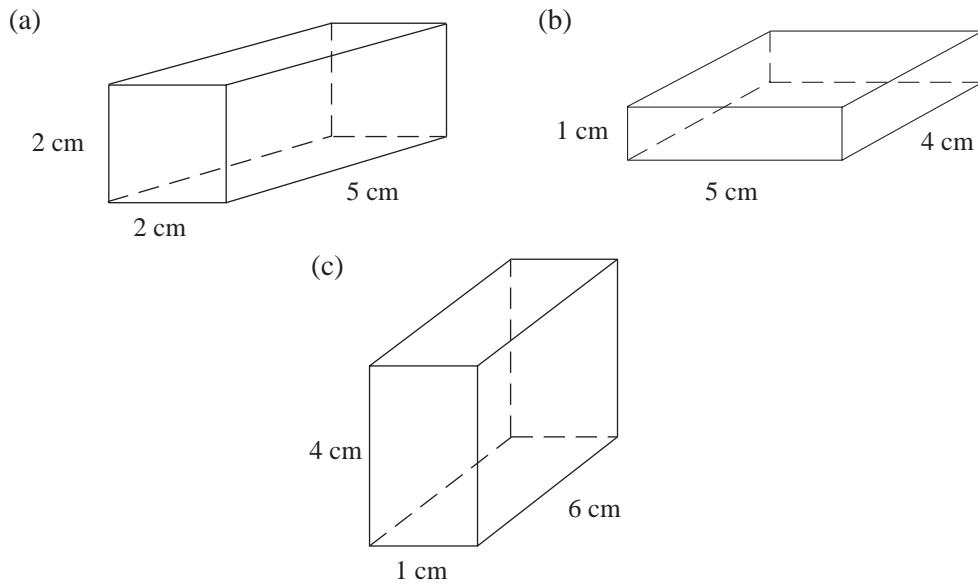

2. Draw accurate nets for each of the shapes below

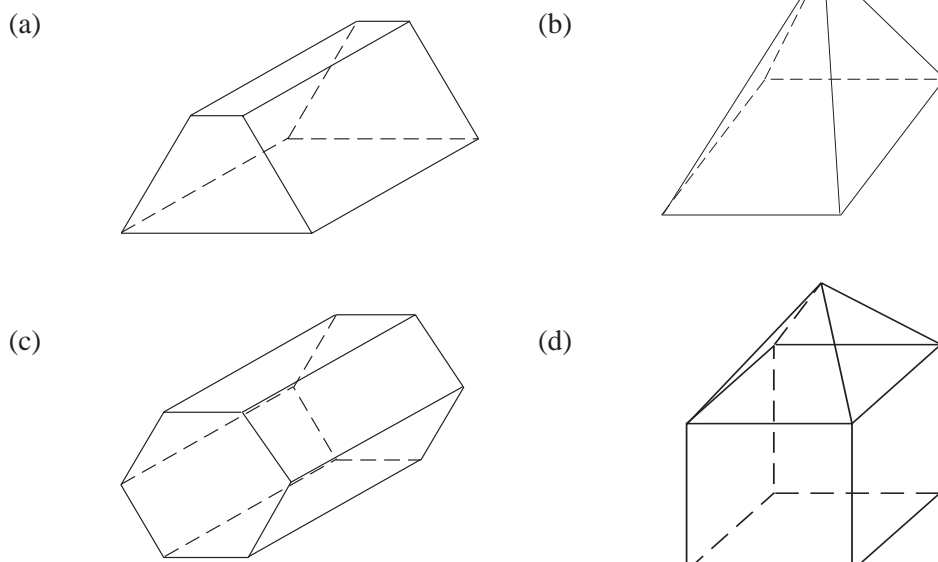

3. The diagrams below show some different ways in which 4 isosceles triangles (not equilateral) and 1 square can be arranged. Which could be nets for a square based pyramid ?

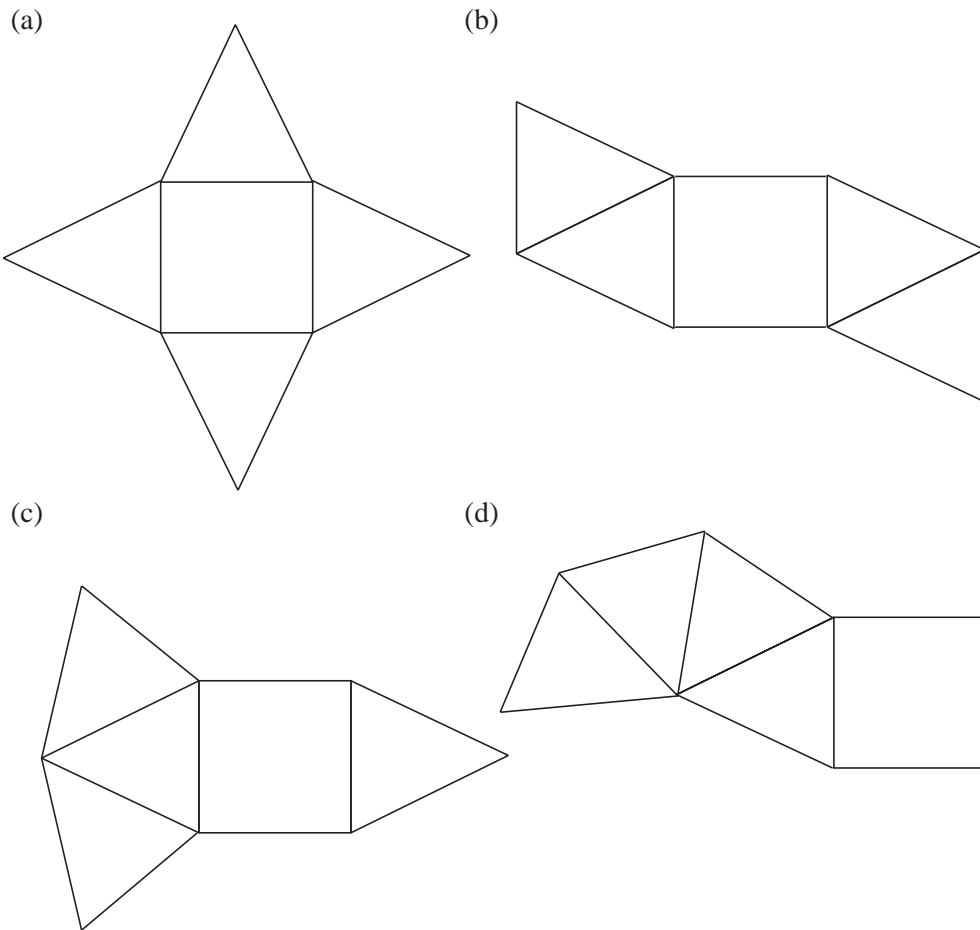

- 4.

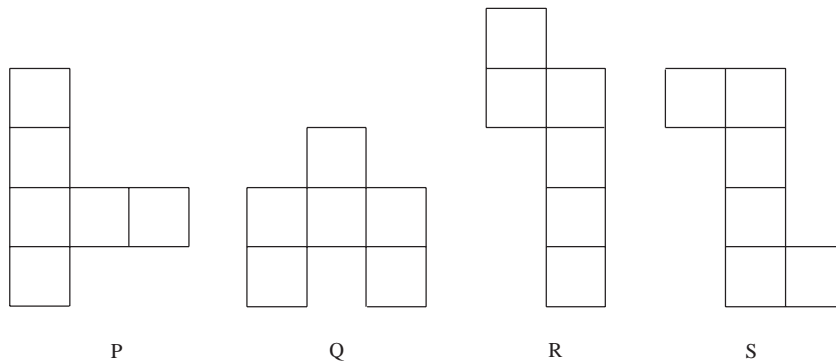

Which one of these nets can be folded to make a cube ?

(SEG)

5. The diagram shows a cuboid 4 cm by 2 cm by 1 cm.

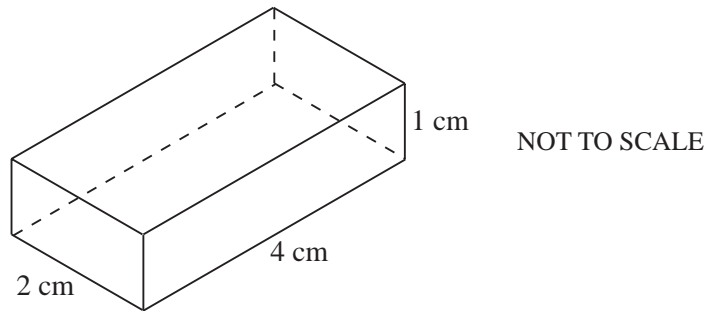

On a copy of the following centimetre grid, complete the net of the cuboid.

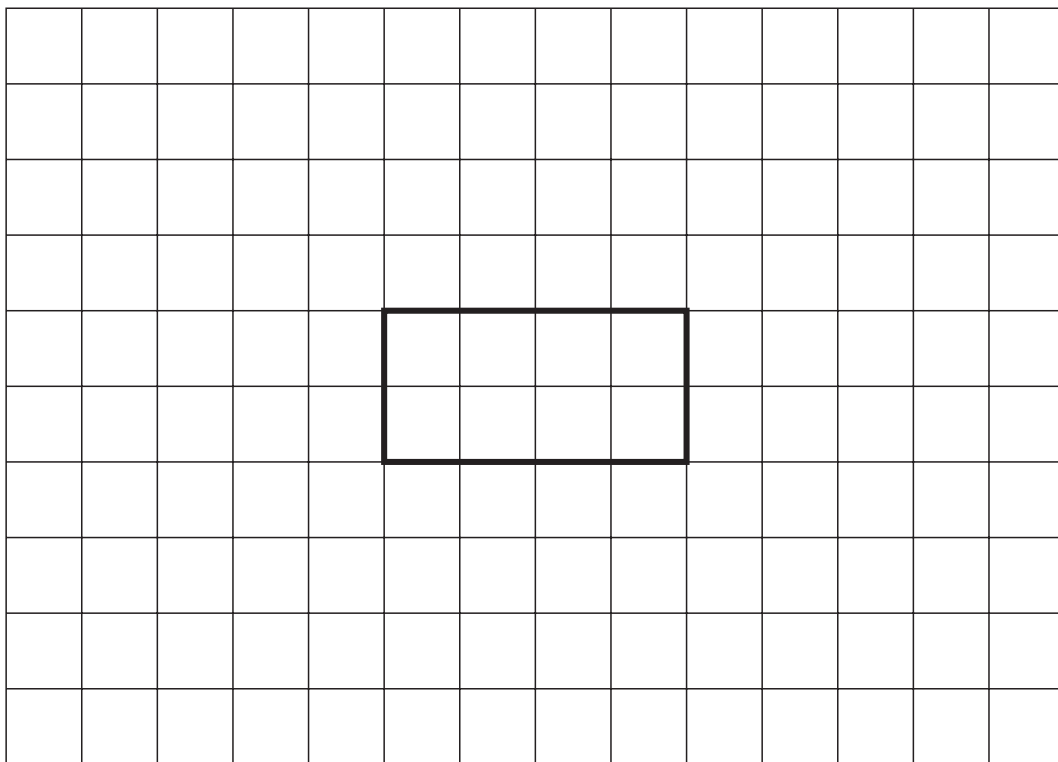

(AQA)

7.5 Conversion of Units

1. Convert each quantity to the units given
- | | |
|-------------------------|-------------------------|
| (a) 5 feet to inches | (b) 4 yards to feet |
| (c) 5 gallons to pints | (d) 72 inches to feet |
| (e) 4 stone to pounds | (f) 4 stone to ounces |
| (g) 56 pints to gallons | (h) 108 inches to yards |

2. Convert each quantity to the units given, giving your answer to an appropriate degree of accuracy.
- (a) 5 inches to cm
(b) 5 kgs to lbs
(c) 3 feet to cm
(d) 2 feet 4 inches to cm
(e) 15 gallons to litres
(f) 25 miles to km
(g) 120 kgs to stones
(h) 20 litres to pints
3. Convert each quantity to the units given. Give your answers to 1 d.p.
- (a) 6 km to miles
(b) 38 cm to inches
(c) 10 lbs to kgs
(d) 86 ounces to kgs
(e) 963 cm to feet
(f) 10 pints to litres
(g) 17 km to miles
(h) 7 stone to kgs
4. The table below gives the distance between towns in miles. Rewrite the table, with distances in km.

Exeter			
79	Bristol		
90	65	Southampton	
170	105	87	London

5. A car is travelling at a constant speed of 70 miles per hour. What is its speed in:
- (a) km per hour,
(b) m per hour,
(c) m per sec,
(d) cm per sec,
(e) feet per sec.
6. The heights of 5 girls in a class are:
- Sarah 1 m 32 cm
Jane 62 inches
Lucy 123 cm
Ann 4 feet 9 inches
Elaine 1 m 27 cm
- Put these girls in height order, tallest first.
7. A train travels 50 km and uses 250 litres of fuel. A second train uses 24 gallons of fuel to travel 15 miles. Find the fuel consumption of each train. Which one is most economic?

8. The same quantity can sometimes be measured in different units.

- (a) Fill in the missing unit in the statement below.
Choose the unit from this list:
millimetres, centimetres, metres, kilometres.

$$1 \text{ inch} = 2.54 \text{ _____}$$

- (b) Fill in the missing unit from the statement below.
Choose the unit from this list:
millilitres, litres, gallons, cubic metres.

$$4 \text{ pints} = 2.27 \text{ _____}$$

(MEG)

9. George calculates that his car does 35 miles per gallon of petrol.
Pierre calculates that his car does 9 kilometres per litre of petrol.

$$1 \text{ mile} = 1.61 \text{ kilometres} \quad 1 \text{ gallon} = 4.55 \text{ litres}$$

- (a) Calculate the petrol consumption of George's car in kilometres per litre.
(b) Calculate the difference in the petrol consumption of George's car compared with Pierre's car as a percentage of the petrol consumption of Pierre's car.

(SEG)

10. (a) Megan is 5 feet 3 inches tall.

$$1 \text{ cm} = 0.394 \text{ inches}$$

$$12 \text{ inches} = 1 \text{ foot}$$

Calculate Megan's height in centimetres.

Give your answer to an appropriate degree of accuracy.

- (b) An electronic weighing scale gives Megan's weight as 63.4792 kg.
Give her weight correct to an appropriate degree of accuracy.

(NEAB)

11. (a) When Lisa was on holiday in Spain she paid 138 pesetas for a glass of milk.
She knew that £1 = 193 pesetas and estimated that the milk cost 70 pence.
Show clearly, without using a calculator, how Lisa could have obtained her answer.

(b)

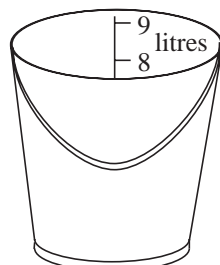

Bucket



Drinking glass

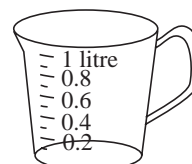

Jug

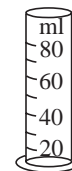

Measuring cylinder

Choose the most appropriate container from the four pictured above to measure

- (i) the amount of milk used in a cup of tea,
(ii) the amount of water in a garden pond.

(MEG)

7.6 Squares, Rectangles and Triangles

1. Find the area of each of the following shapes:

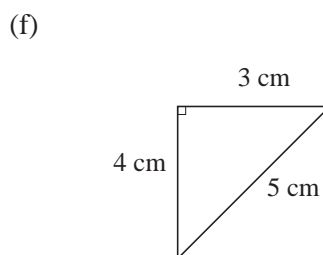
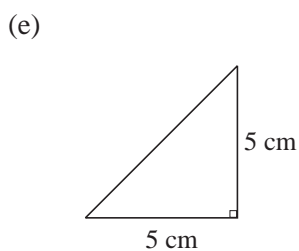
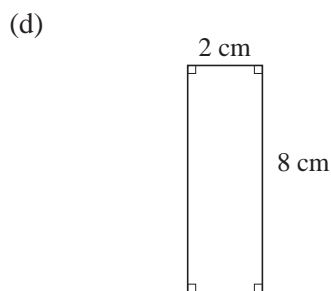
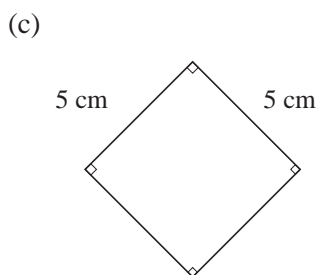
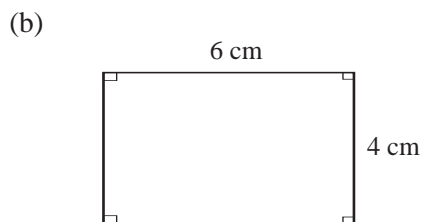
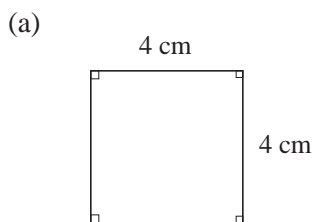

2. Find the area of the triangle PQR in the following cases:

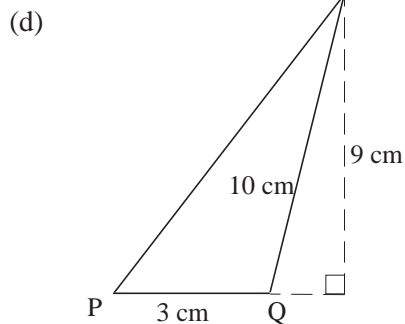
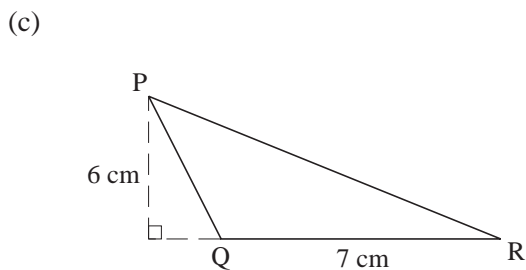
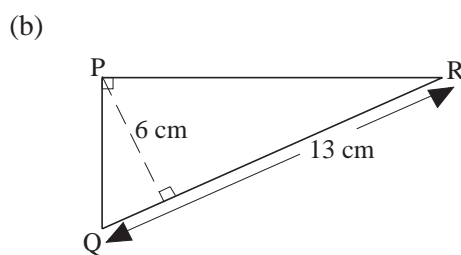
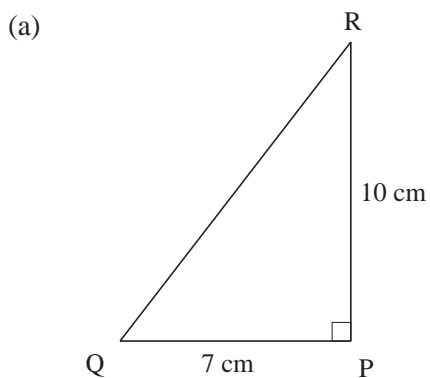

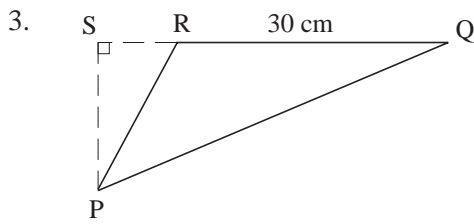

In the diagram the area of ΔPQR is 255 cm^2 and the length of QR is 30 cm . Find the length of PS .

4. Find the base of each triangle when:

	<i>Area</i>	<i>Height</i>
(a)	6 cm^2	4 cm
(b)	20 cm^2	5 cm
(c)	100 mm^2	25 mm
(d)	48 m^2	160 cm

5. Copy and complete the table below for each given rectangle

	<i>Length</i>	<i>Breadth</i>	<i>Perimeter</i>	<i>Area</i>
(a)	6 m	4 m		
(b)	8 m			48 cm^2
(c)		2.2 m		8.8 cm^2
(d)	4.5 m		23 m	
(e)		26 mm	98 mm	

6. Find the areas of the shaded regions. All dimensions are in cm.

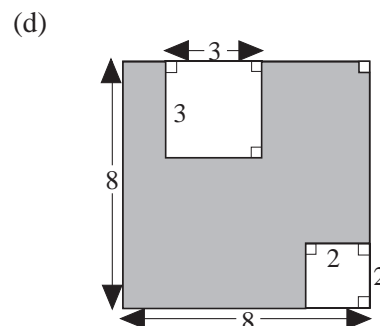
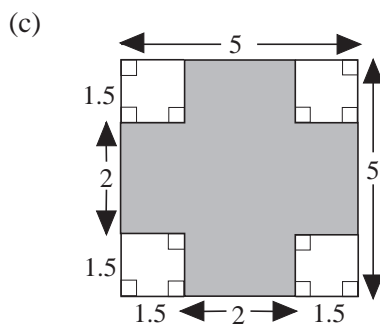
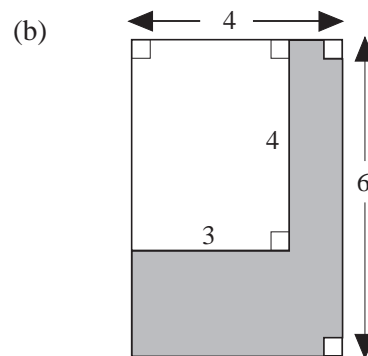
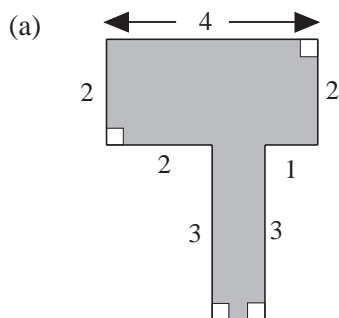

7. A wedding photograph measures 250 mm by 150 mm and is mounted on a frame 300 mm by 200 mm. Find the area not covered by the photograph.

8. The wall of a room has one window. The diagram shows the dimensions of the wall and window.

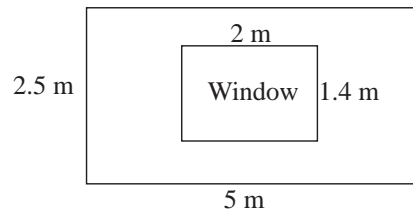

- (a) Find the area of wall;
- (b) If it costs £2 per m^2 for painting, how much will it cost to paint the wall?

9. Find the number of 15-centimetre square tiles required to cover a floor 5.4 m long and 4.05 m wide.

10. Find the area, in square centimetres, of a rectangular strip of board 3.28 m long and 75 mm wide.

11. A square cardboard of side 20 m has a 4 m wide border round three of its sides. Find the area of the border.

12. A paper box without a lid is 25 cm long, 16 cm wide and 5 cm deep. How many square centimetres of paper have been used to make the box ?

13. Find the area of each of the following shapes:

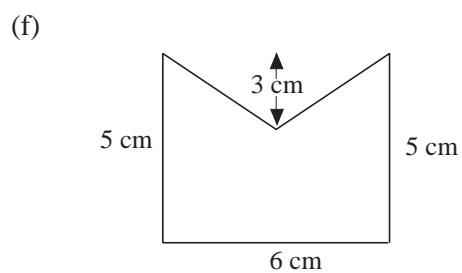
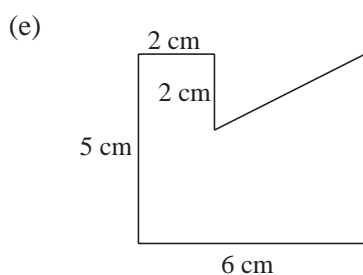
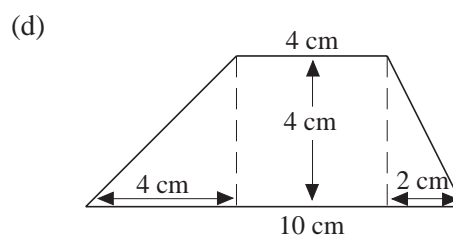
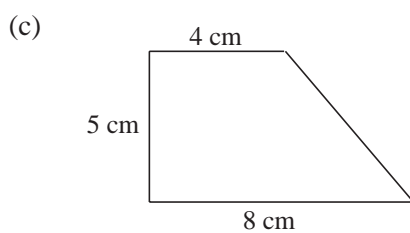
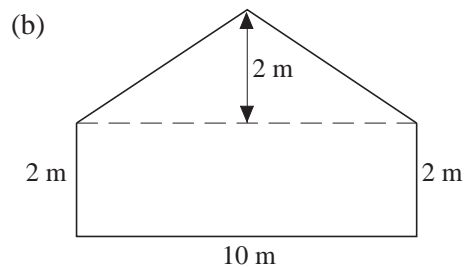
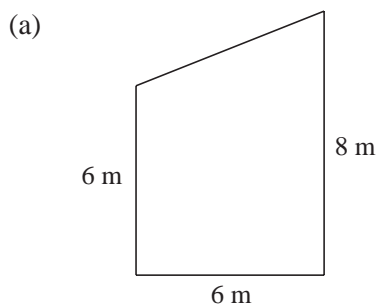

14. The shaded square has sides of length 1 cm.
It is enlarged a number of times as shown.

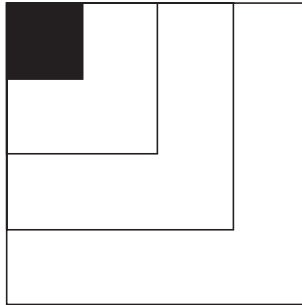

- (a) Complete the table.

<i>Length of side of square</i>	1 cm	2 cm	3 cm	4 cm
<i>Perimeter of square</i>	4 cm	8 cm	12 cm	
<i>Area of square</i>	1 cm ²	4 cm ²		16 cm ²

The shaded square continues to be enlarged.

- (b) Complete the following table.

<i>Length of side of square</i>	
<i>Perimeter of square</i>	
<i>Area of square</i>	64 cm ²

(SEG)

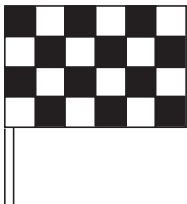
15. (a)  The area of each small square on the chequered flag is 64 cm².
What is the area of the flag

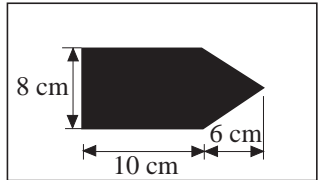
- (b)  NOT TO SCALE

The design on this flag consists of a rectangle and a triangle.

Calculate the area of the design

(NEAB)

16. Debbie wants to make a rectangular paved area in her garden. She uses 36 square paving tiles. One possible arrangement is shown.

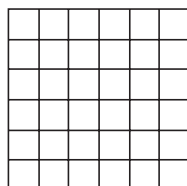

NOT TO SCALE

Each tile is 50 cm by 50 cm.

- (a) What is the perimeter of this arrangement? Give your answer in metres.
- (b) Four other rectangular paved areas can be made from the 36 tiles.
One of the other areas is 9 by 4.
Note that a rectangle 9 by 4 is the same as one 4 by 9.
Write down in the table the length and breadth of each of the remaining three of these rectangles.

<i>length</i>	6	<i>breadth</i>	6
<i>length</i>	9	<i>breadth</i>	4
<i>length</i>		<i>breadth</i>	
<i>length</i>		<i>breadth</i>	
<i>length</i>		<i>breadth</i>	

(SEG)

17. Terry is told to draw four different rectangles, each with a perimeter of 18 cm. He draws these shapes.

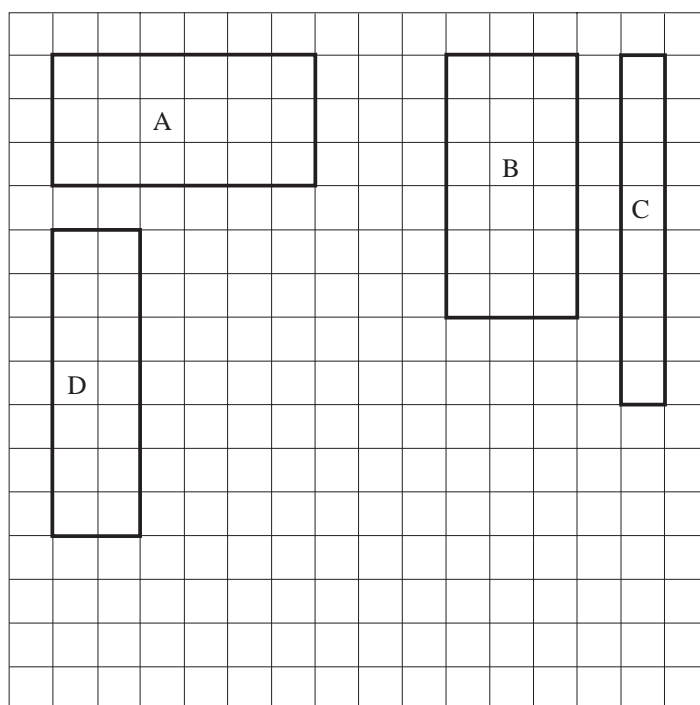

- (a) His teacher says two of these are really the same. Which two?
 - (b) What is the mathematical name given to two shapes which are exactly the same?
 - (c) On the grid draw another rectangle with a perimeter of 18 cm which is not exactly the same as A, B, C or D.
 - (d) What is the area of rectangle D?
- (SEG)

18. A farmer plans to fence off a rectangular part of a field using fence panels. The width of each panel is 1m.

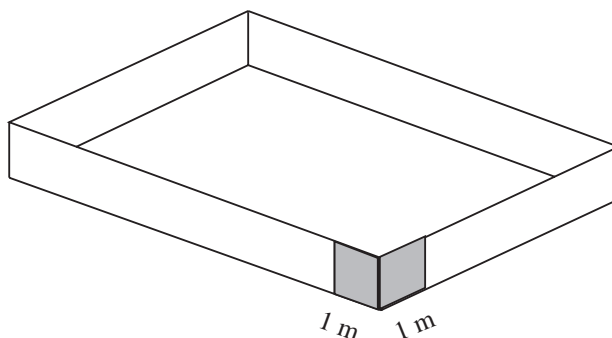

He needs to fence off an area of 50 m^2

- (a) One rectangle he can fence off is 5 m by 10 m.

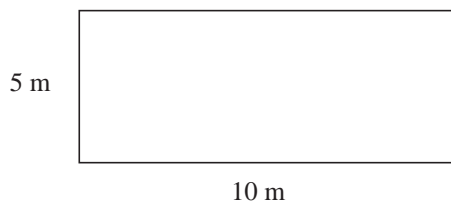

Not to scale

- (i) Write down the dimensions of the other two rectangles he can make, each with an area of 50 m^2 .
- (ii) Which rectangle uses the smallest number of panels?

The farmer changes his mind because he wants to use fewer panels. He decides to use an existing wall for one side of the rectangle, and fence panels for the other three sides.

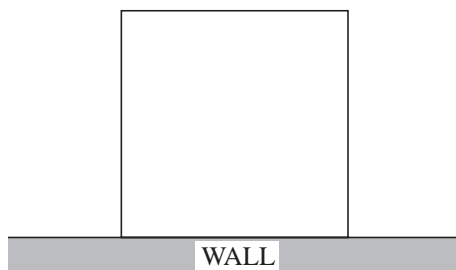

Not to scale

- (b) What is the smallest number of panels he can now use to make an area of 50 m^2 ?

(SEG)

19.

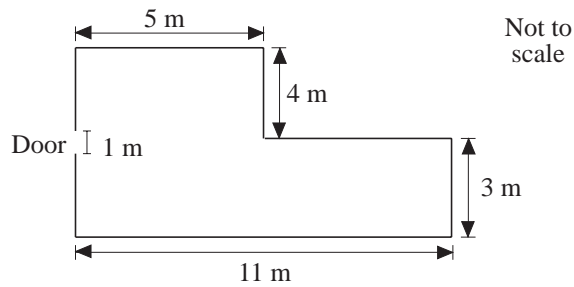

The diagram shows the plan of the floor of a room.

- Calculate the perimeter of the room.
- Wooden skirting board is fitted around the perimeter, but not across the doorway.
It costs 83 p per metre.
Calculate the cost of the skirting board needed for this room.
- Calculate the area of the floor of the room.
- Carpet tiles measure 1 m by 1 m.
They are sold in boxes each containing 12 tiles.
Each box costs £103.50.
 - How many boxes are needed to carpet this floor area?
 - What is their total cost?

(MEG)

20. (a) A shaded rectangle is drawn on a centimetre square grid.

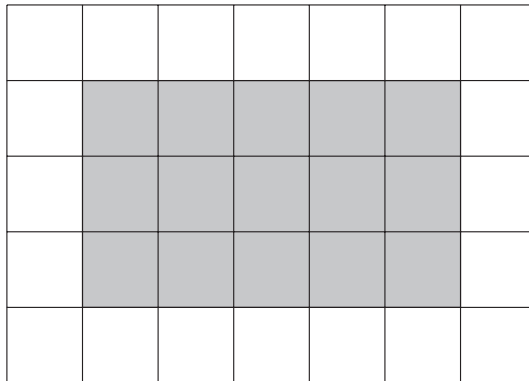

Work out the area of the shaded rectangle.
State the units of your answer.

- (b) On a copy of the centimetre square grid below draw a rectangle with a **perimeter** of 10 cm.

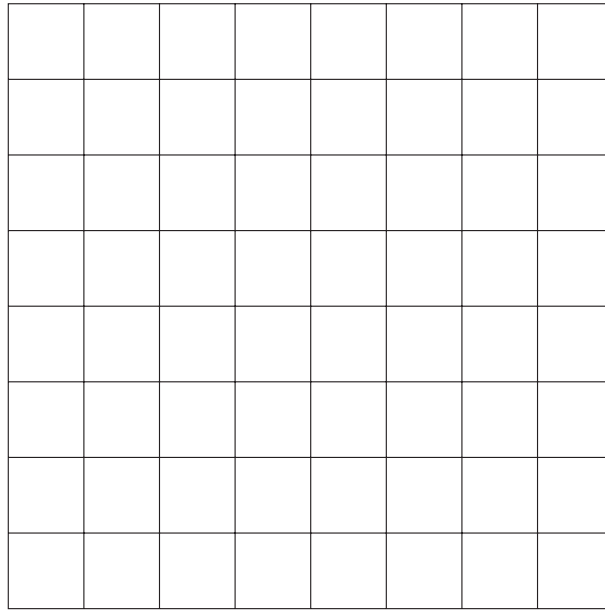

(AQA)

21. The diagram shows the plan of a floor.
There is a carpet in the middle of the floor.

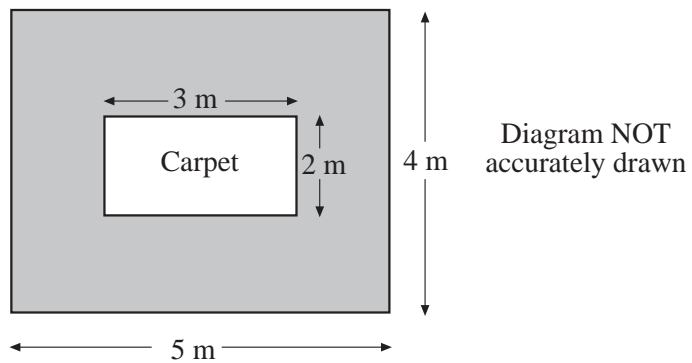

Work out the shaded area. Write down all the stages in your working.

(Edexcel)

22. The diagram shows the side wall of a building.

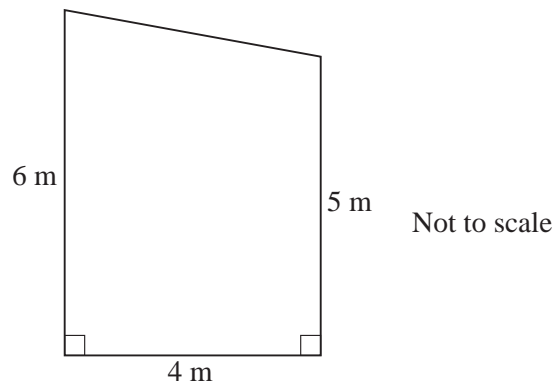

Calculate the area of the wall.

You **must** show all your working.

(AQA)

6. Find the areas of the shaded regions, given that O is the centre of each circle.

(a)

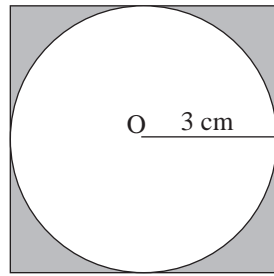

(b)

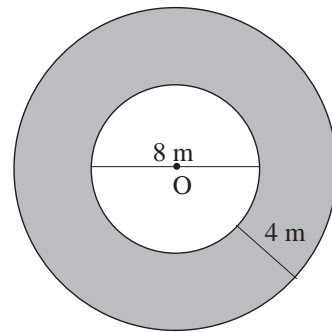

7. Find the perimeter and area of each of the following figures. All dimensions are given in cm and the circular portions are semicircles.

(a)

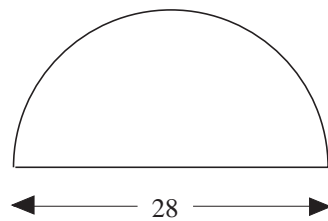

(b)

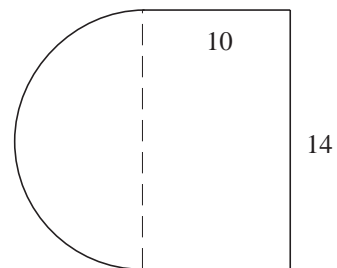

(c)

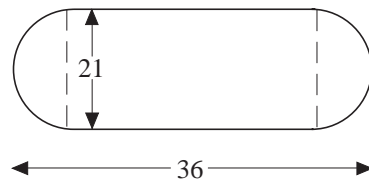

(d)

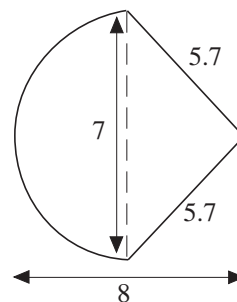

(e)

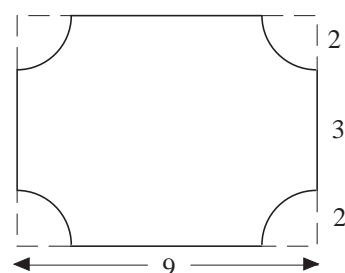

(f)

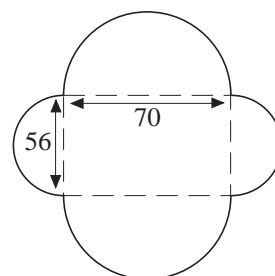

8. Two wire circles of diameters 12 cm and 8 cm are cut and then joined to make one large circle. Find the diameter of this larger circle.
9. A bicycle wheel has a radius of 30 cm.
- Find the circumference of the wheel.
 - How far does the bicycle go in 100 turns of the wheel? Give your answer in m.

10. Find the perimeter and area of each of the shaded regions. Take $\pi = 3.14$ and give your answers correct to 3 significant figures. All measurements are in centimetres (cm).

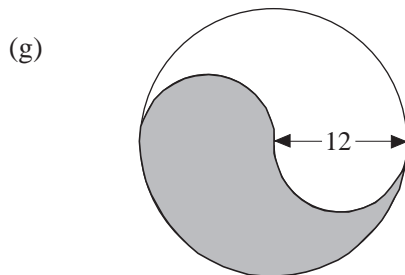
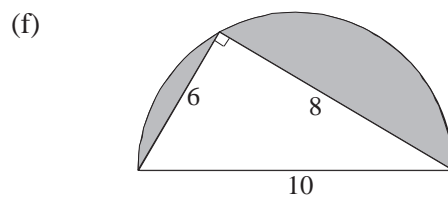
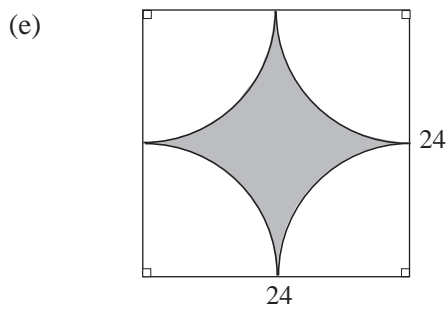
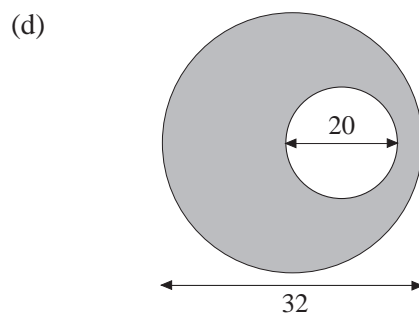
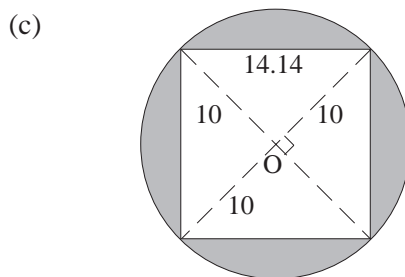
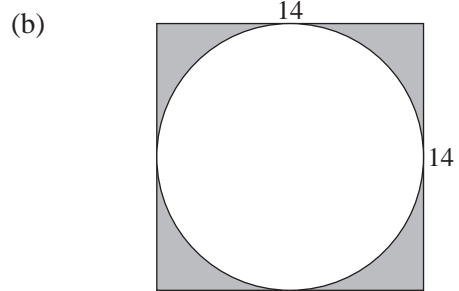
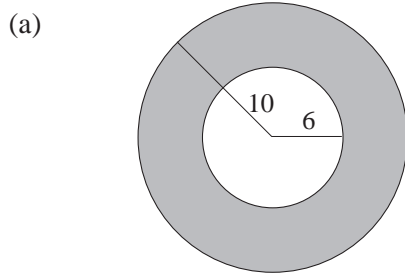

11. A cardboard party plate has a diameter of 22 cm.

Not to scale

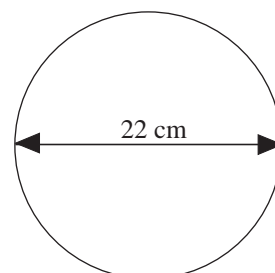

- (a) Calculate the circumference
Take π to be 3.14 or use the π key on your calculator.
- (b) (i) What is the radius of the plate?
(ii) Calculate the area of the plate correct to the nearest whole number.
(SEG)

12. The diagram shows a regular hexagon.
The point X is the centre of the hexagon.

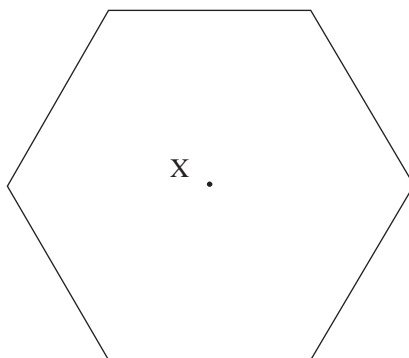

- (a) (i) Measure and write down the length of one side of the hexagon.
(ii) Calculate the perimeter of the hexagon.
- (b) (i) Draw a circle, centre X, which passes through the six vertices of this hexagon.
(ii) Write down the length of the radius of your circle.
- (c) Use the diagram to explain why the circumference of the circle is greater than the perimeter of the hexagon.
- (d) Calculate the circumference of the circle you have drawn.
(NEAB)

13. (a) A circle has a radius of 4 cm. Write down the length of the diameter.
- (b) On a copy of the circle below,
(i) draw a diameter
(ii) mark with a cross a point on the circumference
(iii) draw a tangent.

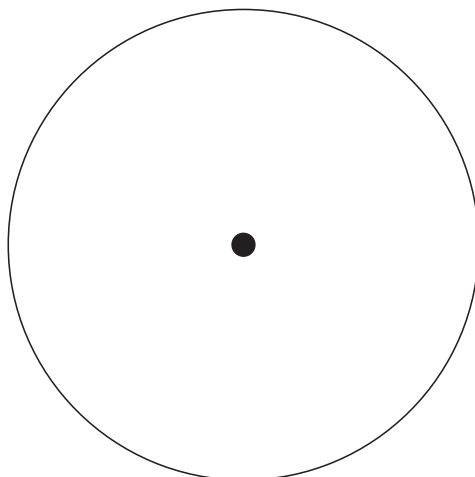

(AQA)

14. A circle fits inside a semicircle of diameter 10 cm as shown.

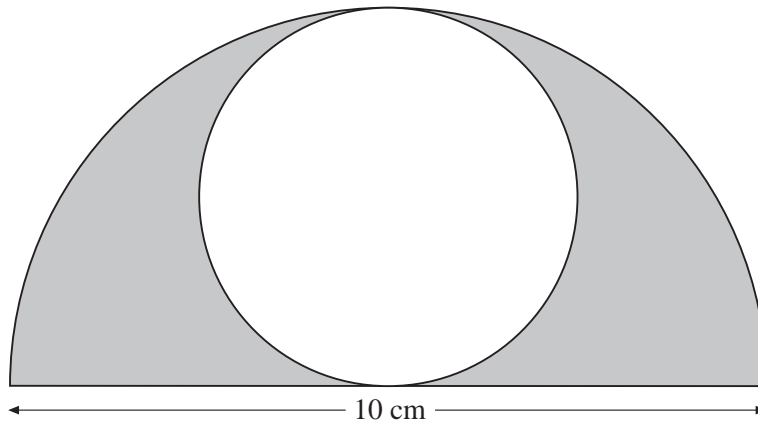

Not drawn accurately

Calculate the shaded area.

(AQA)

15. A giant paper clip is placed alongside a centimetre ruler. The curved ends are semicircles.

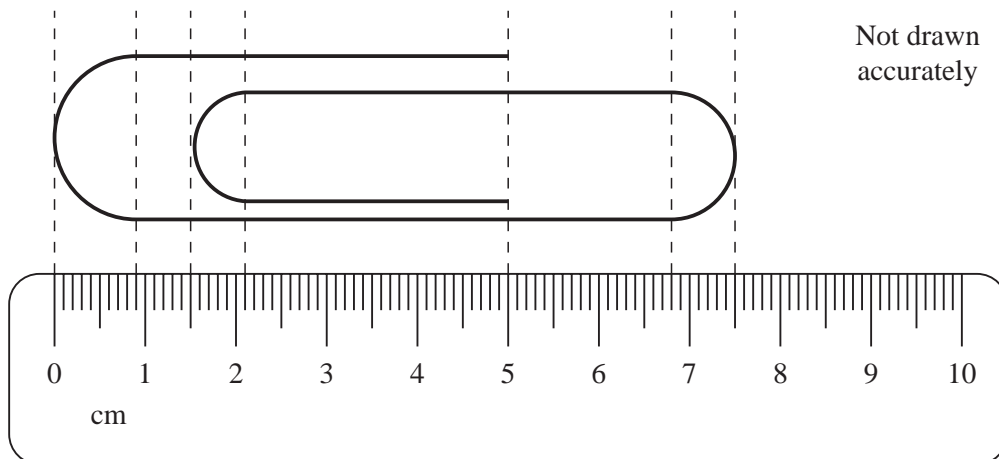

Not drawn accurately

Calculate the length of wire used to make the clip.

(AQA)

7.8 Volumes of Cubes, Cuboids, Cylinders and Prisms

1. Find the volume of each shape shown below.

(a)

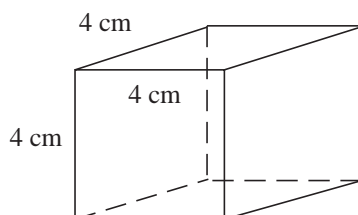

(b)

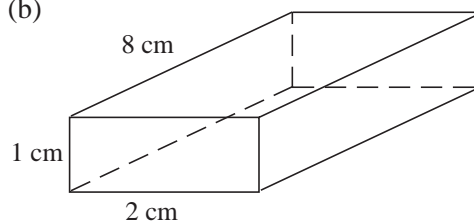

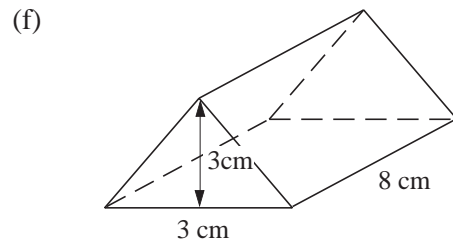
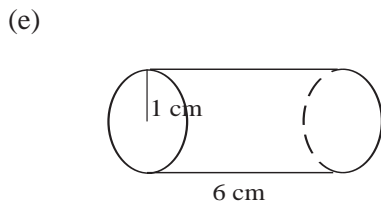
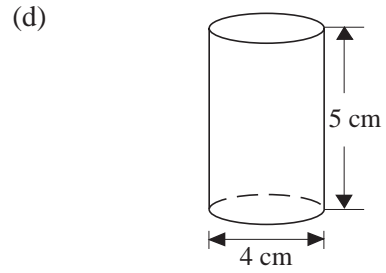
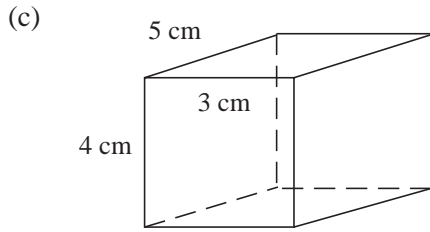

2. Find the volume of each prism below.

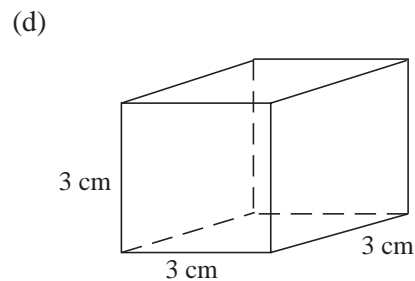
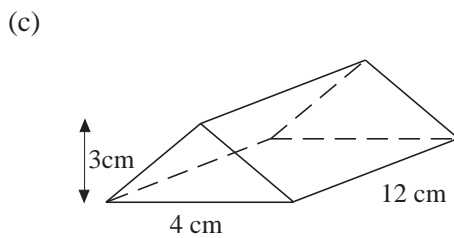
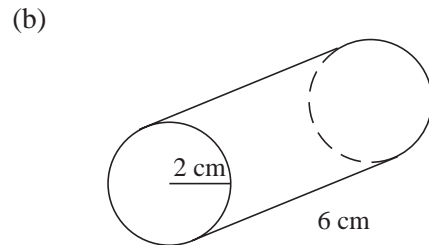
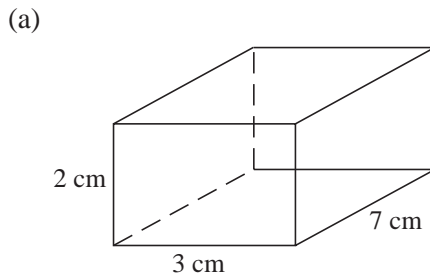

3. Find the volume of each prism below.

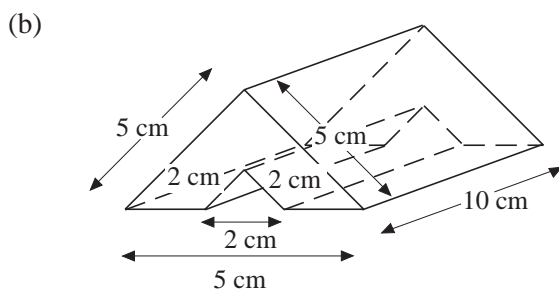
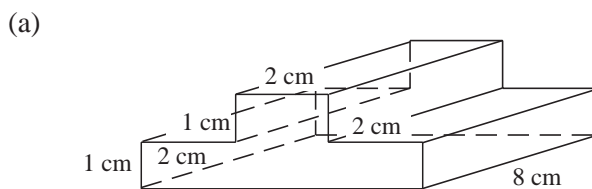

4. Quickgrow fertiliser is packed in cylindrical drums.

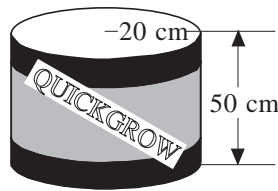

Not to scale

- (a) One size of drum has a radius of 20 cm and a height of 50 cm.
- Calculate the area of the base of this drum.
Take π to be 3.14 or use the π key on your calculator.
 - Calculate the volume of this drum.
- (b) Another size of cylindrical drum has a **volume** of $100\,000\text{ cm}^3$ and a height of 40 cm. Calculate the radius of this drum.

(SEG)

5. A cylindrical can has a radius of 6 centimetres.

- (a) Calculate the area of the circular end of the can.
(Use the π button on your calculator or $\pi = 3.14$)

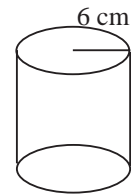

The capacity of the can is 2000 cm^3 .

- (b) Calculate the height of the can.
Give your answer correct to 1 decimal place.

(LON)

6. A cylindrical pencil holder is shown.

The height is 15 cm and the diameter 6 cm.

- (a) What is the capacity of the pencil holder?
- (b) The outer curved surface area is covered with coloured paper.
What is the area of the paper?

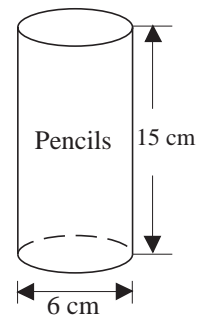

(SEG)

7. Jack makes some concrete steps. The diagram shows their dimensions in centimetres.

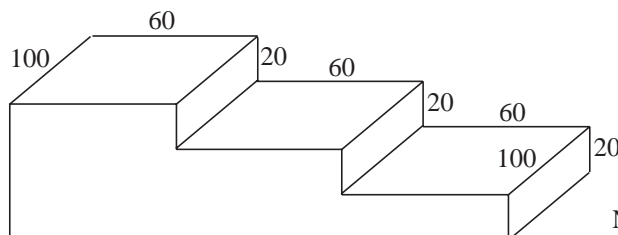

Not to scale

- (a) Calculate, in cubic centimetres, the volume of concrete needed.
- (b) There are $1\,000\,000\text{ cm}^3$ in 1 m^3 . Change your answer to (a) into m^3 .

(SEG)

8. A pencil is in the shape of a regular hexagonal prism as shown. The pencil consists of a cylinder of graphite and a wooden surround. O is the centre of the circular end of the graphite. The diameter of the circle is 2 mm. ED = 4 mm. DG = 18 cm.

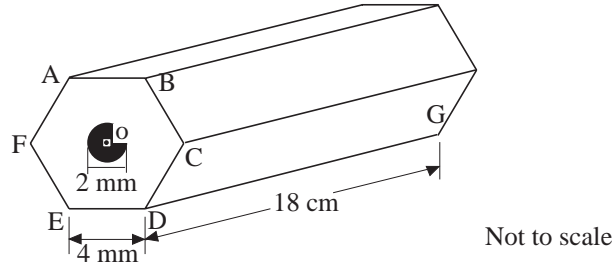

- Find the size of angle AOB.
 - Calculate the area of the regular hexagon ABCDEF.
 - Calculate the area of the circle.
Take π to be 3.14 or use the π key on your calculator.
 - Calculate the volume of wood in one pencil.
- (SEG)
9. Tennis balls are sold in boxes of three. The balls fit tightly inside the box.

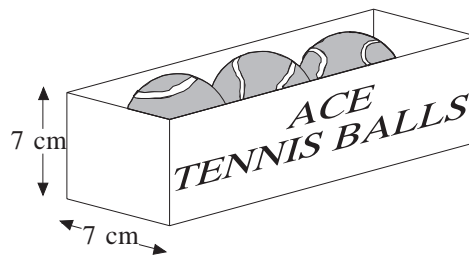

- Calculate the length of the box.
 - Calculate the volume of the box.

The tennis balls do not fill all the space inside the box.
 - Give a rough estimate for the volume of one tennis ball. Show your working.
- (SEG)
10. Evelyn buys a special offer packet of biscuits marked 20% extra free. It contains 20% more biscuits than a normal packet for the same price.

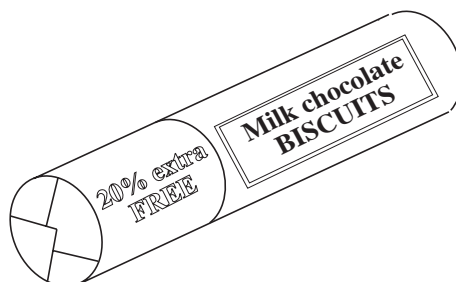

The normal packet weighs 250 g.

- (a) What is the weight of the special offer packet?

The special offer packet of biscuits is a cylinder with radius 3 cm and length 18 cm.

- (b) Calculate the volume of a special offer packet.
Take π to be 3.14 or use the π key on your calculator.
- (c) The normal packet is also a cylinder.
What is the volume of a normal packet?

(SEG)

11. (a) Christopher buys a fish tank.
The dimensions of the tank are 91 cm by 32 cm by 35 cm.

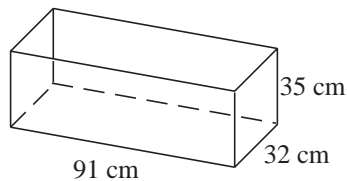

- (i) Calculate the volume of the tank in cm^3 .
- (ii) How many litres of water will the tank hold when full?
($1000 \text{ cm}^3 = 1 \text{ litre}$)
- (b) Christopher bought the tank from a pet shop.
He had a choice of four different sizes of tank.

PETS GALORE
TANKS NOW IN STOCK
2 feet, 3 feet, 4 feet or 5 feet

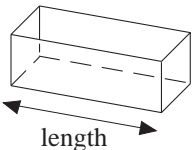

These sizes are the lengths of the tanks

Which size of tank did Christopher buy?

- (c) Christopher needs to put 50 litres of water into the tank.
He wants to know how deep the water will be in centimetres.
To do this he needs to work out this calculation:

$$\frac{50 \times 1000}{91 \times 32}$$

The answer he gets on his calculator is 17582.418.
This answer is wrong.

- (i) What mistake did he make when he worked this out?
- (ii) What is the correct answer?

(NEAB)

12.

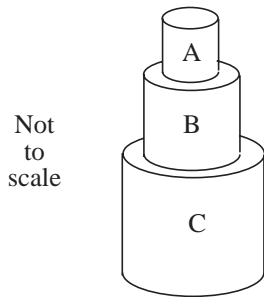

A child builds a tower from three similar cylindrical blocks.

The smallest block, A, has radius 2.5 cm and height 6 cm.

- (a) Find the volume of the smallest box.
- (b) Block B is an enlargement of A and block C is an enlargement of B, each with a scale factor of $1\frac{3}{4}$.
Find the total height of the tower.

(MEG)

13. (a) This cuboid is made from 1 centimetre cubes.
What is its volume?

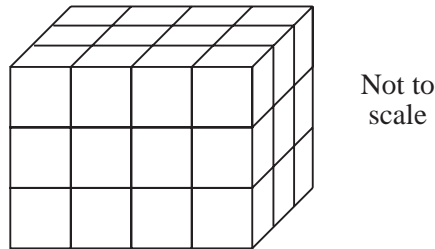

- (b) Calculate the volume of this cuboid.

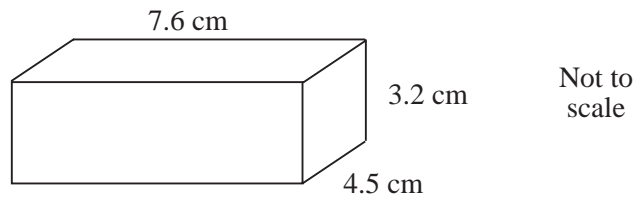

(OCR)

14.

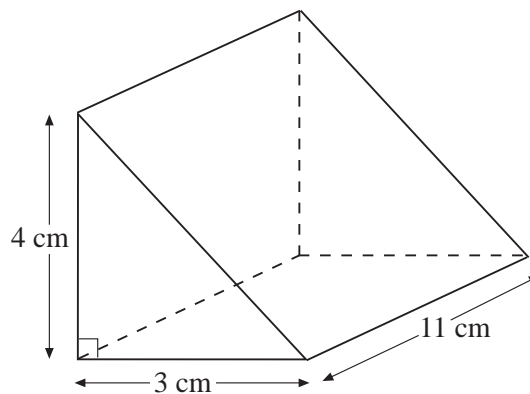

Work out the volume of the triangular prism.

Give the units with your answers.

(Edexcel)

15. The diagram shows a cylinder.
The diameter of the cylinder is 10 cm.
The height of the cylinder is 10 cm.

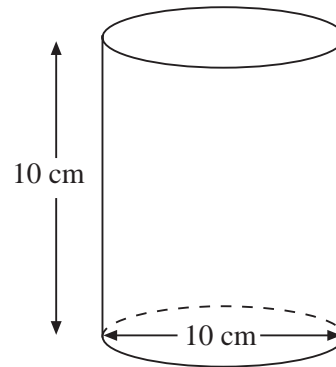

- (a) Work out the volume of the cylinder.
Give your answer in terms of π .
- (b) Twenty of the cylinders are packed in a box of height 10 cm.
The diagram shows how the cylinders are arranged inside the box.
The shaded area is the space between the cylinders.

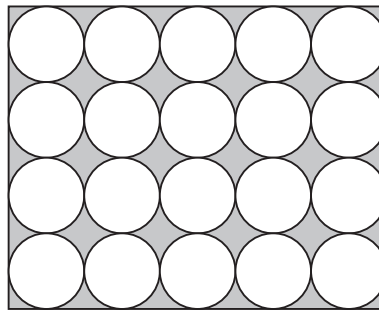

Not drawn
accurately

Work out the volume inside the box that is **not** filled by the cylinders.
Give your answer in terms of π .

(AQA)

7.9 Plans and Elevations

1. Draw the plan, front elevation and side elevation for each solid shown below.

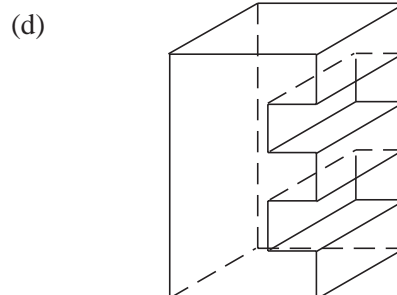
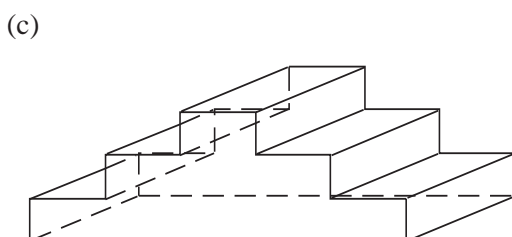
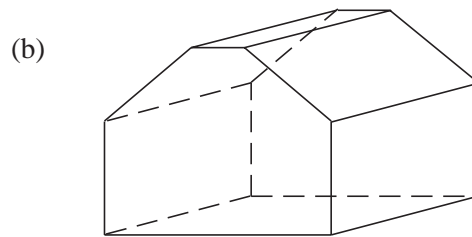
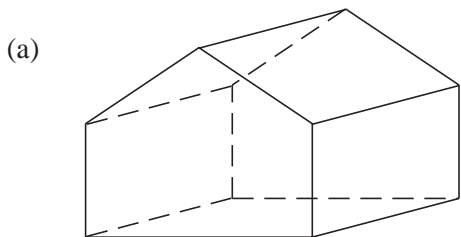

2. Draw a plan and front elevation for:

- (a) a lampshade,
- (b) a cricket bat,
- (c) a pencil,
- (d) a ring doughnut.

3. Draw the plan, front and side elevation for:

(a)

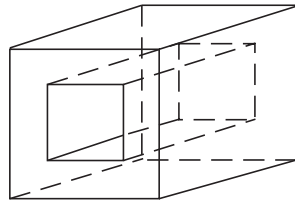

(b)

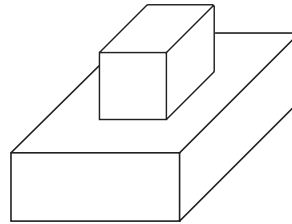

4. Part of a net of a cuboid has been drawn on the grid.

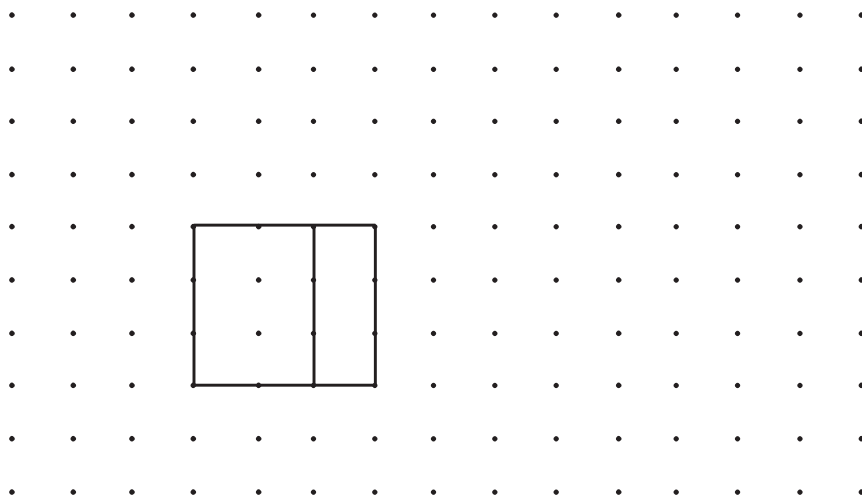

- (a) Complete accurately this net.
- (b) Write down the length, width and height of the cuboid which can be made from this net.
- (c) The net in the diagram is a scale drawing of a net of a cereal packet. The scale is 1 cm to 5 cm.

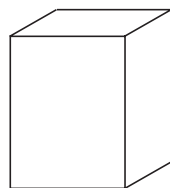

- (i) Write down the length, width and height of the cereal packet.
 - (ii) Calculate the area of cardboard needed to make the cereal packet, without flaps.
- (d) Calculate the volume of the cereal packet.

- (e) Some other boxes have dimensions 4 cm by 10 cm by 30 cm. They are packed into a carton with dimensions 48 cm by 80 cm by 60 cm.

Can boxes of this size be fitted exactly into the carton, with no space wasted?

Show calculations to explain your answer.

(SEG)

5. The drawing shows a cuboid with a prism removed. The measurements are in centimetres.

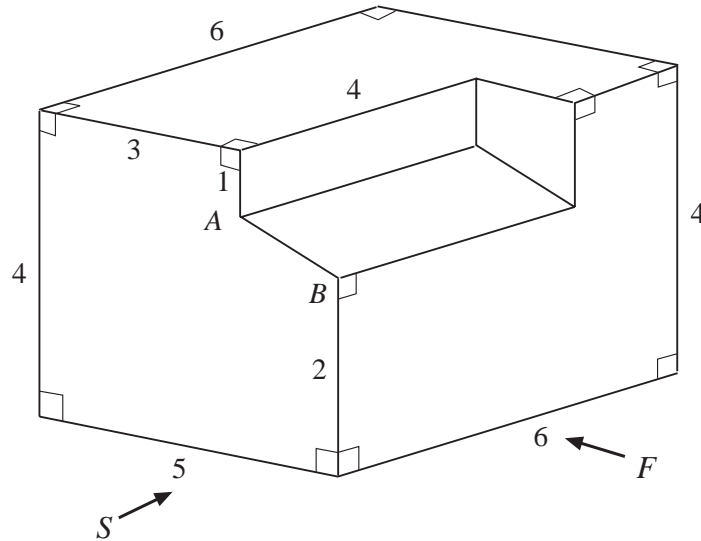

- (a) On a copy of the grid, draw full size the front (F) and side (S) elevations.

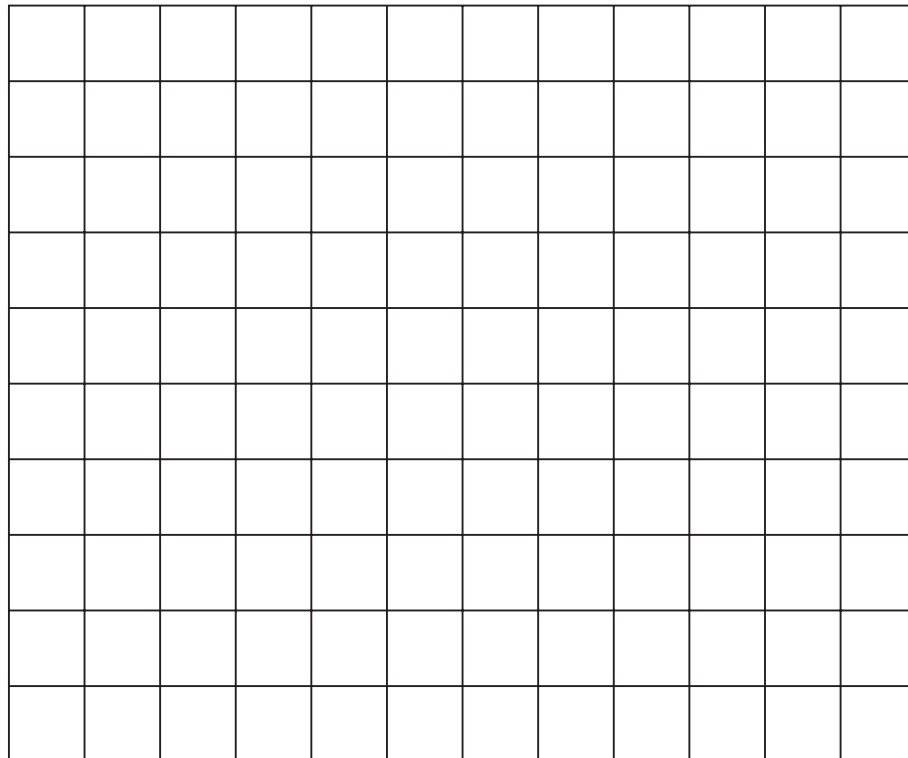

- (b) What is the length of the sloping edge marked AB on the drawing?

(OCR)

6. Here are the plan, front elevation and side elevation of a 3-D shape.

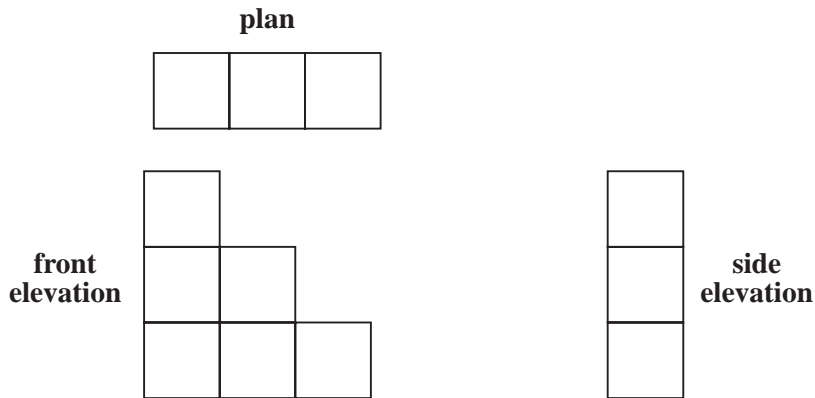

- (a) Draw a sketch of the 3-D shape.

Here is a sketch of a different 3-D shape.

The shape is a cylinder with a cone on top.

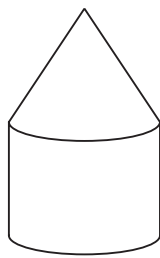

Diagram NOT accurately drawn

- (b) Sketch the front elevation of this 3-D shape.

(Edexcel)

7.10 Using Isometric Paper

- On isometric paper draw the following cuboids:
 - sides of length 3 cm, 3 cm and 5 cm,
 - sides of length 2 cm, 3 cm and 4 cm.
- On isometric paper, draw a garage which has a sloping roof.
- In each case below, the plan and two elevations of a solid are given. Draw an isometric drawing of each solid.

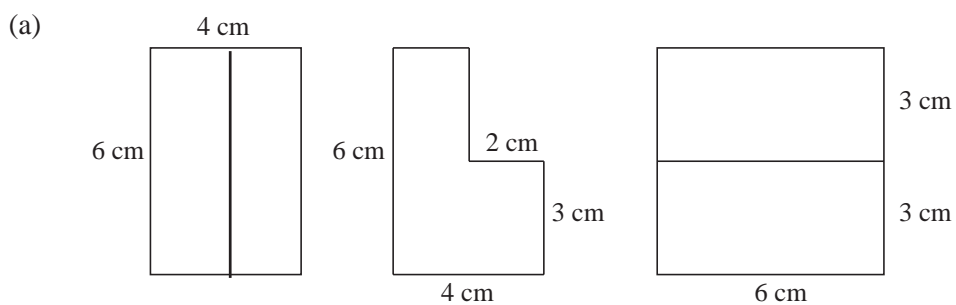

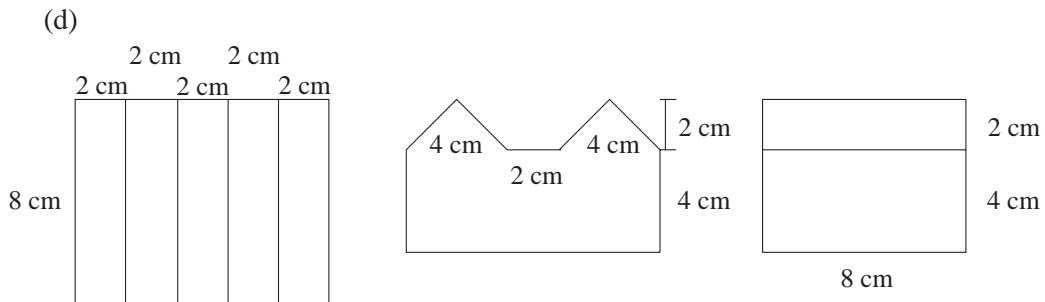
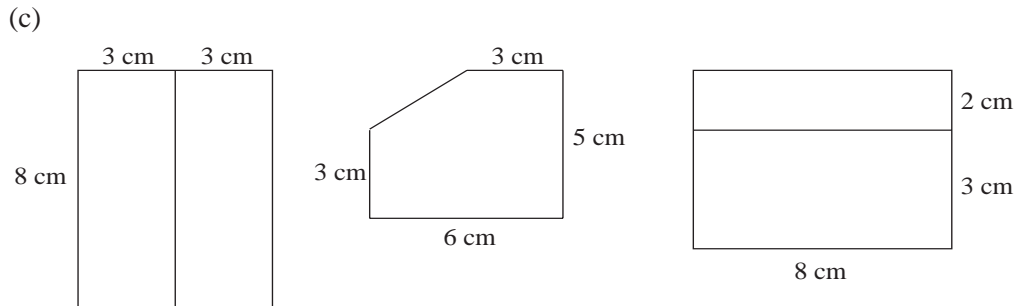
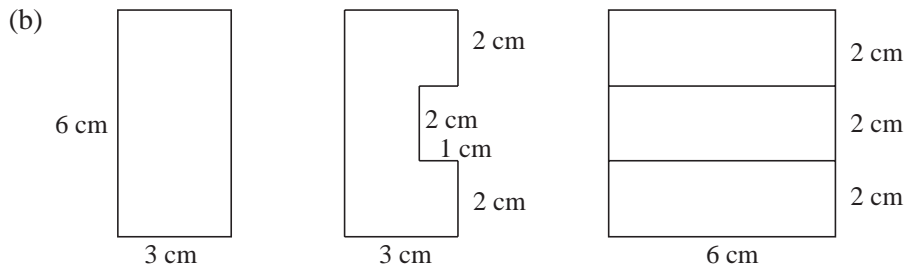

7.11 Discrete and Continuous Measures

- State whether each of the following is discrete or continuous.
 - no. of goals scored in a football match,
 - the length of a human foot,
 - the number of teachers in your school,
 - the time it takes to travel to London,
 - the number of players in a tennis tournament,
 - the weight of your school bag,
 - the number of rabbits in the country.
- In each case state whether the value given is exact or give the range of values in which it could lie.
 - Shoe size is $6\frac{1}{2}$.
 - The radius of the earth is 3866 km.
 - The cost of a shirt is £5.99.
 - A newspaper has 64 pages.
 - The capacity of a bus is 73 people.

- (f) The weight of the contents of a tin of baked beans is 220 grams.
 (g) 486 people voted for the Monster Raving Loony party.
 (h) The volume of a drink is 0.175 litres.

7.12 Areas of Parallelograms, Trapeziums, Kites and Rhombuses

1. Find the area of each of the following shapes:

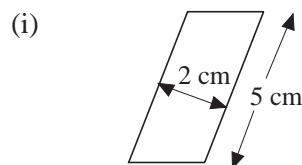
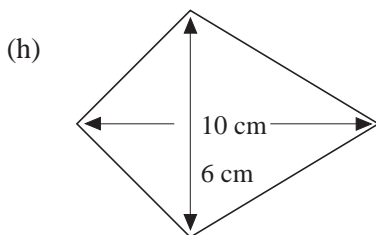
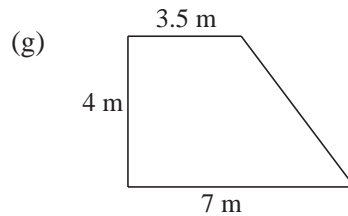
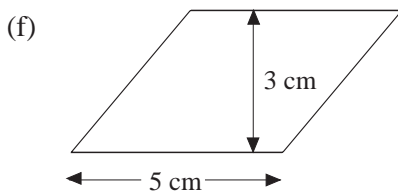
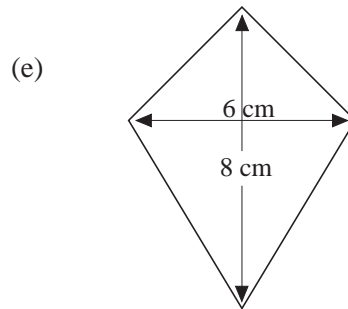
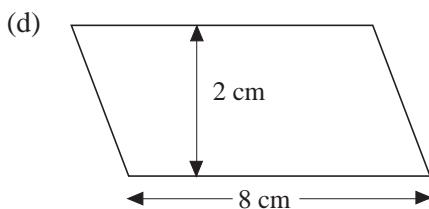
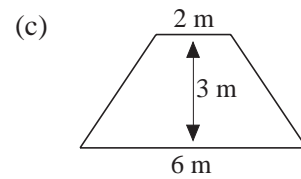
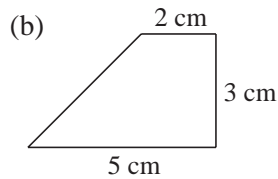
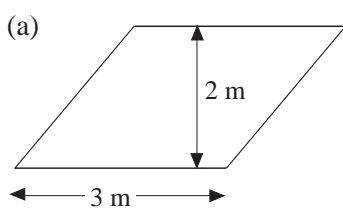

2. Find the areas of the following parallelograms:

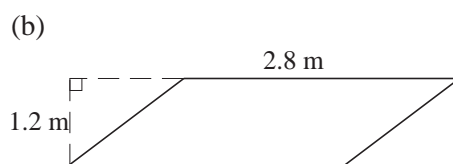
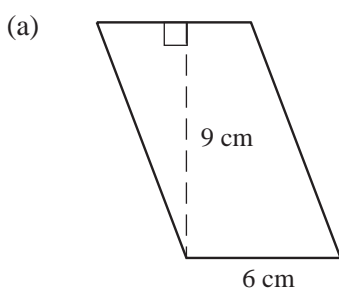

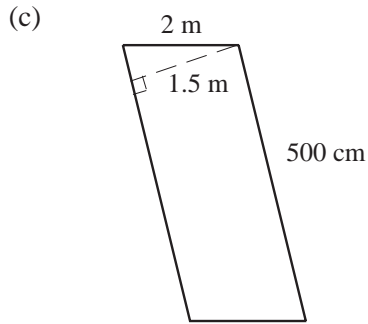

(Give your answer in m^2)

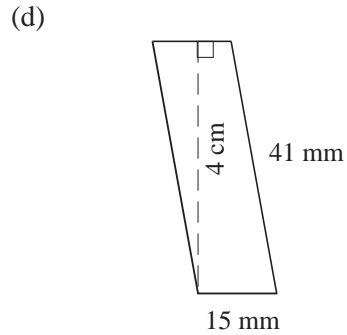

(Give your answer in mm^2)

3. Find the base of a parallelogram, given that its height is 8 cm and its area 64 cm^2 .
4. The area of a parallelogram is 108 mm^2 . Find its height if the base is 12 mm.
5. Find the area of the trapezium. Give your answer in cm^2 .

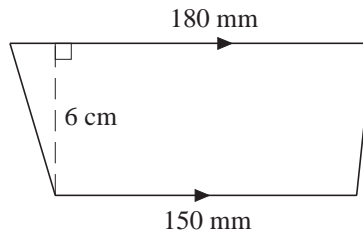

6. Find the area of the trapezium. Give your answer in mm^2 .

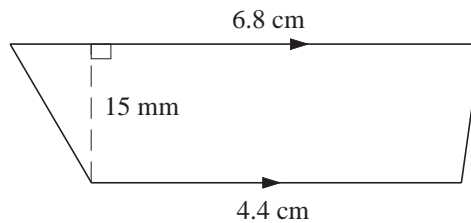

7. A trapezium has an area of 120 cm^2 . Its parallel sides measure 14 cm and 10 cm. Find its height.
8. A trapezium has a height of 8 m. What is the sum of its parallel sides if its area is 64 m^2 .
9. The area of a trapezium is 40 m^2 . It has a height of 5 m and one of its parallel sides is 6 m. Find the length of the other parallel side.
10. In the diagram, CDE is an isosceles triangle with an area of 24 cm^2 .
If $AB = 8 \text{ cm}$ and $AD = 12 \text{ cm}$, calculate the area of the trapezium ABED.

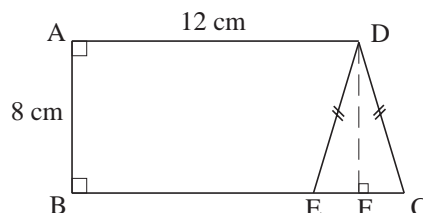

11. Find the value of the unknown in each of the following figures.

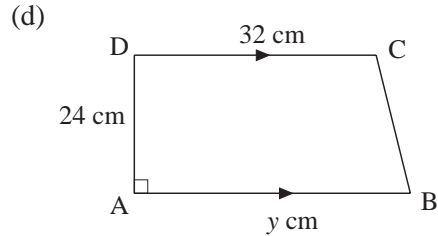
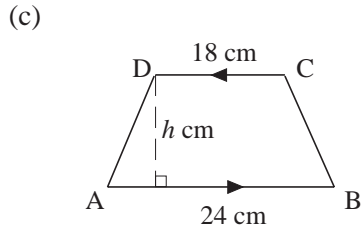
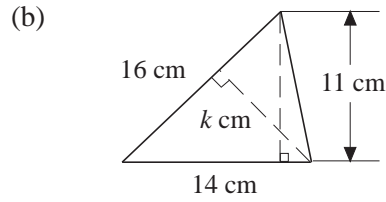
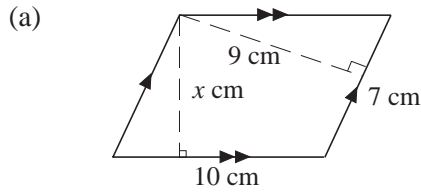

Area of ABCD = 273 cm^2

Area of ABCD = 912 cm^2

7.13 Surface Area

1. Find the surface area of each of the following cuboids with dimensions:

(a) $l = 10 \text{ cm}, b = 5 \text{ cm}, h = 4 \text{ cm},$

(b) $l = 8 \text{ m}, b = 2.5 \text{ cm}, h = 10 \text{ m}.$

2. Find the surface area of each cube of edge:

(a) 2 cm,

(b) 9.2 m.

3. The surface area of a cube is 24 cm^2 .

(a) What is the area of each face?

(b) Find the length of each edge.

4. Find the surface area of each of the following prisms:

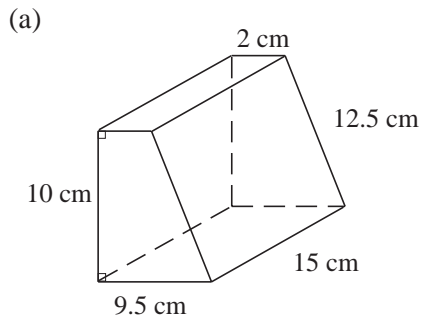

Trapezoidal prism

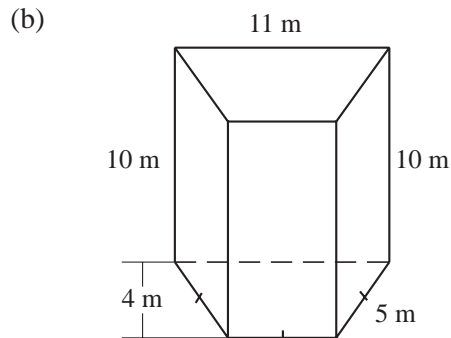

Trapezoidal prism

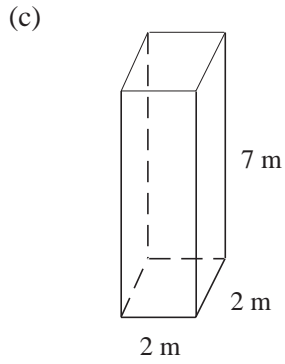

Square prism

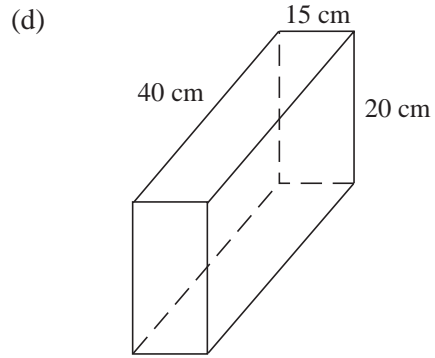

Rectangular prism

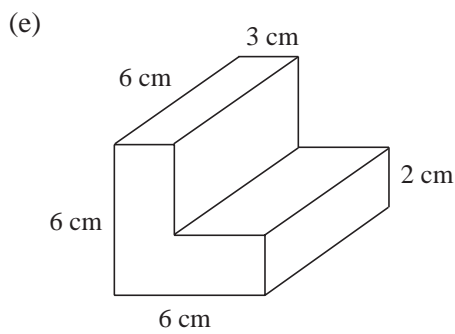

L-shaped prism

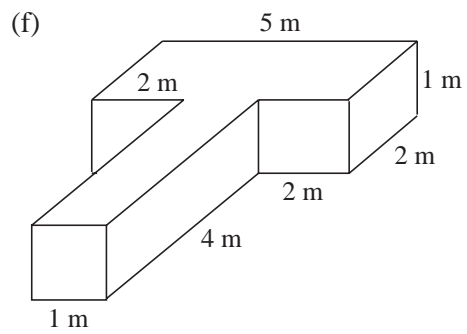

T-shaped prism

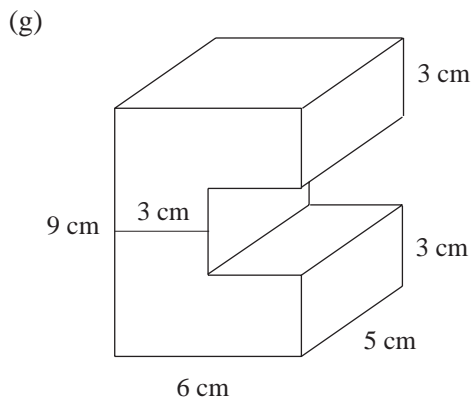

C-shaped prism

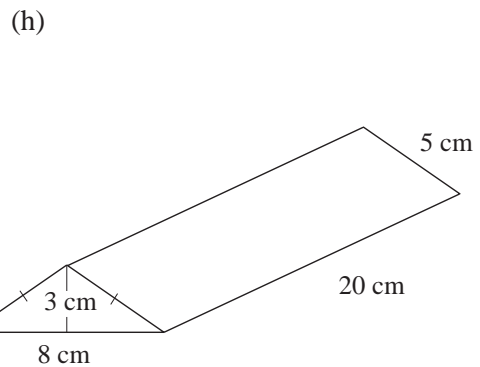

Triangular prism

5. Find the surface area of the following cylinders:

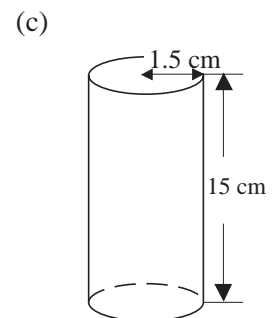
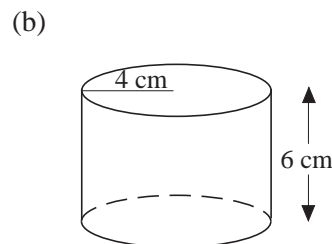
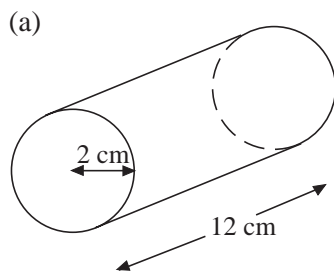

6. A cylindrical vase has a base whose external diameter is 8 cm and height is 12 cm. Find its external surface area.
7. If the area of the curved surface of a cylinder is 44 m^2 and its height is 2 m, find the radius of its circular ends.
8. Ali wants to wrap a hollow tube of length 21 cm with paper. He needs an extra 400 cm^2 of paper to fold over the edges. If the radius of the ends of the tube is 5 cm, how much paper does Ali need altogether?

7.14 Mass, Volume and Density

1. A rectangular block, 15 cm by 10 cm by 5 cm, has a mass of 1500 g. Find:
 - (a) its volume,
 - (b) its density.
2. Find the density of each of the following solids, given its mass and volume. Give your answers in g/cm^3 correct to 3 significant figures.
 - (a) mass = 45 g, volume = 8 cm^3 ;
 - (b) mass = 1.35 kg, volume = 250 cm^3 ;
 - (c) mass = 0.46 kg, volume = $78\,000 \text{ mm}^3$;
 - (d) mass = 0.325 kg, volume = 85 cm^3 ;
 - (e) mass = 567 g, volume = $0.000\,4 \text{ m}^3$;
 - (f) mass = 521.3 kg, volume = 0.12 m^3 .
3. Find the volume of each of the following solids, given its mass and density. Give your answers in cm^3 correct to 3 significant figures.
 - (a) mass = 78 g, density = 5.4 g/cm^3 ;
 - (b) mass = 179.2 kg, density = 0.82 g/cm^3 ;
 - (c) mass = 1.35 kg, density = 2.78 g/cm^3 ;
 - (d) mass = 45.3 kg, density = 5600 kg/m^3 ;
 - (e) mass = 867.5 kg, density = $12\,500 \text{ kg/m}^3$;
 - (f) mass = 790 g, density = 850 kg/m^3 .
4. Find the mass of each of the following solids, given its volume and density.
 - (a) volume = 98 cm^3 , density = 2.65 g/cm^3 ;
 - (b) volume = 459 cm^3 , density = 1.2 g/cm^3 ;
 - (c) volume = $0.005\,6 \text{ m}^3$, density = 0.75 g/cm^3 ;
 - (d) volume = 74 cm^3 , density = 3400 kg/m^3 ;
 - (e) volume = 432 cm^3 , density = 2450 kg/m^3 ;
 - (f) volume = 485 cm^3 , density = 650 kg/m^3 .

5. Calculate the densities of the following:
- A piece of metal that has a mass of 1400 g and a volume of 200 cm^3 ,
 - A substance that has a mass of 220 kg and a volume of 0.44 m^3 .
6. What is the mass of 400 cm^3 of a metal rod whose density is 2.4 g/cm^3 ?
7. Find the volume of a substance with a mass of 52.8 g and a density of 1.2 g/cm^3 .
8. A wooden cube is of side 5 cm. The density of the wood is 0.8 g/cm^3 . Calculate:
- the volume of the cube,
 - the mass of the cube.
9. what is the mass of a plank whose volume is 0.05 m^3 and density 900 kg/m^3 .
10. A ball bearing has mass 0.44 pounds.
 $1 \text{ kg} = 2.2 \text{ pounds}$
- Calculate the mass of the ball bearing in kilograms.
$$\text{Density} = \frac{\text{mass}}{\text{volume}}$$
 - When the mass of the ball bearing is measured in kg and the volume is measured in cm^3 , what are the units of the density?
 - The volume of a container is given by the formula:

$$V = 4L(3 - L)^2.$$
 Using **Mass = Volume \times Density** calculate the mass of the container when $L = 1.40 \text{ cm}$, and 1 cm^3 of the material has a mass of 0.160 kg.

(SEG)
11. The volume of a cuboid of length 20 cm and breadth 5 cm is 900 cm^3 . Calculate its height.
12. The volume of a cube is 125 cm^3 . What is the length of its edge?
13. The floor of an empty rectangular room measures 6 m by 4 m. Its height is 310 cm. What is the volume of air it contains in cubic metres?
14. The dimensions of a box are 6 cm by 5 cm by 10 cm. How many such boxes can be placed in a rectangular case whose dimensions are 30 cm by 15 cm by 20 cm?
15. The volume of a rectangular block is 720 cm^3 . If the area of its cross-section is 90 cm^2 , what is its height?
16. The base of a rectangular tin has an area of 150 cm^2 . If the tin contains 450 cm^3 of water, what is the height of water in the tin?

7.15 Volumes, Areas and Lengths

1. Calculate the volume of each of the following prisms:

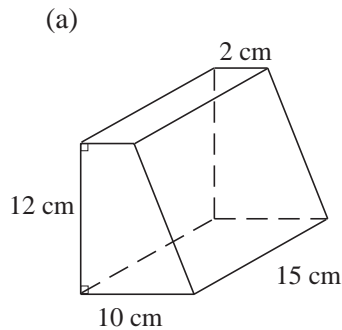

Trapezoidal prism

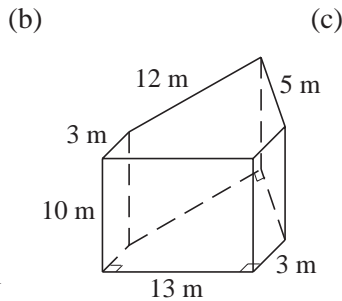

Pentagonal prism

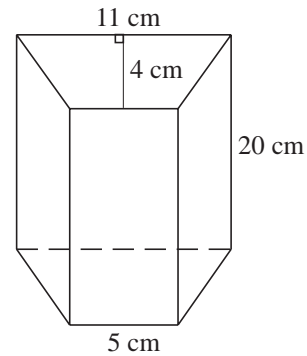

Trapezoidal prism

2. What are the areas of the shaded regions in the following figures:

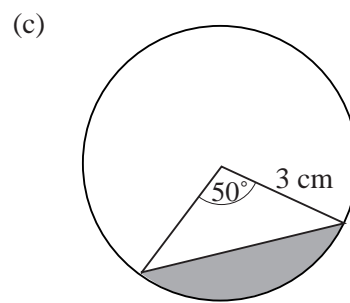
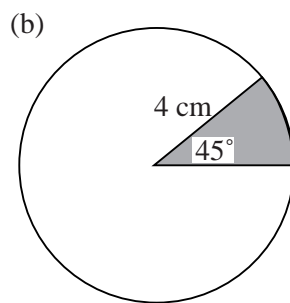
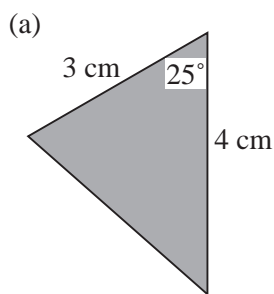

3. What is the volume of a sphere with:

- (a) radius 4 cm, (b) radius 21 cm,
(c) diameter 6.42 cm, (d) diameter 2.5 cm?

4. What is the radius of a sphere whose volume is:

- (a) $1437\frac{1}{3} \text{ cm}^3$, (b) $288\pi \text{ cm}^3$?

5. A spherical container is 20 cm in diameter. Calculate the volume of water if the container is :

- (a) half-filled with water, (b) filled completely with water.

6. A spherical lead ball 15 cm in radius is melted and made into smaller spherical balls of radius 3 cm each. How many smaller balls can be obtained?

7. The side of the base of a square pyramid is 7 m long. Its height is 4.5 m. Find the volume of the pyramid.

8. A square pyramid has a volume of 270 m^3 and a height of 10 m. Calculate:

- (a) the area of its base, (b) the length of the side of its base.

9. The length and breadth of the base of a rectangular pyramid are 8.4 m and 7.5 m respectively. Its height is 10 m. Find the volume of the pyramid.
10. The volume of a rectangular pyramid is 72.5 m^3 . The area of its base is 25 m^2 . Find its height.
11. Find the surface area of a sphere with:
- (a) radius 2.8 cm, (b) radius 13 m,
(c) diameter 6.3 m, (d) diameter 11.2 m.
- Give each answer correct to the nearest whole unit.
12. Find the radius of a sphere whose surface area is
- (a) 154 cm^2 , (b) 2464 cm^2 .
13. Find the surface area of each of the following candles which is in the shape of a hemisphere with:
- (a) radius 10 cm, (b) diameter 5 m.
14. A cone has a height of 10 cm and a base radius of 6.5 cm. Calculate:
- (a) the area of its base, (b) the volume of the cone.
- Give each answer correct to 3 significant figures.
15. A cone has a height of 14 cm and a base radius of 4.2 cm. Calculate its volume. Give your answer correct to 1 decimal place.
16. Find the slant height of a cone whose base radius is 1.4 m and whose area of curved surface is 132 m^2 .
17. In a conical tent, the diameter of the base is 7 m and the slant height is 4.5 m. Calculate, correct to the nearest m^2 , the amount of material used for making this tent including the base.
18. A party hat is in the shape of a cone with a slant height of 20 cm. If the circumference of the base is 88 cm, calculate:
- (a) the radius of the base,
(b) the amount of paper used for making it. Give your answer in cm^2 .
19. An arc of a circle with radius 4.5 cm subtends an angle of 84° at the centre of the circle. Find the length of the arc. Give your answer correct to 1 decimal place.
20. A sector of a circle with radius 5 cm has an angle of 104° at the centre of the circle. Find the area of the sector. Give your answer correct to the nearest whole number.

21. The pendulum of a clock is 50 cm long. The pendulum bob swings from P to Q through an angle of 12° .

What is the area of the sector covered by the pendulum as the bob swings from P to Q?

Give your answer correct to 1 decimal place.

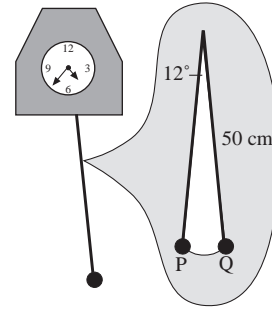

22. The hour hand of a clock sweeps through a sector with an area of 130 cm^2 in 5 hours. What is the length of the hour hand?

Give your answer correct to the nearest whole number.

23. Vijay is planning his garden. The shaded area in the diagram represents a path.

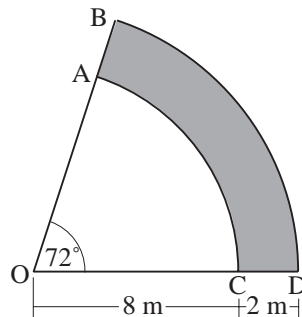

Not to scale

AC and BD are arcs of circles whose centres are at O.

$OC = 8 \text{ m}$ $CD = 2 \text{ m}$ Angle $BOD = 72^\circ$

Take π to be 3.14 or use the π key on your calculator.

- (a) Calculate the area of the sector OAC.
- (b) Calculate the area of the path.
- (c) Vijay uses 1.2 m^3 of concrete to make the path. The depth of the concrete is the same over the whole path.

Calculate, in centimetres, the depth of the concrete.

(SEG)

24. A cylindrical birthday cake is cut into pieces. One of the pieces is shown. O is the centre of the circle.

$OD = 9 \text{ cm}$

$OA = OB = 10 \text{ cm}$

Arc length $AB = 3 \text{ cm}$

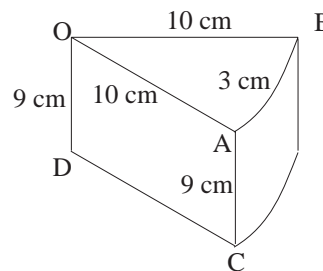

Not to scale

- (a) Calculate the size of angle AOB.
Take π to be 3.14 or use the π key on your calculator.
- (b) Calculate the area of the sector AOB.
- (c) Calculate the total surface area of one of the pieces of cake.

(SEG)

25. A "TRAFFIC CONE" is made from a cone and a cuboid.
 The cone has a radius $OA = 20$ cm and slant height $AB = 81$ cm.
 The cuboid has a square base, centre O, of side 40 cm and height 15 cm.

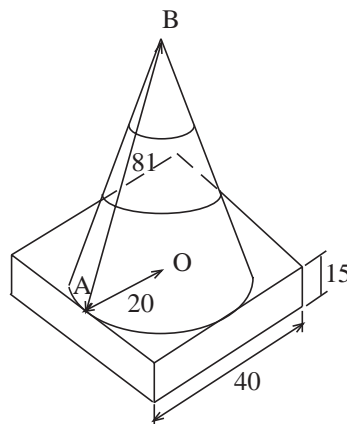

Not to scale

- How many planes of symmetry has the "TRAFFIC CONE"?
- Calculate the vertical height OB of the cone.
- Calculate the volume of the cone.
 Take π to be 3.14 or use the π key on your calculator.
- Calculate the volume of the "TRAFFIC CONE".

(SEG)

26. A circular badge is shown. It consists of a circle centre O and radius 3 cm.
 The design on the badge is an arc BOC of a circle centre A and radius also 3 cm.
 The lines $OA = OB = OC = AB = AC = 3$ cm.

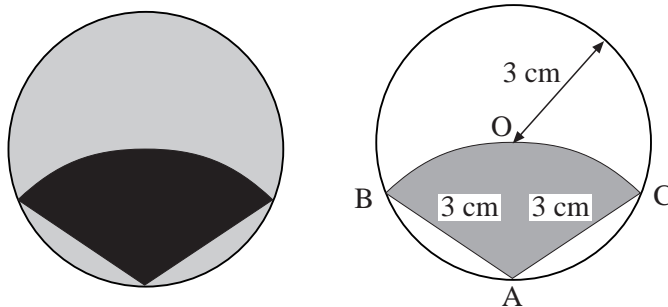

Not to scale

- Find the size of angle BAC.
- Find the area of the shaded sector OBAC.
 Take π to be 3.14 or use the π key on your calculator.
- The shaded sector OBAC is to be painted red.
 The rest of the badge is to be painted yellow.
 Find the area that is to be painted yellow.

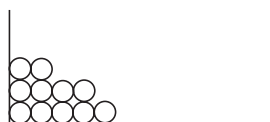

Not to scale

- (d) The circles for the badges are cut out from square sheets of metal 50 cm by 50 cm as shown. What is the maximum number of badges that can be cut from the square?

(SEG)

27. The head of a baby's rattle is a sphere.

The sphere has a diameter of 8 cm.

Calculate the volume of the sphere.

Take π to be 3.14 or use the π key on your calculator.

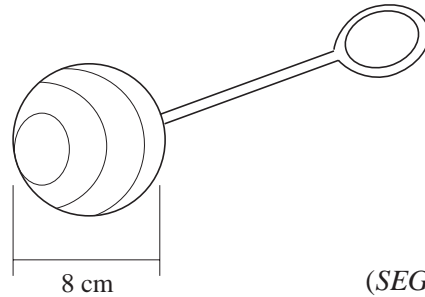

(SEG)

28. A bar of gold is a prism with volume 165 cm^3 .

Its cross-section is a trapezium with dimensions as shown.

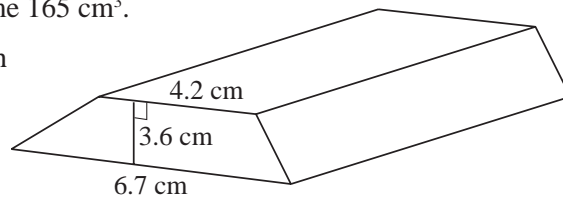

- (a) Calculate the length of the gold bar.
- (b) A similar bar of gold has a volume of 675.84 cm^3 . Calculate the height of this bar of gold.
- (c) A different bar of gold has a volume given by the formula $V = h^2 y$. Rearrange the formula to make h the subject.

(OCR)

29. A marble paperweight consists of a cuboid and a hemisphere as shown in the diagram.

The hemisphere has a radius of 4 cm.

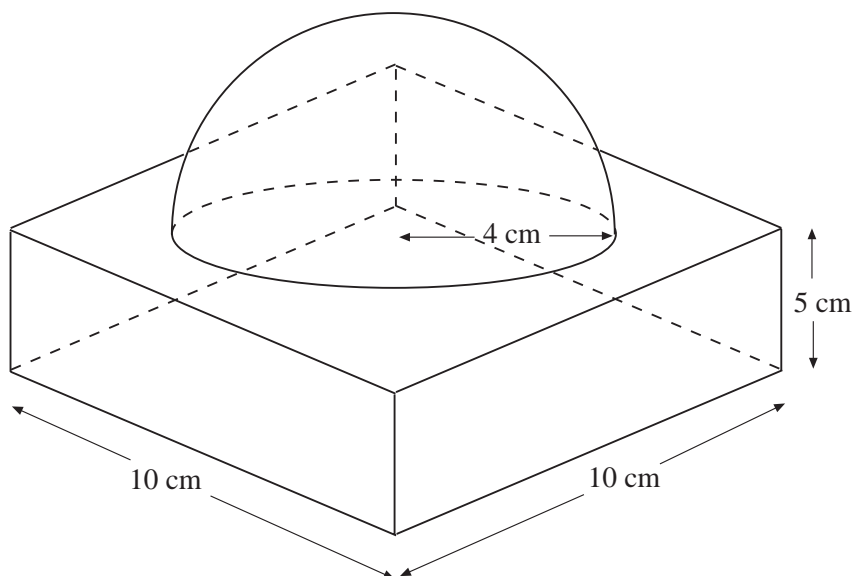

Calculate the volume of the paperweight.

(AQA)

7.16 Dimensions

1. If a , b , c and d are all lengths, consider each expression and decide if it could be a length, area, volume or none of these:

(a) $ab + cd$	(b) abc	(c) $a + b + c + d$
(d) $a^2 + b^2 + c^2$	(e) \sqrt{abcd}	(f) $abc + bcd + cda + dab$
(g) $\frac{a}{b} + \frac{c}{d}$	(h) $a + bcd$	(i) $\sqrt{(ab)^2 + (cd)^2}$

- 2.

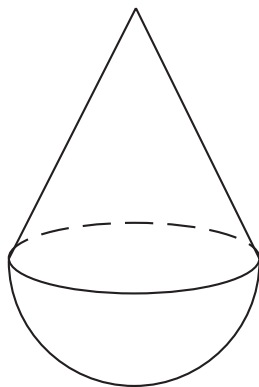

Which of the following formulae could be the volume of the solid shape illustrated opposite.

(i) $V = \pi \frac{ah}{12} + \frac{2}{3} \pi a^2$
(ii) $V = \pi \frac{a^2h}{12} + \frac{2}{3} \pi a^3$
(iii) $V = \pi \frac{ah^2}{12} + \frac{2}{3} \pi a^2$
(iv) $V = \pi \frac{(ah)^2}{12} + \frac{4}{3} \pi a^3$

3. By considering dimensions, decide whether the following expressions could be a formula for **perimeter**, **area** or **volume**.

In the expressions below, a , b and c are all lengths.

(a) $a + b + c$	(b) $\frac{2}{3} \pi a^3 + \pi a^2 b$	(SEG)
-----------------	---------------------------------------	-------

4. Explain whether the following formulae could be a volume or not. In each formula, a , b , c and d are lengths.

(a) $\frac{4}{3} \pi a^2$	(b) πabc	(c) $(\pi ab)^2$	(d) $4\pi \left(\frac{ab}{c}\right)^3$
(e) $\frac{(a + b + c)^3}{12}$	(f) $\pi(ab + cd)^2$	(g) $(ab + bc + cd)^{\frac{3}{2}}$	

5. The table shows some expressions.

a , b , c and d represent lengths.

π and 3 are numbers which have no dimensions.

$3a^2$	$\frac{\pi ab^3}{3d}$	πbc	$ac + bd$	$\pi(a + b)$	$3(c + d)^3$	$3\pi bc^2$
--------	-----------------------	----------	-----------	--------------	--------------	-------------

Write down the **three** expressions which could represent areas.

(Edexcel)