

7 Mensuration

7.11 Discrete and Continuous Measures

1. State whether each of the following is discrete or continuous:
 - (a) number of goals scored in a football match,
 - (b) the length of a human foot,
 - (c) the number of teachers in your school,
 - (d) the time it takes to travel to London,
 - (e) the number of players in a tennis tournament,
 - (f) the weight of your school bag,
 - (g) the number of rabbits in the country.
2. In each case state whether the value given is exact or give the range of values in which it could lie.
 - (a) Shoe size is $6\frac{1}{2}$.
 - (b) The radius of the earth is 3866 km.
 - (c) The cost of a shirt is £5.99.
 - (d) A newspaper has 64 pages.
 - (e) The capacity of a bus is 73 people.
 - (f) The weight of the contents of a tin of baked beans is 220 grams.
 - (g) 486 people voted for the Monster Raving Loony party.
 - (h) The volume of a drink is 0.175 litres.

7.12 Areas of Parallelograms, Trapeziums, Kites and Rhombuses

1. Find the area of each of the following shapes:

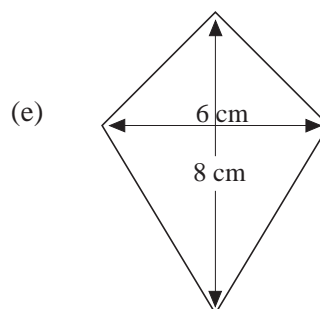
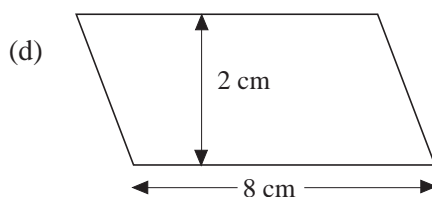
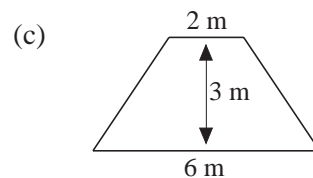
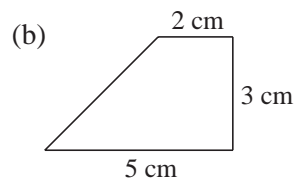
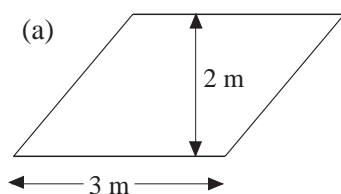

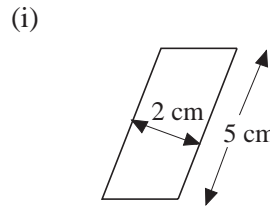
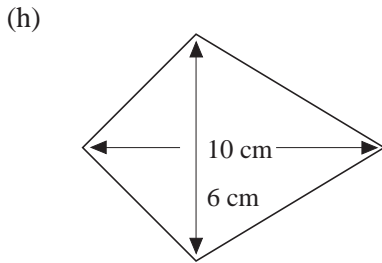
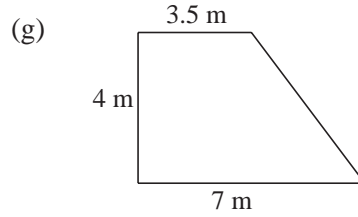
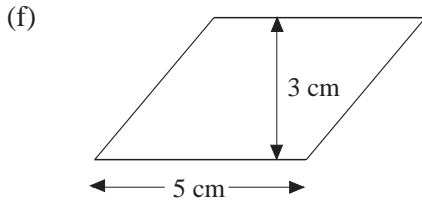

2. Find the areas of the following parallelograms:

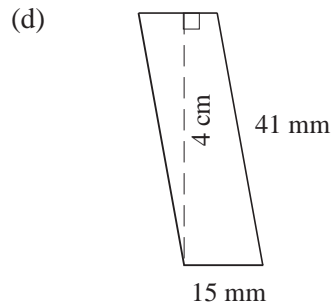
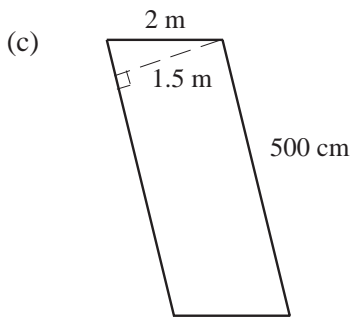
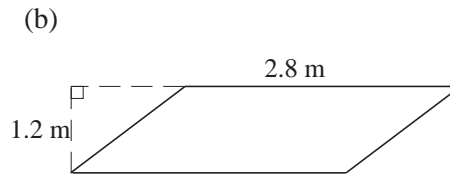
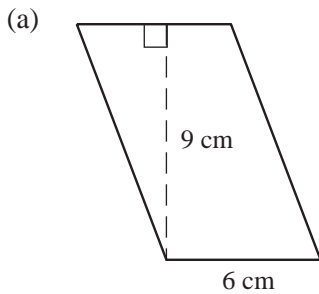

(Give your answer in m^2)

(Give your answer in mm^2)

3. Find the base of a parallelogram, given that its height is 8 cm and its area 64 cm^2 .

4. The area of a parallelogram is 108 mm^2 . Find its height if the base is 12 mm.

5. Find the area of the trapezium.
Give your answer in cm^2 .

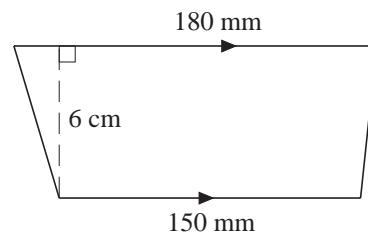

6. Find the area of the trapezium.
Give your answer in mm^2 .

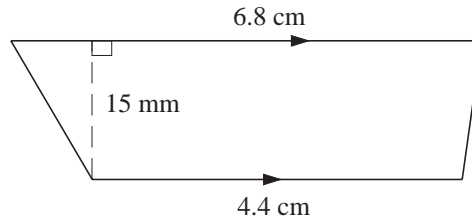

7. A trapezium has an area of 120 cm^2 . Its parallel sides measure 14 cm and 10 cm. Find its height.
8. A trapezium has a height of 8 m. What is the sum of its parallel sides if its area is 64 m^2 .
9. The area of a trapezium is 40 m^2 . It has a height of 5 m and one of its parallel sides is 6 m. Find the length of the other parallel side.
10. In the diagram, CDE is an isosceles triangle with an area of 24 cm^2 . If $AB = 8 \text{ cm}$ and $AD = 12 \text{ cm}$, calculate the area of the trapezium ABED.

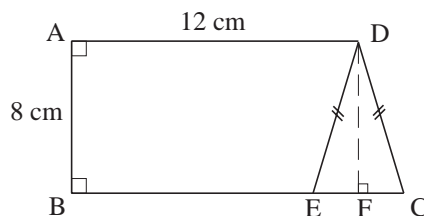

11. Find the value of the unknown in each of the following figures.

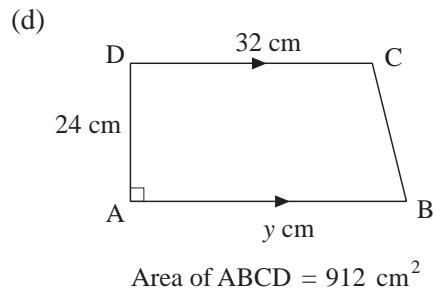
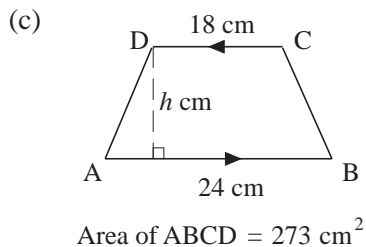
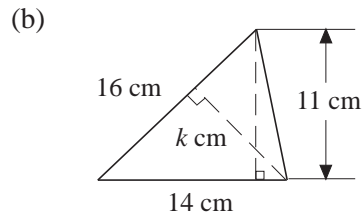
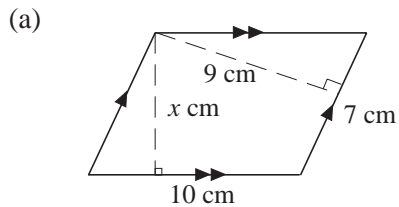

7.13 Surface Area

- Find the surface area of each of the following cuboids with dimensions:
 - $l = 10 \text{ cm}$, $b = 5 \text{ cm}$, $h = 4 \text{ cm}$,
 - $l = 8 \text{ m}$, $b = 2.5 \text{ cm}$, $h = 10 \text{ m}$.
- Find the surface area of each cube of edge:
 - 2 cm ,
 - 9.2 m .
- The surface area of a cube is 24 cm^2 .
 - What is the area of each face?
 - Find the length of each edge.
- Find the surface area of each of the following prisms:

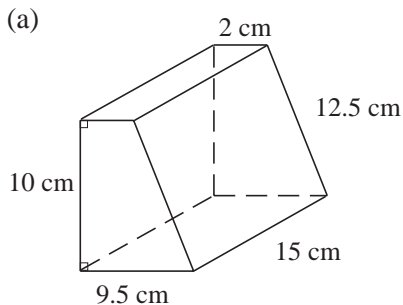

Trapezoidal prism

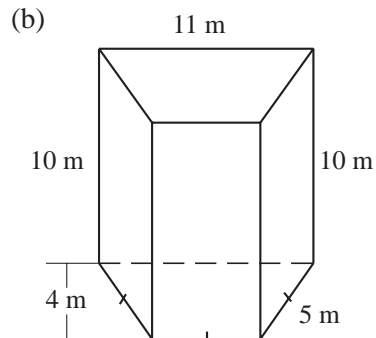

Trapezoidal prism

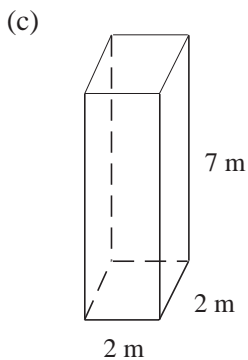

Square prism

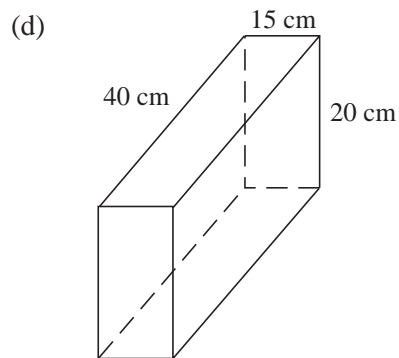

Rectangular prism

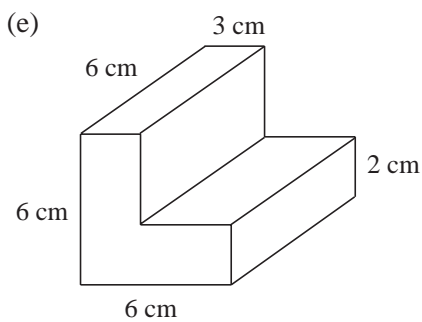

L-shaped prism

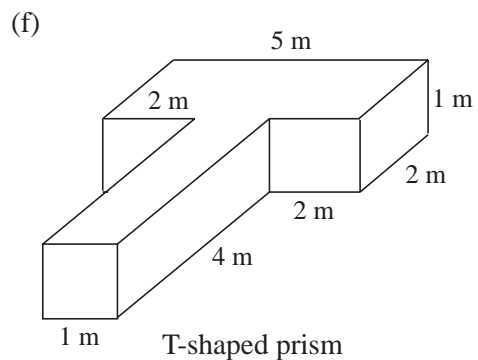

T-shaped prism

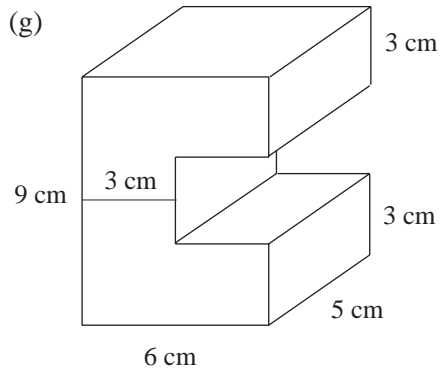

C-shaped prism

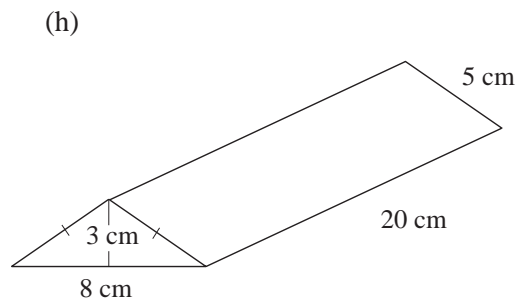

Triangular prism

5. Find the surface area of the following cylinders:

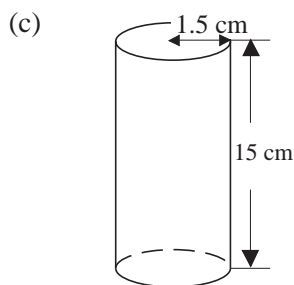
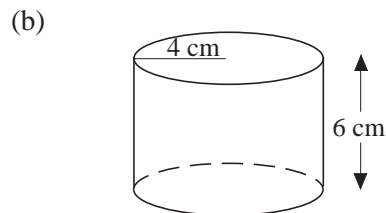
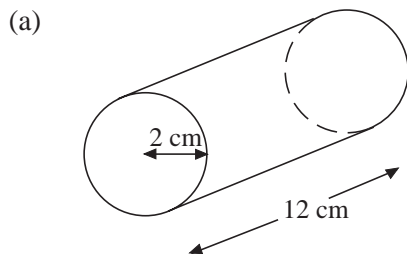

6. A cylindrical vase has a base whose external diameter is 8 cm and height is 12 cm. Find its external surface area.
7. If the area of the curved surface of a cylinder is 44 m^2 and its height is 2 m, find the radius of its circular ends.
8. Ali wants to wrap a hollow tube of length 21 cm with paper. He needs an extra 400 cm^2 of paper to fold over the edges. If the radius of the ends of the tube is 5 cm, how much paper does Ali need altogether?

7.14 Mass, Volume and Density

1. A rectangular block, 15 cm by 10 cm by 5 cm, has a mass of 1500 g. Find:
- its volume,
 - its density.

2. Find the density of each of the following solids, given its mass and volume. Give your answers in g/cm^3 correct to 3 significant figures.
- (a) mass = 45 g, volume = 8 cm^3 ;
 - (b) mass = 1.35 kg, volume = 250 cm^3 ;
 - (c) mass = 0.46 kg, volume = $78\,000 \text{ mm}^3$;
 - (d) mass = 0.325 kg, volume = 85 cm^3 ;
 - (e) mass = 567 g, volume = $0.000\,4 \text{ m}^3$;
 - (f) mass = 521.3 kg, volume = 0.12 m^3 .
3. Find the volume of each of the following solids, given its mass and density. Give your answers in cm^3 correct to 3 significant figures.
- (a) mass = 78 g, density = 5.4 g/cm^3 ;
 - (b) mass = 179.2 kg, density = 0.82 g/cm^3 ;
 - (c) mass = 1.35 kg, density = 2.78 g/cm^3 ;
 - (d) mass = 45.3 kg, density = 5600 kg/m^3 ;
 - (e) mass = 867.5 kg, density = $12\,500 \text{ kg/m}^3$;
 - (f) mass = 790 g, density = 850 kg/m^3 .
4. Find the mass of each of the following solids, given its volume and density.
- (a) volume = 98 cm^3 , density = 2.65 g/cm^3 ;
 - (b) volume = 459 cm^3 , density = 1.2 g/cm^3 ;
 - (c) volume = $0.005\,6 \text{ m}^3$, density = 0.75 g/cm^3 ;
 - (d) volume = 74 cm^3 , density = 3400 kg/m^3 ;
 - (e) volume = 432 cm^3 , density = 2450 kg/m^3 ;
 - (f) volume = 485 cm^3 , density = 650 kg/m^3 .
5. Calculate the densities of the following:
- (a) A piece of metal that has a mass of 1400 g and a volume of 200 cm^3 ,
 - (b) A substance that has a mass of 220 kg and a volume of 0.44 m^3 .
6. What is the mass of 400 cm^3 of a metal rod whose density is 2.4 g/cm^3 ?
7. Find the volume of a substance with a mass of 52.8 g and a density of 1.2 g/cm^3 .
8. A wooden cube is of side 5 cm. The density of the wood is 0.8 g/cm^3 . Find:
- (a) the volume of the cube,
 - (b) the mass of the cube.
9. Find the mass of a plank whose volume is 0.05 m^3 and density 900 kg/m^3 .

10. A ball bearing has mass 0.44 pounds.

$$1 \text{ kg} = 2.2 \text{ pounds}$$

- (a) (i) Calculate the mass of the ball bearing in kilograms.

$$\text{Density} = \frac{\text{mass}}{\text{volume}}$$

- (ii) When the mass of the ball bearing is measured in kg and the volume is measured in cm^3 , what are the units of the density?

- (b) The volume of a container is given by the formula:

$$V = 4L(3 - L)^2.$$

Using **Mass = Volume** \times **Density** calculate the mass of the container when $L = 1.40 \text{ cm}$, and 1 cm^3 of the material has a mass of 0.160 kg.

(SEG)

11. The volume of a cuboid of length 20 cm and breadth 5 cm is 900 cm^3 . Find its height.
12. The volume of a cube is 125 cm^3 . Find the length of its edge.
13. The floor of an empty rectangular room measures 6 m by 4 m. Its height is 310 cm. What is the volume of air it contains in cubic metres?
14. The dimensions of a box are 6 cm by 5 cm by 10 cm. How many such boxes can be placed in a rectangular case whose dimensions are 30 cm by 15 cm by 20 cm?
15. The volume of a rectangular block is 720 cm^3 . If the area of its cross-section is 90, what is its height?
16. The base of a rectangular tin has an area of 150 cm^2 . If the tin contains 450 cm^3 of water, what is the height of water in the tin?

7.15 Volumes, Areas and Lengths

1. Calculate the volume of each of the following prisms:

(a)

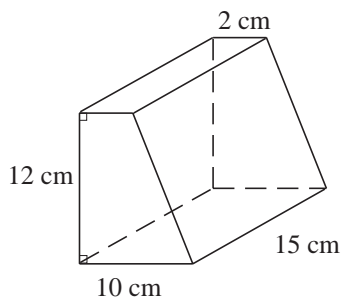

Trapezoidal prism

(b)

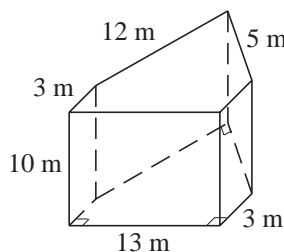

Pentagonal prism

(c)

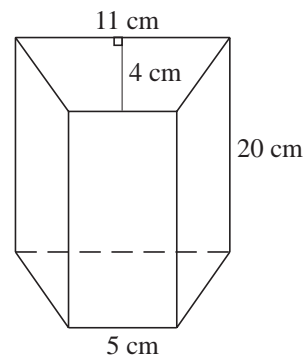

Trapezoidal prism

2. Find the area of the shaded regions in the following figures:

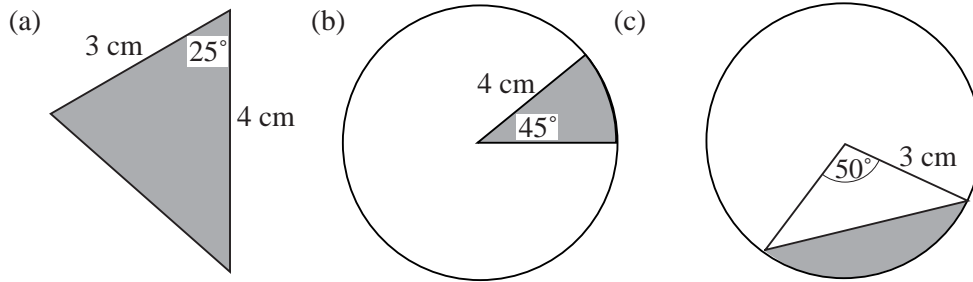

3. Find the volume of a sphere with:

- (a) radius 4 cm, (b) radius 21 cm,
(c) diameter 6.42 cm, (d) diameter 2.5 cm.

4. Find the radius of a sphere whose volume is:

- (a) $1437\frac{1}{3} \text{ cm}^3$, (b) $288\pi \text{ cm}^3$.

5. A spherical container is 20 cm in diameter. Calculate the volume of water if the container is :

- (a) half-filled with water, (b) filled completely with water.

6. A spherical lead ball 15 cm in radius is melted and made into smaller spherical balls of radius 3 cm each. How many smaller balls can be obtained?

7. The side of the base of a square pyramid is 7 m long. Its height is 4.5 m. Find the volume of the pyramid.

8. A square pyramid has a volume of 270 m^3 and a height of 10 m. Calculate:

- (a) the area of its base, (b) the length of the side of its base.

9. The length and breadth of the base of a rectangular pyramid are 8.4 m and 7.5 m respectively. Its height is 10 m. Find the volume of the pyramid.

10. The volume of a rectangular pyramid is 72.5 m^3 . The area of its base is 25 m^2 . Find its height.

11. Find the surface area of a sphere with:

- (a) radius 2.8 cm, (b) radius 13 m,
(c) diameter 6.3 m, (d) diameter 11.2 m.

Give each answer correct to the nearest whole unit.

12. Find the radius of a sphere whose surface area is

- (a) 154 cm^2 , (b) 2464 cm^2 .

13. Find the surface area of each of the following candles which is in the shape of a hemisphere with:
- (a) radius 10 cm, (b) diameter 5 m.
14. A cone has a height of 10 cm and a base radius of 6.5 cm. Calculate:
- (a) the area of its base, (b) the volume of the cone.
- Give each answer correct to 3 significant figures.
15. A cone has a height of 14 cm and a base radius of 4.2 cm. Calculate its volume. Give your answer correct to 1 decimal place.
16. Find the slant height of a cone whose base radius is 1.4 m and whose area of curved surface is 132 m^2 .
17. In a conical tent, the diameter of the base is 7 m and the slant height is 4.5 m. Calculate, correct to the nearest m^2 , the amount of material used for making this tent including the base.
18. A party hat is in the shape of a cone with a slant height of 20 cm. If the circumference of the base is 88 cm, calculate:
- (a) the radius of the base,
- (b) the amount of paper used for making it. Give your answer in cm^2 .
19. An arc of a circle with radius 4.5 cm subtends an angle of 84° at the centre of the circle. Find the length of the arc. Give your answer correct to 1 decimal place.
20. A sector of a circle with radius 5 cm has an angle of 104° at the centre of the circle. Find the area of the sector. Give your answer correct to the nearest whole number.
21. The pendulum of a clock is 50 cm long. The pendulum bob swings from P to Q through an angle of 12° .

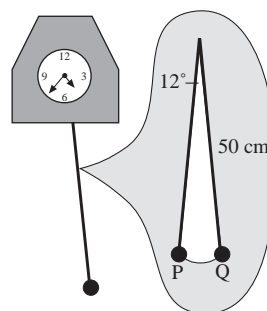

What is the area of the sector covered by the pendulum as the bob swings from P to Q?
Give your answer correct to 1 decimal place.

22. The hour hand of a clock sweeps through a sector with an area of 130 cm^2 in 5 hours. Find the length of the hour hand. Give your answer correct to the nearest whole number.

23. Vijay is planning his garden. The shaded area in the diagram represents a path.

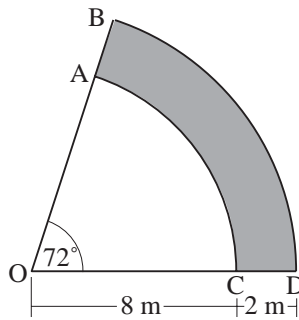

Not to scale

AC and BD are arcs of circles whose centres are at O.

$$OC = 8 \text{ m} \quad CD = 2 \text{ m} \quad \text{Angle } BOD = 72^\circ$$

Take π to be 3.14 or use the π key on your calculator.

- Calculate the area of the sector OAC.
- Calculate the area of the path.
- Vijay uses 1.2 m^3 of concrete to make the path. The depth of the concrete is the same over the whole path. Calculate, in centimetres, the depth of the concrete.

(SEG)

24. A cylindrical birthday cake is cut into pieces. One of the pieces is shown. O is the centre of the circle.

$$OD = 9 \text{ cm} \quad OA = OB = 10 \text{ cm} \quad \text{Arc length } AB = 3 \text{ cm}$$

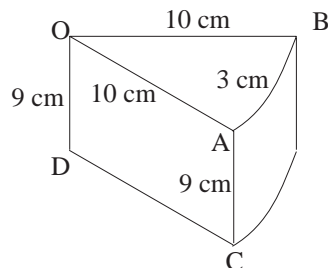

Not to scale

- Calculate the size of angle AOB.
Take π to be 3.14 or use the π key on your calculator.
- Calculate the area of the sector AOB.
- Calculate the total surface area of one of the pieces of cake.

(SEG)

25. A "TRAFFIC CONE" is made from a cone and a cuboid.
 The cone has a radius $OA = 20$ cm and slant height $AB = 81$ cm.
 The cuboid has a square base, centre O , of side 40 cm and height 15 cm.

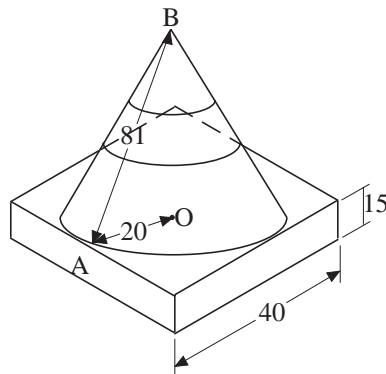

Not to scale

- How many planes of symmetry has the "TRAFFIC CONE"?
- Calculate the vertical height OB of the cone.
- Calculate the volume of the cone.
 Take π to be 3.14 or use the π key on your calculator.
- Calculate the volume of the "TRAFFIC CONE".

(SEG)

26. A circular badge is shown. It consists of a circle centre O and radius 3 cm. The design on the badge is an arc BOC of a circle centre A and radius also 3 cm. The lines $OA = OB = OC = AB = AC = 3$ cm.

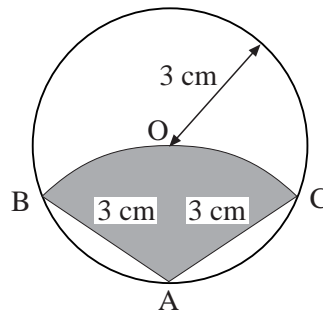
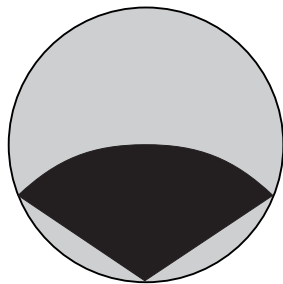

Not to scale

- Find the size of angle BAC .
- Find the area of the shaded sector $OBAC$.
 Take π to be 3.14 or use the π key on your calculator.
- The shaded sector $OBAC$ is to be painted red.
 The rest of the badge is to be painted yellow.
 Find the area that is to be painted yellow.

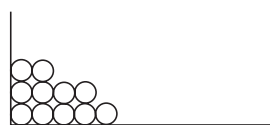

Not to scale

- (d) The circles for the badges are cut out from square sheets of metal 50 cm by 50 cm as shown. What is the maximum number of badges that can be cut from the square?

(SEG)

27. The head of a baby's rattle is a sphere.

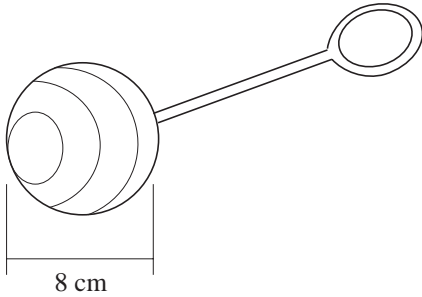

The sphere has a diameter of 8 cm. Calculate the volume of the sphere. Take π to be 3.14 or use the π key on your calculator.

(SEG)

28. A bar of gold is a prism with volume 165 cm^3 . Its cross-section is a trapezium with dimensions as shown.

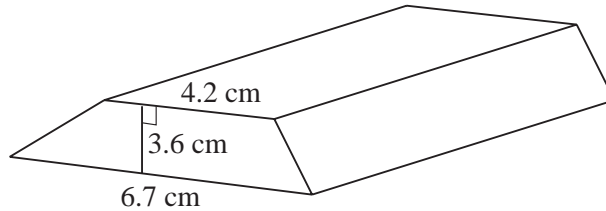

- (a) Calculate the length of the gold bar.
 (b) A similar bar of gold has a volume of 675.84 cm^3 . Calculate the height of this bar of gold.
 (c) A different bar of gold has a volume given by the formula $V = h^2 y$. Rearrange the formula to make h the subject.

(OCR)

29. A marble paperweight consists of a cuboid and a hemisphere as shown in the diagram. The hemisphere has a radius of 4 cm.

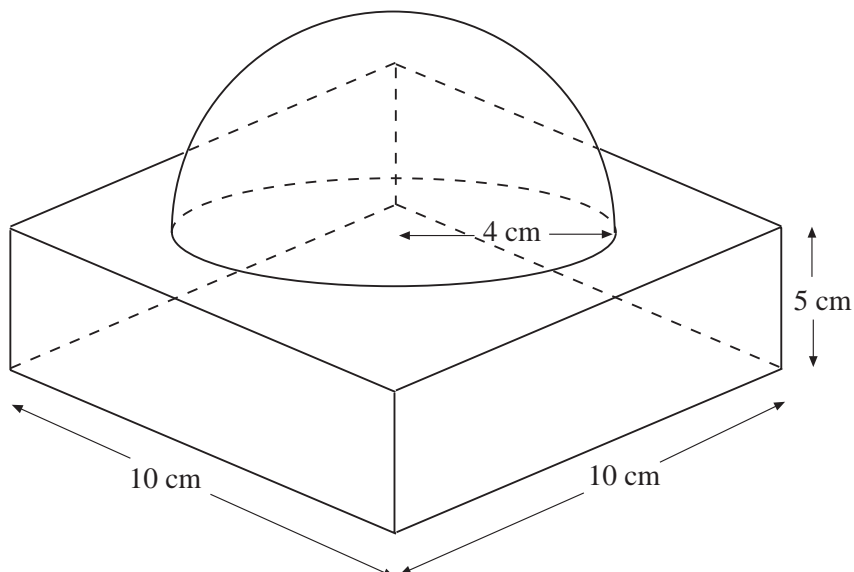

Calculate the volume of the paperweight.

(AQA)

7.16 Dimensions

1. If a , b , c and d are all lengths, consider each expression and decide if it could be a length, area, volume or none of these:

(a) $ab + cd$	(b) abc	(c) $a + b + c + d$
(d) $a^2 + b^2 + c^2$	(e) \sqrt{abcd}	(f) $abc + bcd + cda + dab$
(g) $\frac{a}{b} + \frac{c}{d}$	(h) $a + bcd$	(i) $\sqrt{(ab)^2 + (cd)^2}$

- 2.

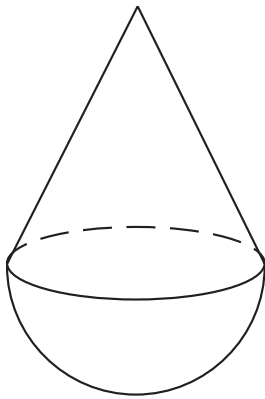

Which of the following formulae could be the volume of the solid shape illustrated opposite.

(i) $V = \pi \frac{ah}{12} + \frac{2}{3} \pi a^2$
(ii) $V = \pi \frac{a^2h}{12} + \frac{2}{3} \pi a^3$
(iii) $V = \pi \frac{ah^2}{12} + \frac{2}{3} \pi a^2$
(iv) $V = \pi \frac{(ah)^2}{12} + \frac{4}{3} \pi a^3$

3. By considering dimensions, decide whether the following expressions could be a formula for

perimeter, area or volume.

In the expressions below, a , b and c are all lengths.

(a) $a + b + c$	(b) $\frac{2}{3} \pi a^3 + \pi a^2 b$
-----------------	---------------------------------------

(SEG)

4. Explain whether the following formulae could be a volume or not. In each a , b , c and d are lengths.

(a) $\frac{4}{3} \pi a^2$	(b) πabc	(c) $(\pi ab)^2$	(d) $4\pi \left(\frac{ab}{c}\right)^3$
(e) $\frac{(a + b + c)^3}{12}$	(f) $\pi(ab + cd)^2$	(g) $(ab + bc + cd)^{\frac{3}{2}}$	

5. The table shows some expressions.

a , b , c and d represent lengths.

π and 3 are numbers which have no dimensions.

$3a^2$	$\frac{\pi ab^3}{3d}$	πbc	$ac + bd$	$\pi(a + b)$	$3(c + d)^3$	$3\pi bc^2$
--------	-----------------------	----------	-----------	--------------	--------------	-------------

Write down the **three** expressions which could represent areas.

(Edexcel)

7.17 Areas of Triangles

1. Calculate the areas of the following triangles:

(a)

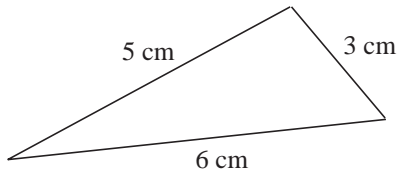

(b)

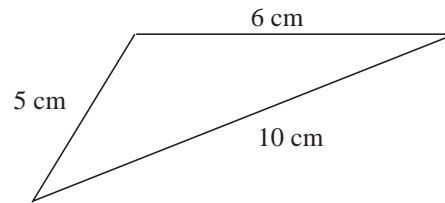

(c)

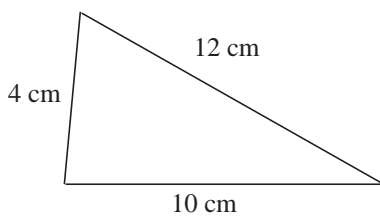

(d)

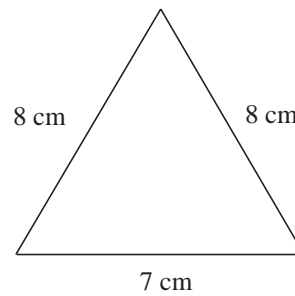

2. For each of the triangles shown, find:

- (i) the area of the triangle,
- (ii) the angle shown by θ .

(a)

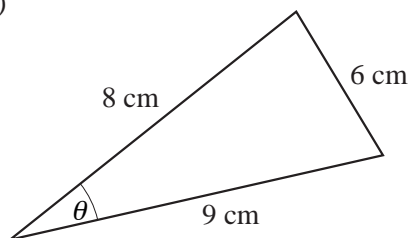

(b)

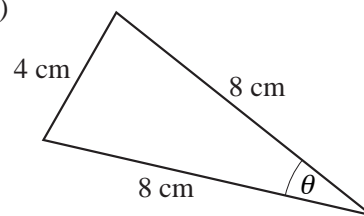

(c)

