

4 Trigonometry

4.1 Squares and Triangles

1. For each of the triangles below state whether they are scalene, isosceles or equilateral.

(a)

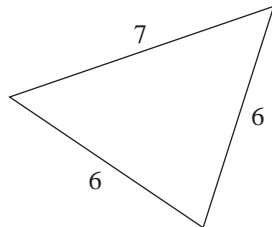

(b)

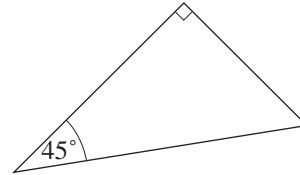

(c)

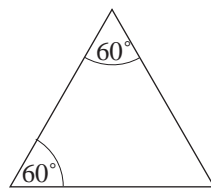

(d)

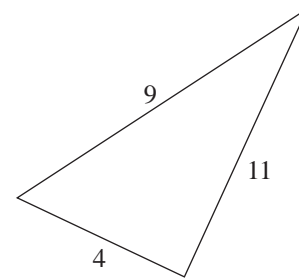

2. Find the area of a square of side

(a) 3 cm

(b) 2 m

(c) 10 mm

3. Find the length of the sides of a square that has area

(a) 49 cm²

(b) 36 m²

(c) 10000 mm²

4. How many squares of 1 cm² can be cut from a square of side 10 cm?

4.2 Pythagoras' Theorem

1. For each of the following, find the length of the hypotenuse, giving your answer correct to 1 decimal place.

(a)

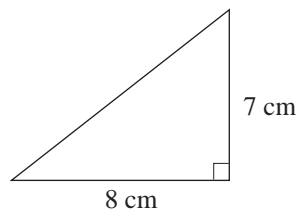

(b)

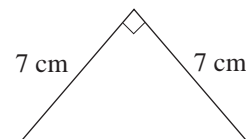

(c)

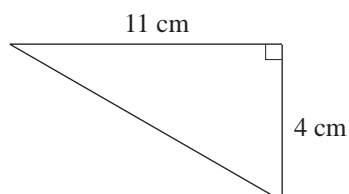

(d)

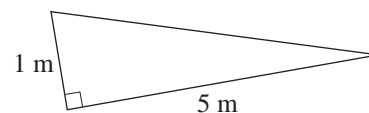

2. Find the length of the side marked r in each triangle.

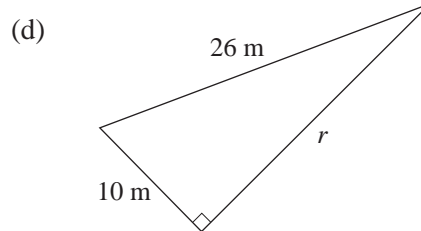
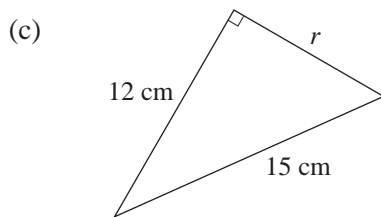
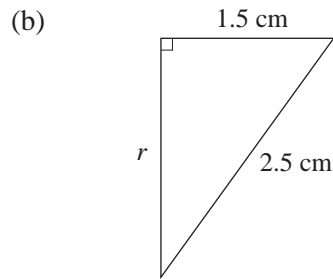
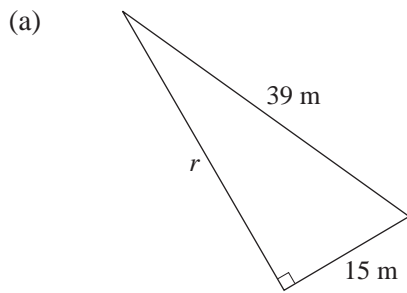

3. For each of the following triangles, find the length of the side marked s . Give your answer correct to 1 decimal place.

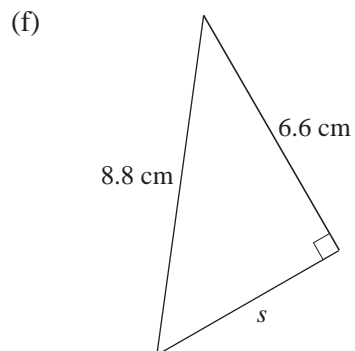
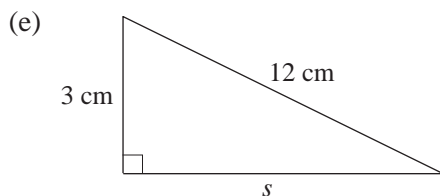
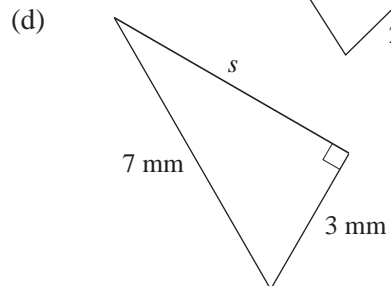
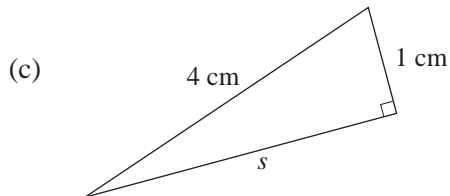
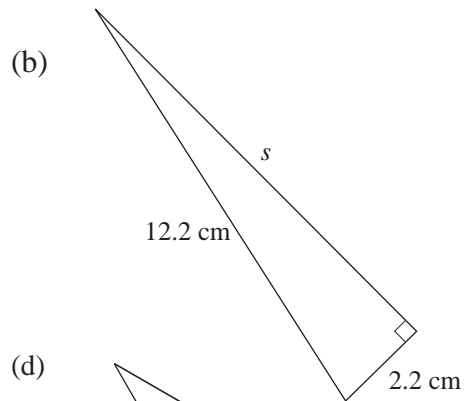
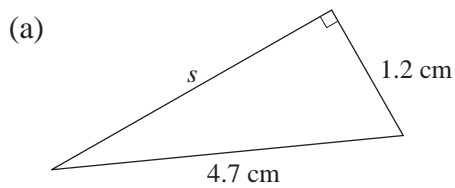

4. Find the height of an equilateral triangle ABC of side 2 cm.

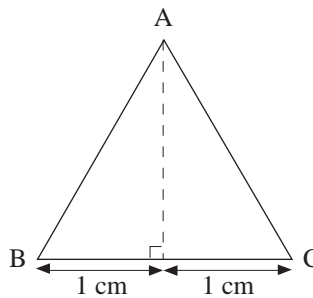

5. What is the length of the longest side of the sail of the boat?

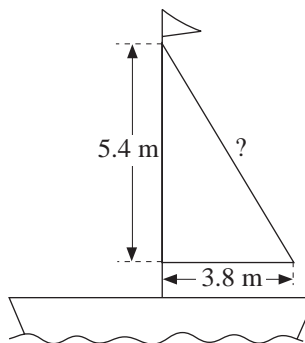

6. A ladder of length 4 metres rests with one end on horizontal ground and the other end against a vertical wall. If it reaches a point on the wall 3.5 metres above the ground, how far is its foot from the wall?

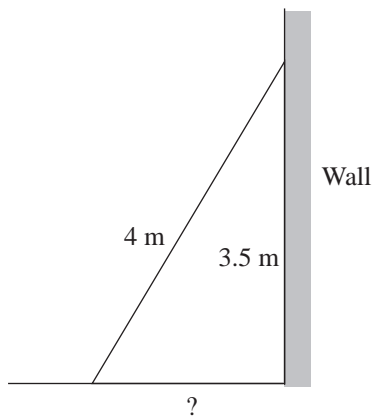

7. Find the height h of the structure.

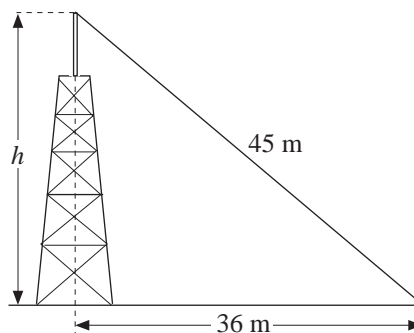

8. Which rectangle has the longer diagonal?

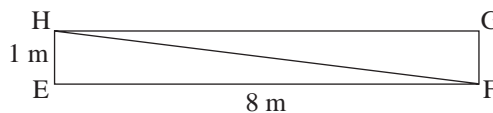
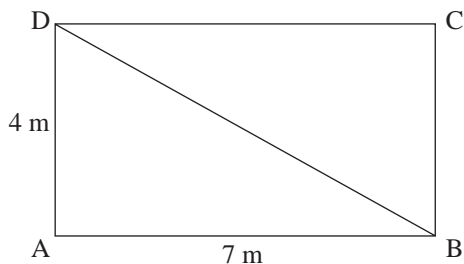

9. The diagram shows a pendulum AB of length 16 cm. AC is a vertical line passing through A such that $AC = 9.4$ cm and $\hat{ACB} = 90^\circ$. Find BC, giving your answer correct to 3 significant figures.

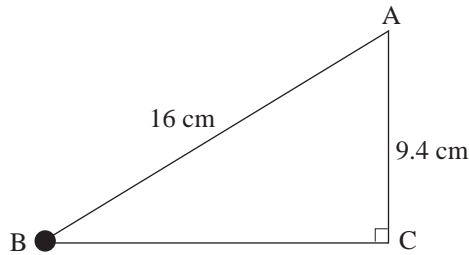

10. ABC is a right-angled triangle. $AB = 15$ cm and $AC = 17$ cm

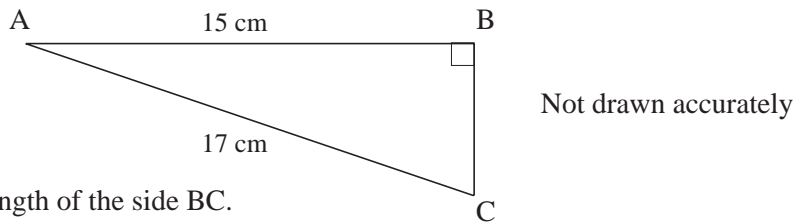

Calculate the length of the side BC.

(AQA)

4.3 Further Work with Pythagoras' Theorem

1. Calculate the lengths x and y in these diagrams. Give your answers correct to 1 decimal place where appropriate. All dimensions are given in cm.

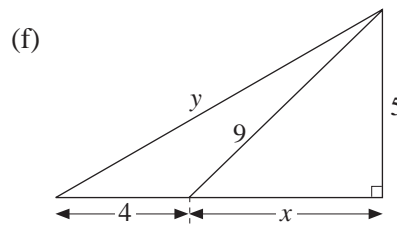
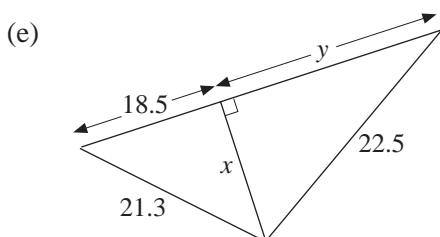
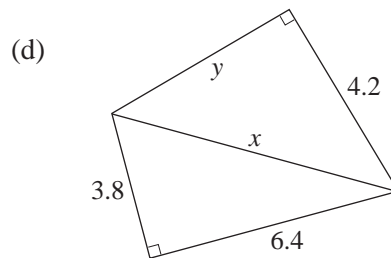
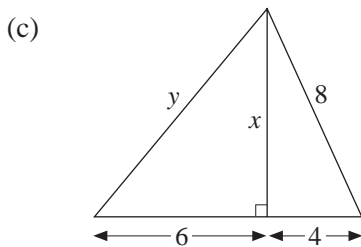
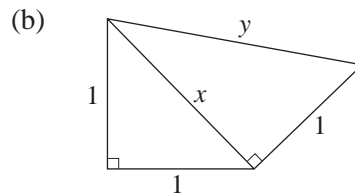
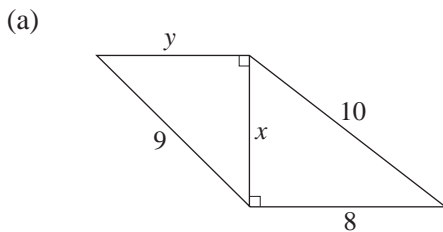

2. In the given diagram, calculate AB, giving your answer correct to 2 decimal places.

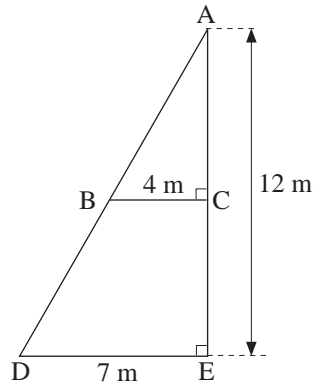

3. Calculate the length q .

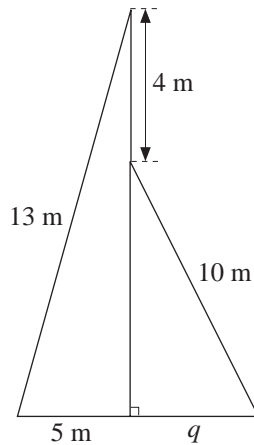

4. The diagonals of a rhombus are of lengths 9 cm and 13 cm. Find the lengths of its sides, giving your answer correct to 1 decimal place.

5. A ladder of length 6 metres was placed on horizontal ground and it leaned against a vertical wall. If the ladder reached 5.1 metres up the wall, how far from the wall was the foot of the ladder?

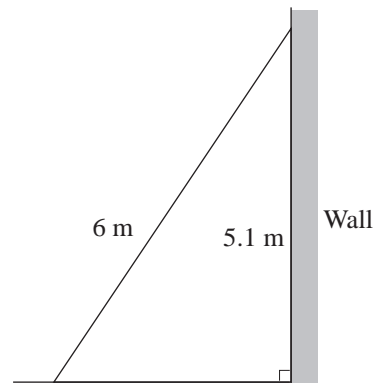

The foot of the ladder then slipped a distance of 0.5 metres from its original position. How far up the wall did the ladder reach? Give both answers to 1 decimal place.

6. Calculate PQ in the following diagrams. Give your answers correct to 1 decimal place.

(a)

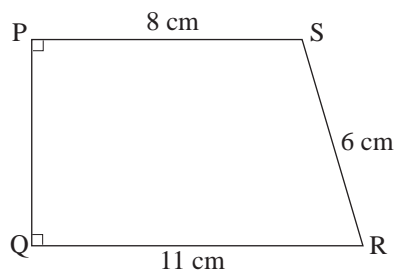

(b)

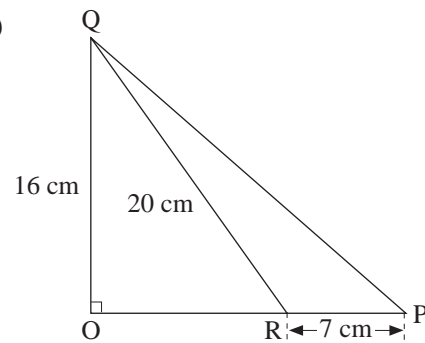

7. In $\triangle STU$, $SU = 24$ cm, $ST = 26$ cm,
 $\hat{TUS} = 90^\circ$ and V is the foot of the
 perpendicular from U to ST . Calculate
- TU
 - the area of $\triangle STU$
 - UV.

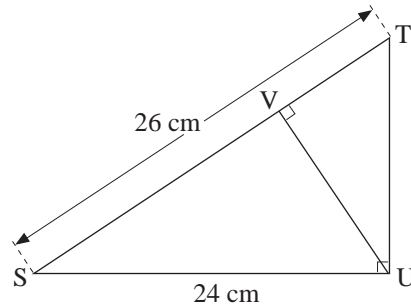

Give your answer to (c) correct to 1 decimal place.

4.4 Sine, Cosine and Tangent

1. For each of the following triangles, all dimensions are in cm. Find the tangent ratio of the shaded angle.

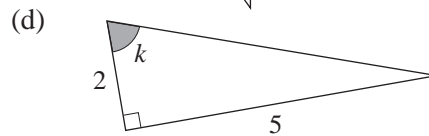
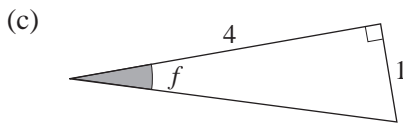
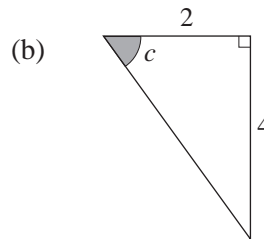
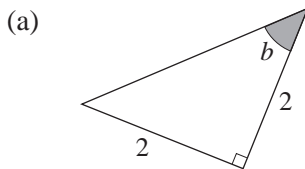

2. Find each of the following, giving your answer correct to 3 decimal places.

- | | | |
|-----------------------|-----------------------|-----------------------|
| (a) $\tan 36^\circ$ | (b) $\tan 42^\circ$ | (c) $\tan 55^\circ$ |
| (d) $\tan 17^\circ$ | (e) $\tan 68^\circ$ | (f) $\tan 73^\circ$ |
| (g) $\tan 67.4^\circ$ | (h) $\tan 75.5^\circ$ | (i) $\tan 81.2^\circ$ |
| (j) $\tan 89.3^\circ$ | (k) $\tan 16.9^\circ$ | (l) $\tan 26.2^\circ$ |

3. Find the size of angle x in each of the following. Give your answer correct to 1 decimal place.

- | | | |
|--------------------|----------------------|----------------------|
| (a) $\tan x = 0.3$ | (b) $\tan x = 0.4$ | (c) $\tan x = 0.8$ |
| (d) $\tan x = 1.3$ | (e) $\tan x = 1.5$ | (f) $\tan x = 2$ |
| (g) $\tan x = 2.5$ | (h) $\tan x = 3.3$ | (i) $\tan x = 4.5$ |
| (j) $\tan x = 5.8$ | (k) $\tan x = 100.4$ | (l) $\tan x = 233.5$ |

4. For each of the following triangles, all dimensions are in cm. Find the sine ratio of the shaded angle. Give your answer correct to 2 decimal places.

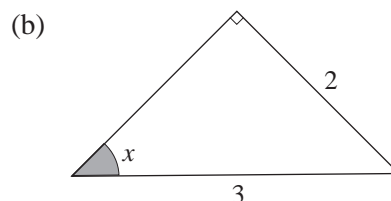
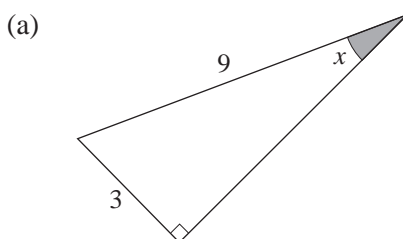

(c)

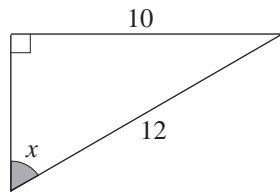

(d)

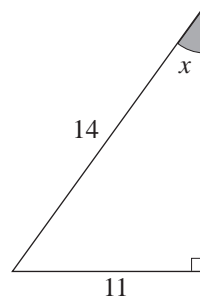

5. Find the value of each of the following. Give your answer correct to 3 decimal places.

(a) $\sin 22^\circ$

(b) $\sin 76^\circ$

(c) $\sin 19.6^\circ$

(d) $\sin 39.2^\circ$

(e) $\sin 61.3^\circ$

(f) $\sin 85.7^\circ$

(g) $\sin 44.9^\circ$

(h) $\sin 50.4^\circ$

(i) $\sin 67.1^\circ$

(j) $\sin 79.3^\circ$

(k) $\sin 81.2^\circ$

(l) $\sin 29.6^\circ$

6. Find the size of angle x in each of the following. Give your answer correct to 1 decimal place.

(a) $\sin x = 0.31$

(b) $\sin x = 0.27$

(c) $\sin x = 0.46$

(d) $\sin x = 0.64$

(e) $\sin x = 0.189$

(f) $\sin x = 0.986$

(g) $\sin x = 0.497$

(h) $\sin x = 0.721$

(i) $\sin x = 0.584$

(j) $\sin x = 0.842$

(k) $\sin x = 0.992$

(l) $\sin x = 0.999$

7. For each of the following triangles, all dimensions are in cm. Find the cosine ratio of the shaded angle. Give your answer correct to 2 decimal places.

(a)

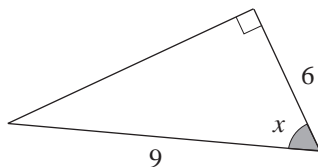

(b)

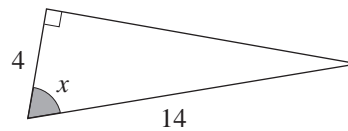

(c)

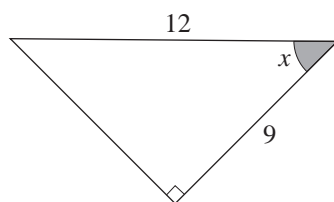

(d)

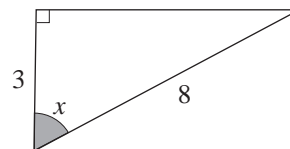

8. Find the value of each of the following. Give your answer correct to 3 decimal places.

(a) $\cos 29^\circ$

(b) $\cos 48^\circ$

(c) $\cos 30^\circ$

(d) $\cos 69^\circ$

(e) $\cos 80.2^\circ$

(f) $\cos 54.7^\circ$

(g) $\cos 79.3^\circ$

(h) $\cos 35.5^\circ$

(i) $\cos 43.8^\circ$

(j) $\cos 56.2^\circ$

(k) $\cos 61.2^\circ$

(l) $\cos 83.8^\circ$

9. Find the size of angle x in each of the following. Give your answer correct to 1 decimal place.

- | | | |
|----------------------|----------------------|----------------------|
| (a) $\cos x = 0.33$ | (b) $\cos x = 0.26$ | (c) $\cos x = 0.51$ |
| (d) $\cos x = 0.37$ | (e) $\cos x = 0.016$ | (f) $\cos x = 0.998$ |
| (g) $\cos x = 0.305$ | (h) $\cos x = 0.816$ | (i) $\cos x = 0.538$ |
| (j) $\cos x = 0.276$ | (k) $\cos x = 0.171$ | (l) $\cos x = 0.662$ |

10. Write expressions for

$$\sin \alpha, \cos \alpha, \tan \alpha$$

and

$$\sin \beta, \cos \beta, \tan \beta$$

in terms of a , b and c .

What do you notice about the results?

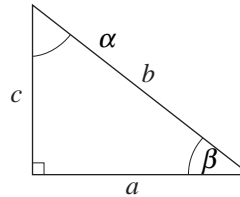

4.5 Finding Lengths in Right Angled Triangles

1. In each of the following find the length of y , giving your answer correct to 2 decimal places.

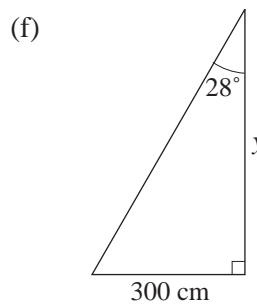
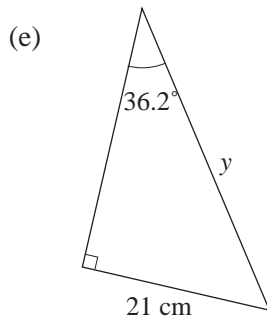
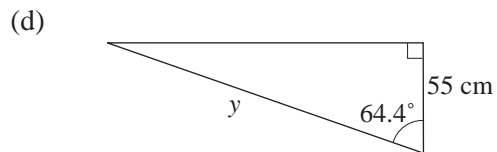
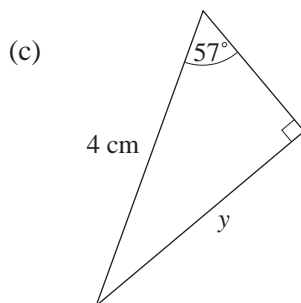
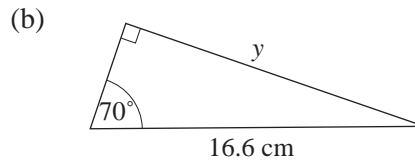
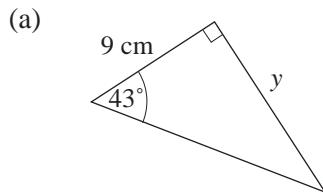

2. One end of a pole, 8 metres long, reaches a corner of the ceiling of a room.
 If the angle made by the pole with the horizontal is 35° ,
 what is the height of the ceiling?
 Give your answer correct to 2 significant figures.

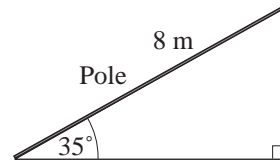

3. The length of the shadow of a vertical pole is 3.42 metres long when the rays of the sun are inclined at an angle of 40.5° to the horizontal.
 What is the height of the pole?
 Give your answer correct to 2 decimal places.

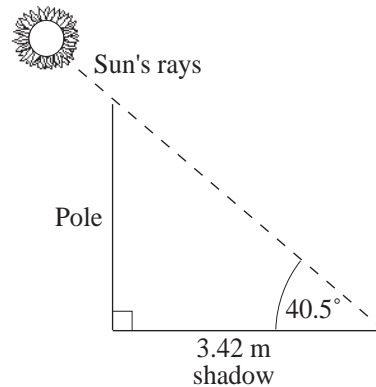

4. The diagram shows two banks of a river which are at different levels.
 Points P and Q are on opposite sides of the river such that a rope attached from P to Q makes an angle of 22° to the horizontal.

If $PQ = 70$ m, calculate :

- (a) the width of the river,
 (b) the difference in heights of the two banks.

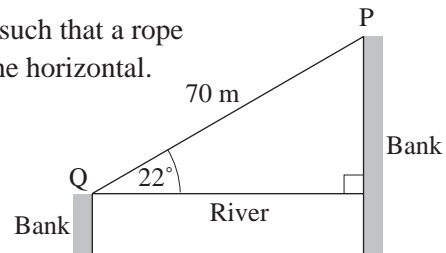

Give your answers correct to the nearest metre.

5. A path, 750 metres long, runs straight up the slope of a hill.
 If the angle made by the path with the horizontal is 16° ,
 find the height of the point at the top end of the path.
 Give your answer correct to 3 significant figures.

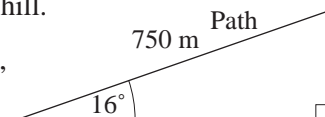

6. A ladder is placed on horizontal ground with its foot 2 metres from a vertical wall.
 If the ladder makes an angle of 50° with the ground, find:
 (a) the length of the ladder,
 (b) how far up the wall it reaches.
 Give your answers correct to 1 decimal place.

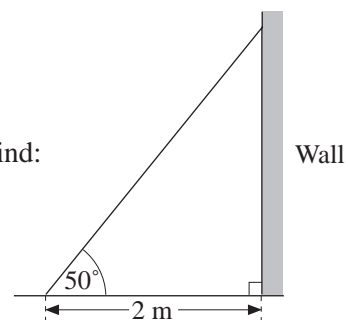

7. One end of a rope of length 45 metres is tied to a point on the ground and the other end to the top of an antenna.
 When the rope is taut, its inclination to the horizontal is 48° .
 Find, correct to 3 significant figures, the distance of the top of the antenna from the ground.

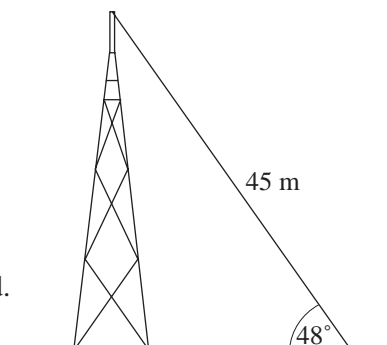

8. A wire 18 metres long runs from the top of a pole to the ground as shown in the diagram. The wire makes an angle of 35° with the ground.

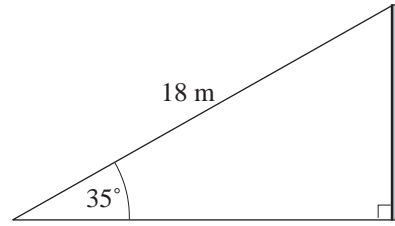

Calculate the height of the pole.

Give your answer to a reasonable degree of accuracy.

(NEAB)

9. ABC is a right-angled triangle.

$AB = 60 \text{ m}$

Angle $BAC = 32^\circ$

Find the length of BC.

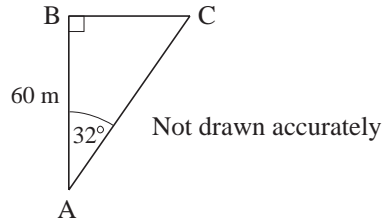

(AQA)

10. ABC and ADE are similar triangles.

$BC = 1.5 \text{ m}$, $DE = 9 \text{ cm}$, $AB = 2 \text{ cm}$

Calculate the length of BD.

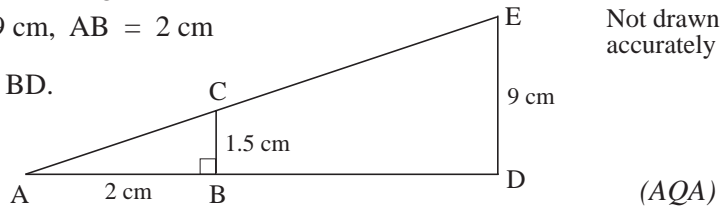

(AQA)

4.6 Finding Angles in Right Angled Triangles

1. In each of the following find angle x , giving your answer correct to 1 decimal place.

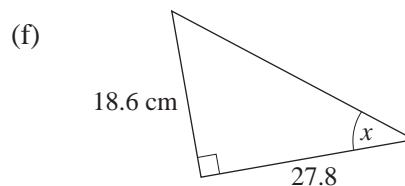
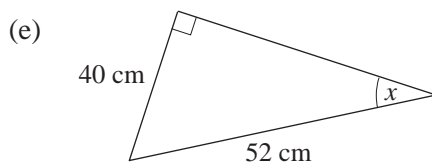
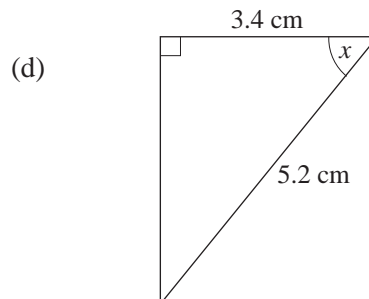
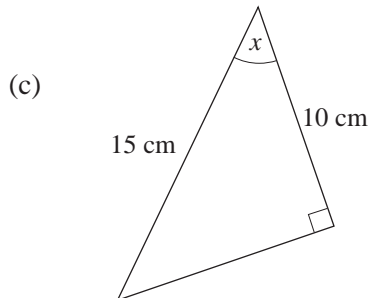
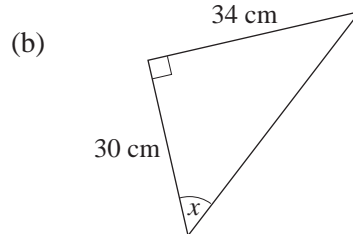
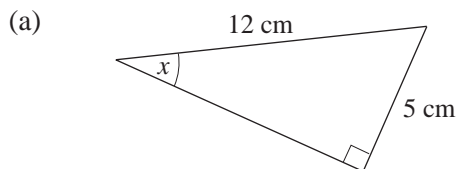

2. The diagram shows a roofing frame ABCD.
 $AB = 7\text{ m}$, $BC = 5\text{ m}$, $DB = 3\text{ m}$, angle $ABD = \text{angle } DBC = 90^\circ$.

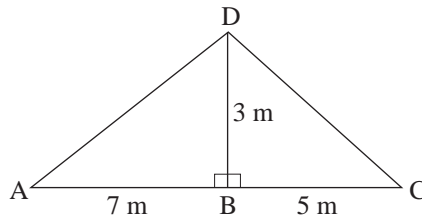

- (a) Calculate the length of AD.
 (b) Calculate the size of angle DCB.

3. From the top of a building a man sights a pedestrian on the street below at a distance of 48 metres away. The pedestrian is 34.5 metres away from the foot of the building. Find the angle of depression of the pedestrian from the man, correct to the nearest degree.

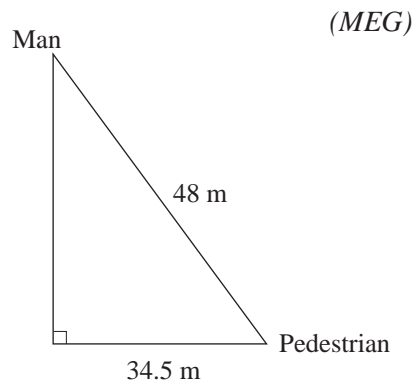

4. Find all unknown angles and lengths for each triangle. Give your answers correct to the nearest cm or degree.

