

14 Loci and Transformations

14.1 Drawing and Symmetry

1. Draw accurately rectangles with the following sizes:

- (a) 4 cm by 5 cm (b) 9 cm by 2.5 cm

2. Make accurate drawings of each of the shapes below and answer the question below each shape.

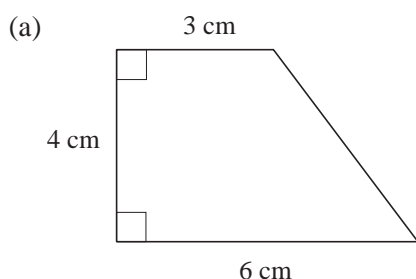

What is the length of the sloping side?

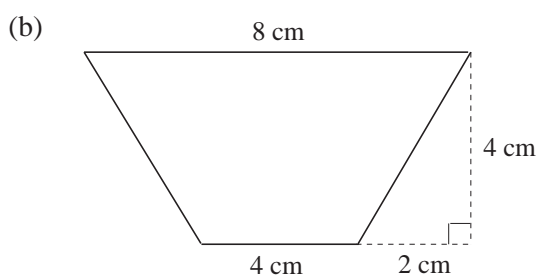

What is the length of one of the sloping sides?

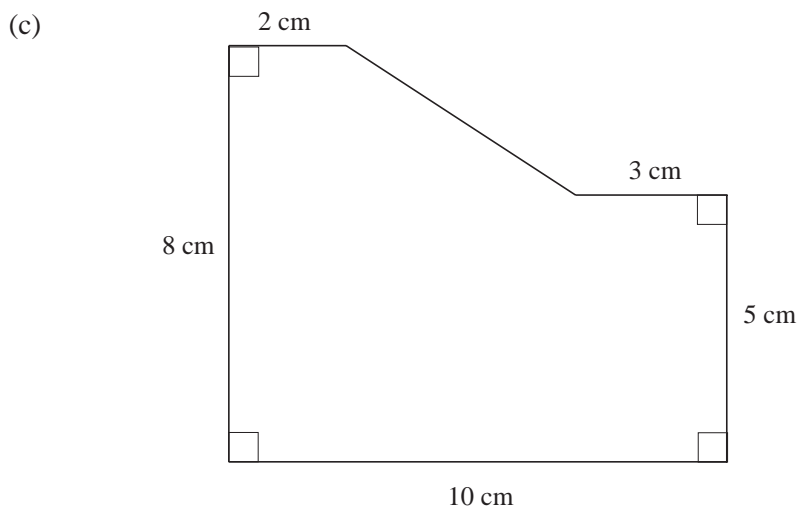

What is the length of the longest straight line which can be drawn inside the shape?

3. Each shape below includes a semi-circle. Make an accurate drawing of each shape and state the radius of the semi-circle.

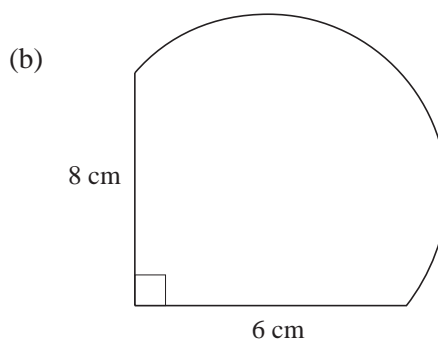
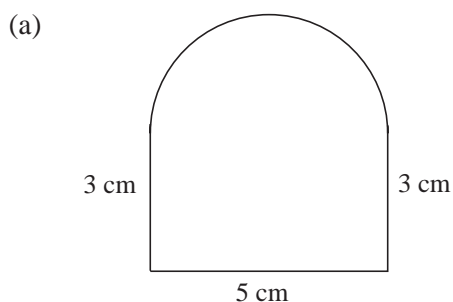

4. For each shape below:

- (i) state the order of rotational symmetry,
- (ii) copy the shape and draw any line of symmetry.

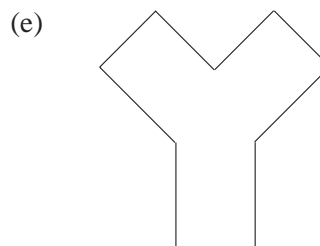
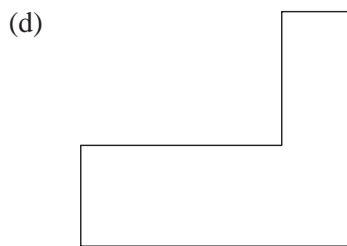
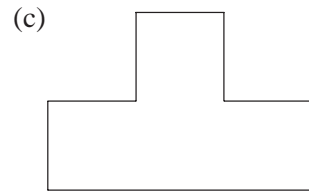
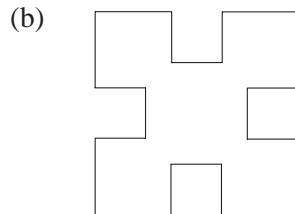
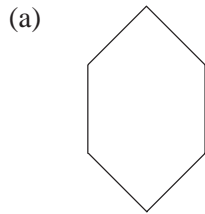

5.

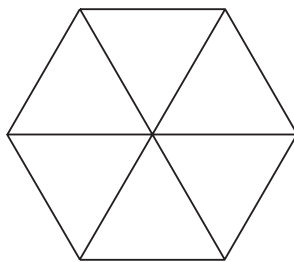

Make 4 copies of this shape. Shade part of the shape to produce shapes with:

- (a) exactly 2 lines of symmetry
- (b) exactly 1 line of symmetry
- (c) rotational symmetry of order 1
- (d) rotational symmetry of order 2.

6. Which of the shapes below have:

- (a) rotational symmetry of order 1
- (b) no lines of symmetry
- (c) more than 2 lines of symmetry
- (d) rotational symmetry of order 2
- (e) rotational symmetry of order greater than 2?

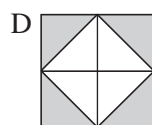
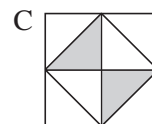
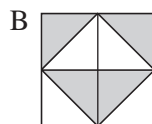

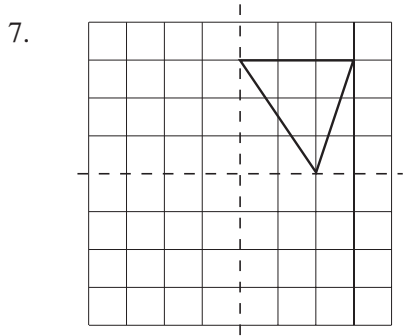

The diagram shows part of a design.

The dotted lines are lines of symmetry of the whole design.

- (a) Copy and complete the design.
- (b) Write down the order of the rotational symmetry of the completed design.

(OCR)

8. The properties of 4 quadrilaterals are shown in the table.

<i>Shape</i>	<i>Lines of symmetry</i>	<i>Order of rotational symmetry</i>	<i>Diagonals of equal length</i>
A	4	4	Yes
B	2	2	Yes
C	2	2	No
D	0	2	No

Copy and complete these statements by filling in the letter in each case.

- (a) A square is described by shape
- (b) A parallelogram is described by shape
- (c) A rectangle is described by shape

(AQA)

9. (a) Write down the name of this quadrilateral.

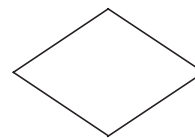

(b) Three of these statements are true for a kite.

On a copy of the diagram, draw arrows from the statements that are true to the picture of the kite. One of them has been done for you.

- Two pairs of sides are equal
- It has 2 lines of symmetry
- It has rotational symmetry of order 2
- The diagonals cross at right angles
- Opposite angles are equal
- One pair of opposite angles are equal

(AQA)

14.2 Scale Drawings

1. The scale drawing of a shop, shown below, has been drawn on a scale of 1 : 200.

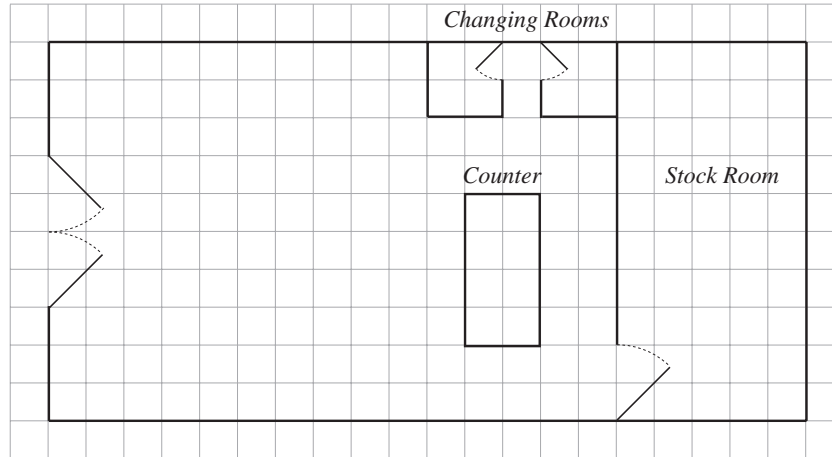

Find :

- the actual sizes of the stock room and each changing room.
 - the area of the counter
 - the width of the shop entrance.
2. A rough sketch is shown below of the ground floor of a house.

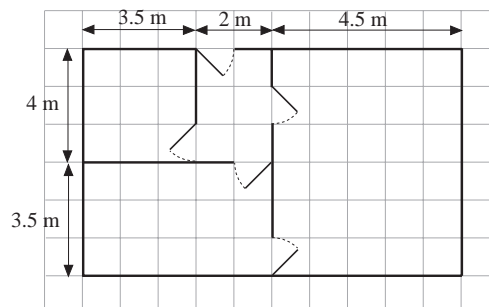

Use the information given to produce a scale drawing with a scale of 1 : 200.

3. The drawing opposite represents a scale drawing of a garden.

It is drawn with a scale of 1 : 120.

Find:

- the dimensions of the shed
- the area of the vegetable garden
- the dimensions of the flower bed
- the radius of the pond.
- the area of the land grassed.

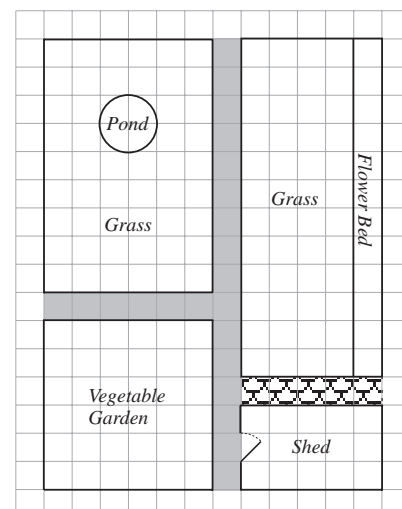

4. A room is rectangular, with width 5 m and length 6 m. What would be the size of the rectangle on a scale drawing with a scale of:
- (a) 1 : 50 (b) 1 : 100 (c) 1 : 200?

5. The sketch drawing shows the plan of a field.

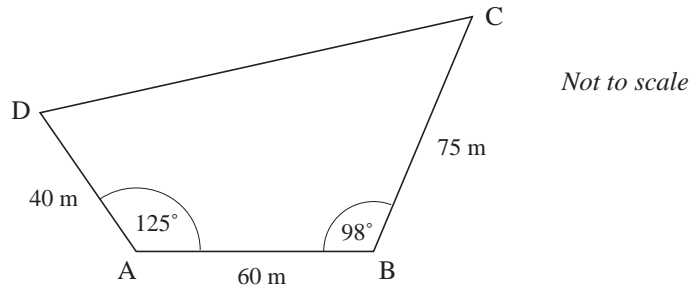

Using a scale of 1 centimetre to 10 metres, make an accurate scale drawing.

Write down the length of the side CD to the nearest metre.

(MEG)

6. The scale drawing shows the position of an airport tower, T, and a radio mast, M. 1 cm on the diagram represents 20 km.

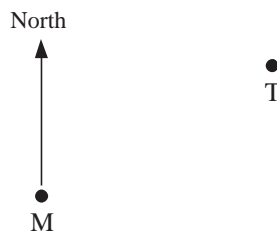

- (a) (i) Measure, in centimetres, the distance TM.
 (ii) Work out the distance in km of the airport tower from the radio mast.
- (b) (i) Measure and write down the bearing of the airport tower from the radio mast.
 (ii) Write down the bearing of the radio mast from the airport tower.

A plane is 80 km from the radio mast on a bearing of 220° .

- (c) On a copy of the diagram, plot the position of the plane, using a scale of 1 cm to 20 km.

(LON)

7.

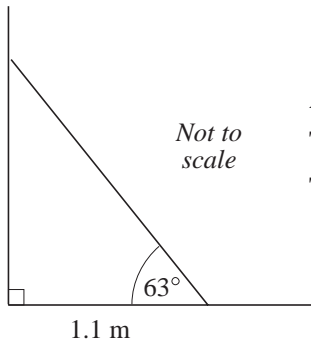

A tall fence is supported by a post at an angle as shown.
 The foot of the post is 1.1 m from the fence.
 The post makes an angle of 63° with the ground.

- (a) Complete a scale drawing to show the angled post. The fence and the ground have been drawn for you to copy.
 Use a scale of 4 cm to 1 metre.

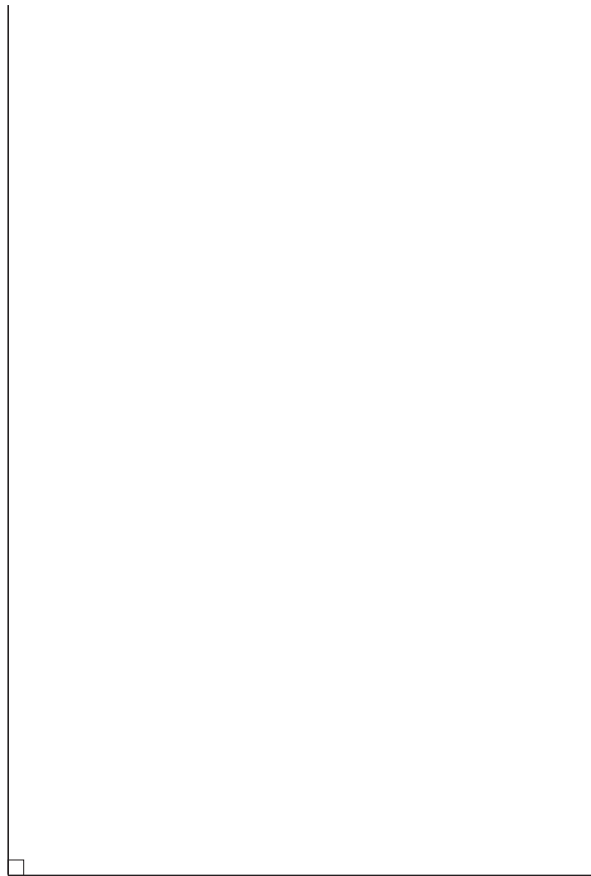

- (b) How far up the fence does the post reach?

(OCR)

8. The diagram shows a rough sketch of a triangular field.

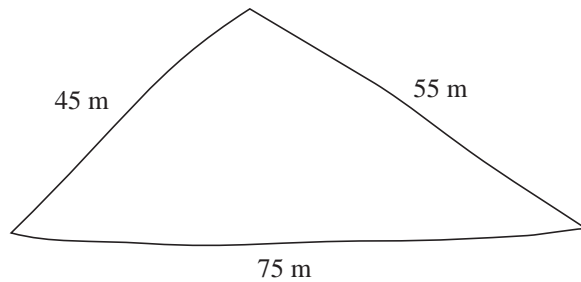

- (a) Using ruler and compasses only, make an accurate scale drawing of the field. Use a scale of 1 cm to represent 10 m. You **must** show clearly all your construction arcs.
- (b) The length of one side of the field is 75 metres. This length is measured to the nearest metre. What is the smallest possible length of this side?

(AQA)

14.3 Constructing Triangles and Other Shapes

1. Draw triangles with sides of the following lengths:
- (a) 12 cm, 8 cm, 7 cm (b) 8 cm, 5 cm, 6 cm.
2. Draw accurately the triangles shown in the rough sketches below and then answer the question about each sketch.

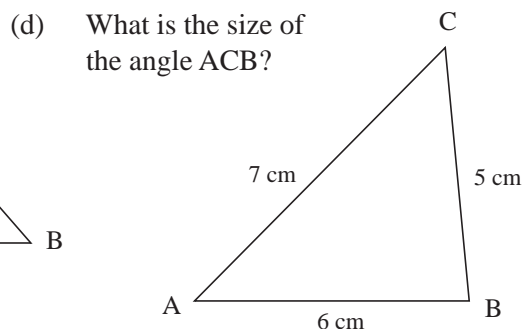
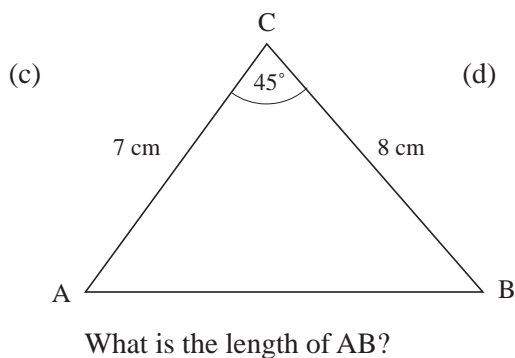
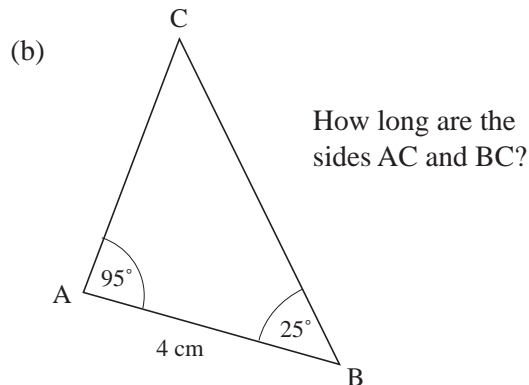
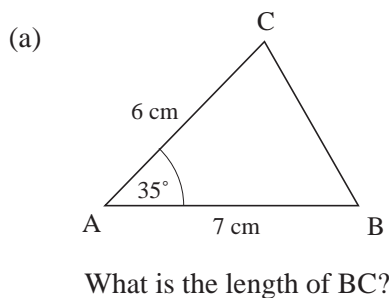

3. Draw accurately an equilateral triangle with sides of length 6 cm.
4. An isosceles triangle has a base of length 8 cm and base angle of 37° .
Make an accurate drawing of the triangle and use it to estimate the lengths of the other sides of the triangle.
5. An isosceles triangle has 2 sides of length 6 cm and one side of length 10 cm.
Find the sizes of all the angles in the triangle.
6. For each rough sketch below, draw accurately *two* possible triangles.

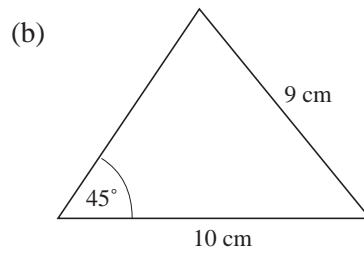
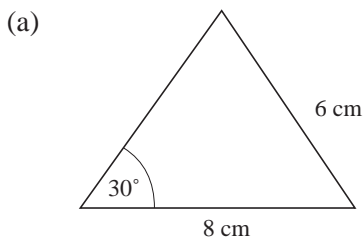

7. Draw a rhombus, ABCD, with $AB = 6$ cm and $\hat{DAB} = 40^\circ$. What are the lengths of the diagonals?

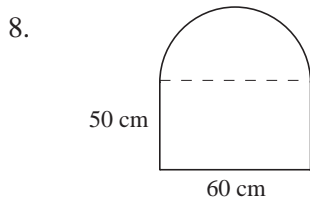

A small window is made of a semicircle of radius 30 cm and a straight section of height 50 cm.

Construct an accurate drawing of this window.

14.4 Enlargements

1. Copy the diagrams below on to squared paper. Enlarge each shape with scale factor 2, using the point marked as the centre of enlargement.

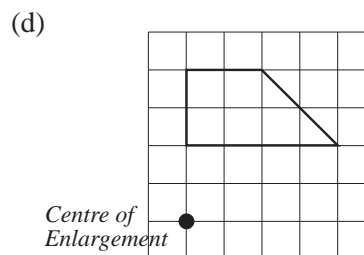
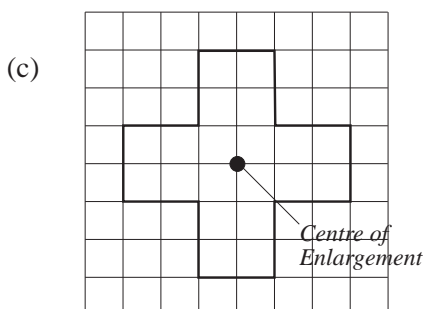
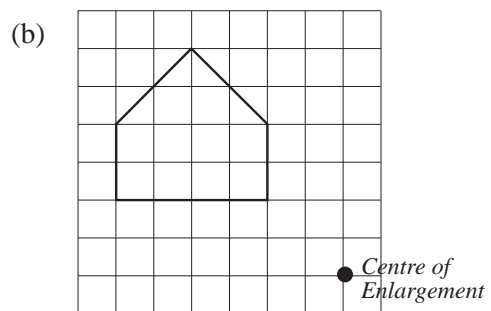
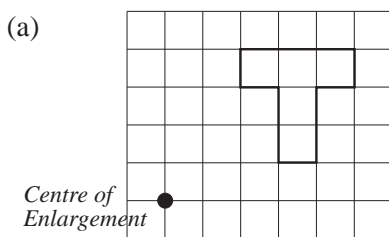

2. In each diagram below, the smaller shape has been enlarged to obtain the larger shape. For each example, copy the diagram on to squared paper, state the scale factor and find the centre of enlargement.

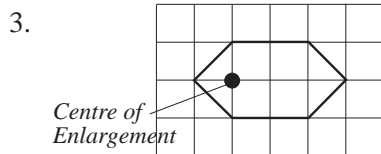
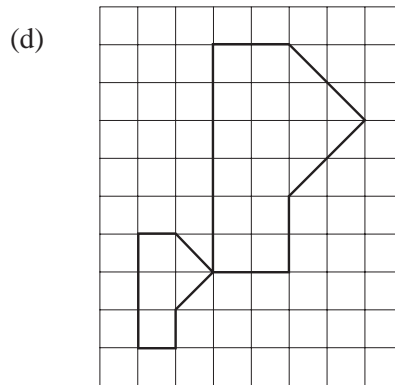
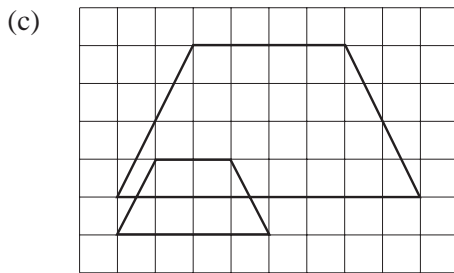
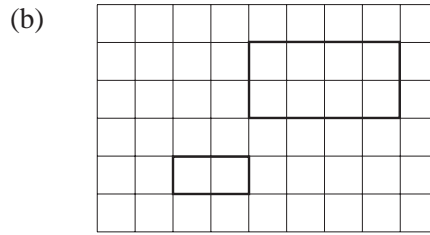
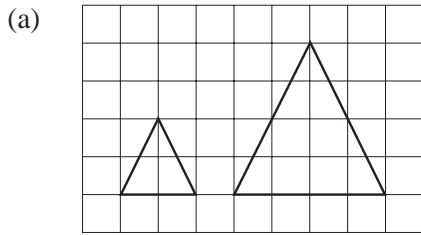

Copy the diagram opposite and enlarge it with a scale factor of

- (a) 2 (b) 3.

4. On a copy of the grid below, enlarge the shaded shape by a scale factor of 3. Start your enlargement at point B.

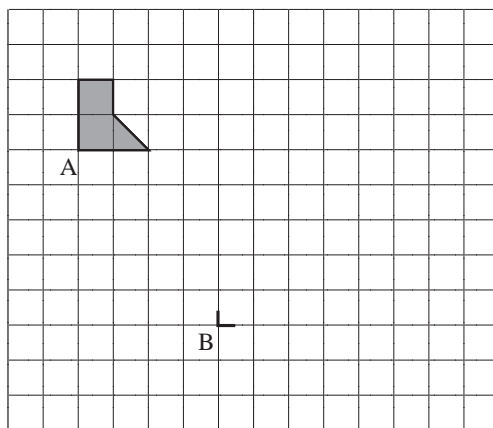

(LON)

5. Enlarge the shape with scale factor 2 and centre (0, 3).

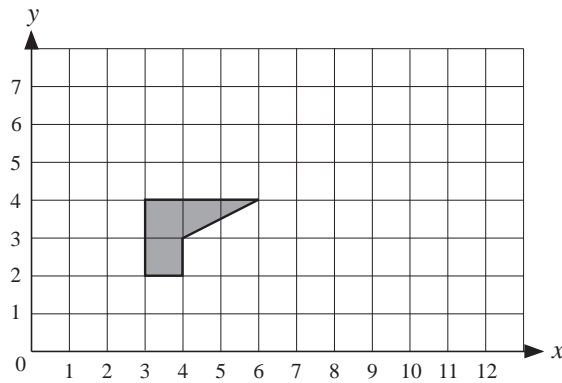

(SEG)

6. Enlarge the shaded figure, using scale factor 3 and centre of enlargement E.

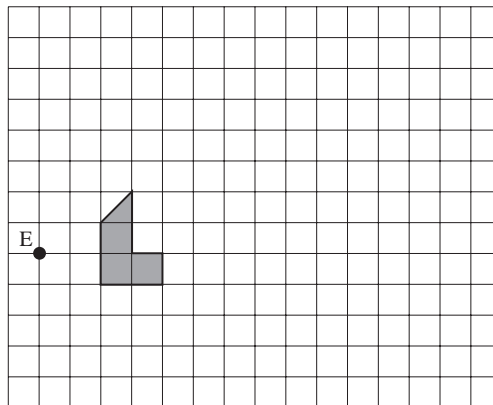

(MEG)

7. In the diagram, triangle T is an enlargement of triangle S from a centre C.

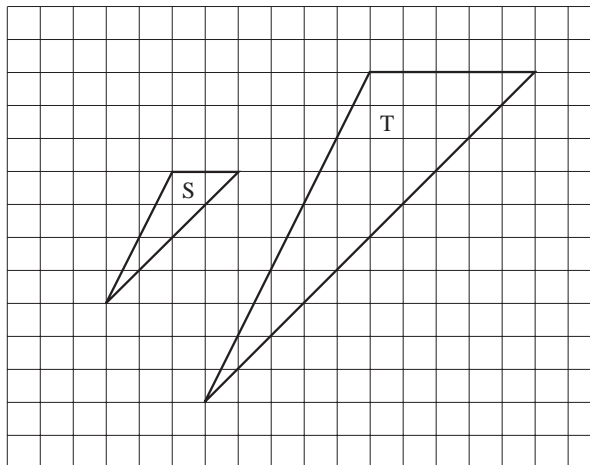

- (a) On a copy of the diagram, mark and label the centre of enlargement C.
- (b) Write down the scale factor of the enlargement.

(MEG)

8. On a copy of the grid, draw an enlargement of this shape. Use a scale factor of 3.

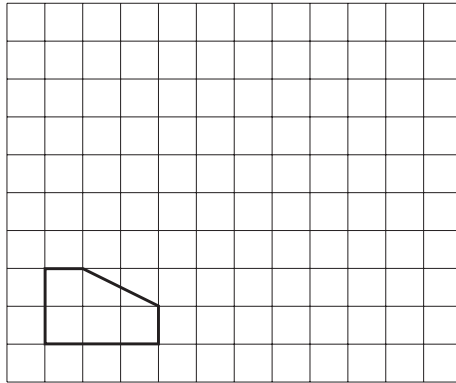

(OCR)

9. A shape has been drawn on a grid of one centimetre squares.

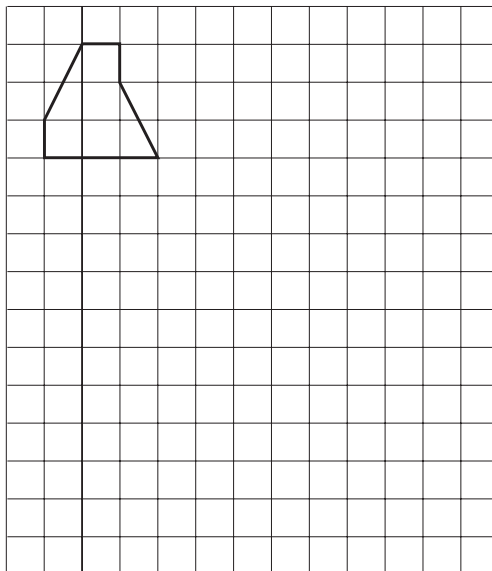

- (a) Work out the area of the shape.
 (b) On a copy of the grid, enlarge the shape with a scale factor of 2.

(OCR)

14.5 Reflections

1. Copy each diagram below and draw the reflection of each object.

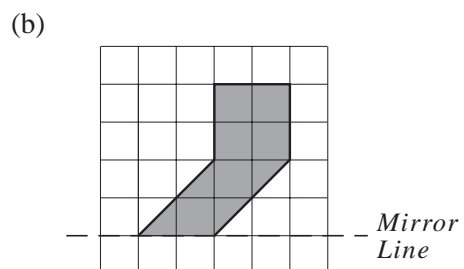
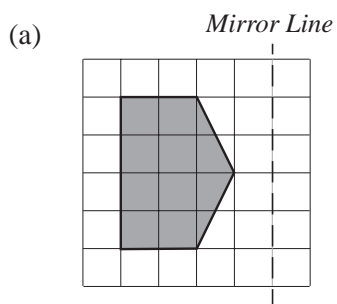

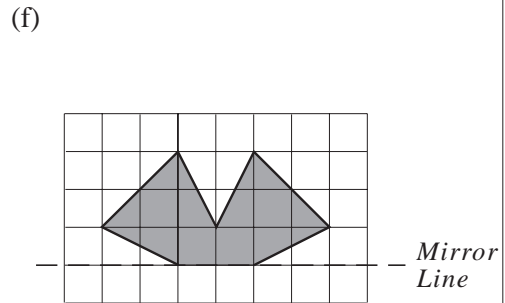
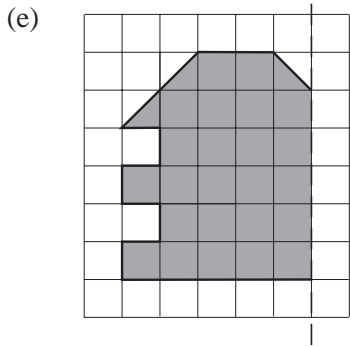
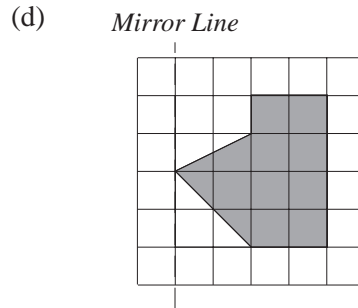
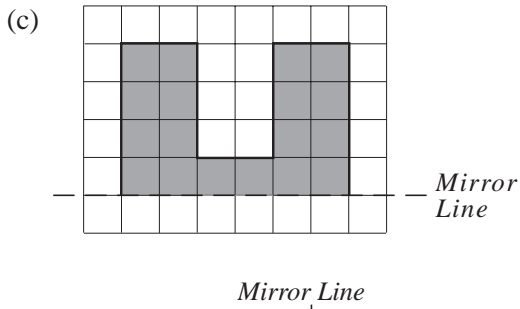

2. Copy the diagram below.

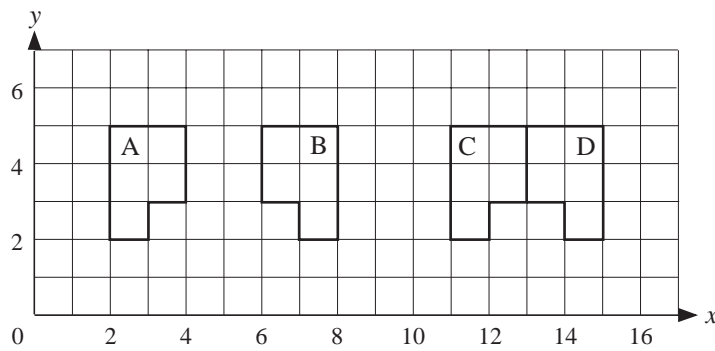

Draw the mirror line for each of the following reflections.

- (a) $A \rightarrow B$ (b) $A \rightarrow D$ (c) $B \rightarrow C$ (d) $C \rightarrow D$

3. Copy the diagram opposite.

Draw the mirror line for each of the following reflections:

- (a) $A \rightarrow B$
 (b) $A \rightarrow D$
 (c) $B \rightarrow C$
 (d) $C \rightarrow D$

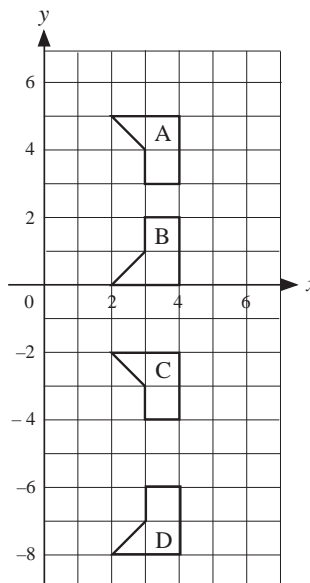

4.

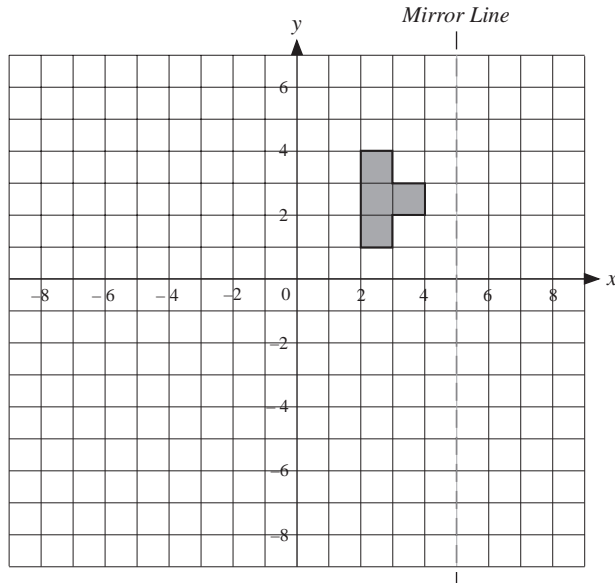

- (a) Copy the axis and the shape shown opposite.
- (b)
 - (i) Reflect the shape in the mirror line shown.
 - (ii) Reflect the new shape in the x -axis.
 - (iii) Reflect the new shape in the y -axis.
 - (iv) Reflect the new shape in the x -axis.

(c) Describe two reflections needed to take the shape defined in (iv) above back to the original shape.

5. Reflect each of the shapes below in the mirror line shown.

(a) *Mirror Line*

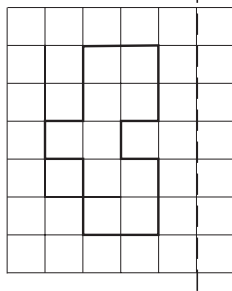

(b)

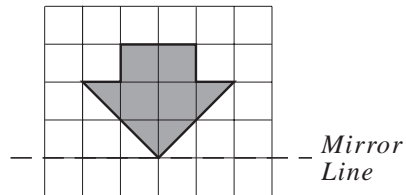

6. The diagram shows a triangle drawn on a centimetre square grid.

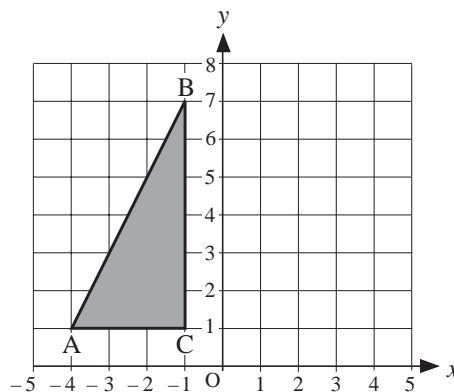

- (a) Write down the coordinates of A.
- (b) On a copy of the diagram, draw the reflection of the triangle in the y -axis. (AQA)

14.6 Construction of Loci

1. The line AB is 5 cm long. Draw the locus of a point which is always 2 cm from the line AB.

2. (a) Copy the diagram opposite.
 (b) Construct the locus of a point which is equidistant from both lines.

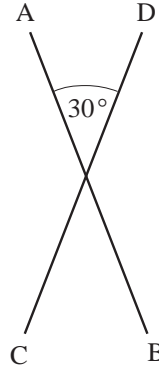

3. Two oil rigs, A and B, are in the sea near the port of C.

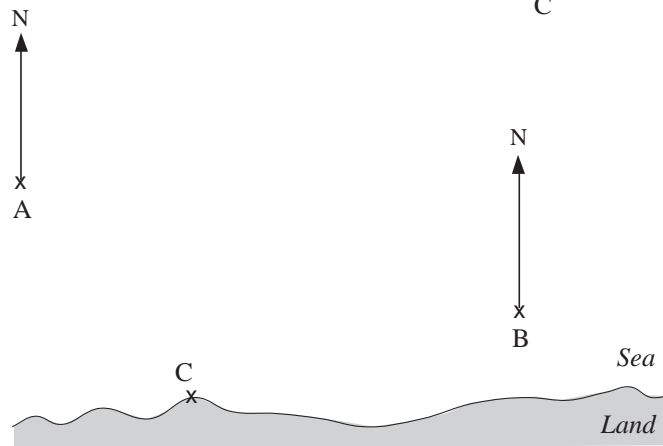

- (a) A third oil rig is the same distance from A and from B. Copy the diagram and construct the locus of possible positions of the third oil rig on the diagram.
 (b) The third oil rig, D, is also the same distance from C as it is from A and B. Mark with a cross the position of D.

(SEG)

4. The diagram shows a field, ABCD, drawn to a scale of 1 cm to 10 m. Treasure is hidden in the field.

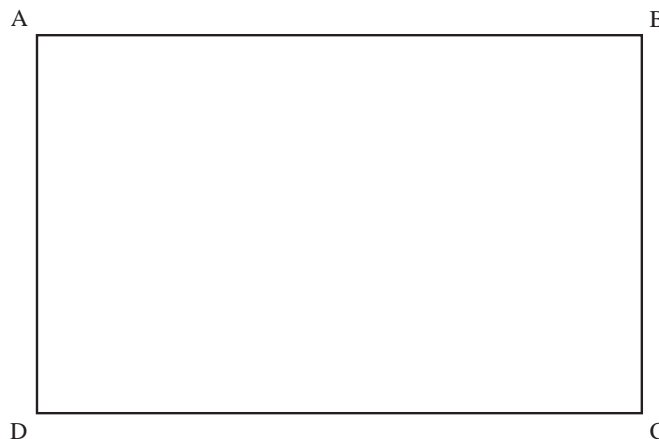

- (a) The treasure is at equal distances from the sides, AB and AD.
Copy the diagram and construct the locus of points for which this is true.
- (b) The treasure is also 60 m from the corner, C. Construct the locus of points for which this is true.
- (c) Mark with an X the position of the treasure.

(SEG)

5. The diagram below is a scale drawing of the floor of a room.
In the diagram, 2 cm represents 1 m.
X marks the position of an electric socket.

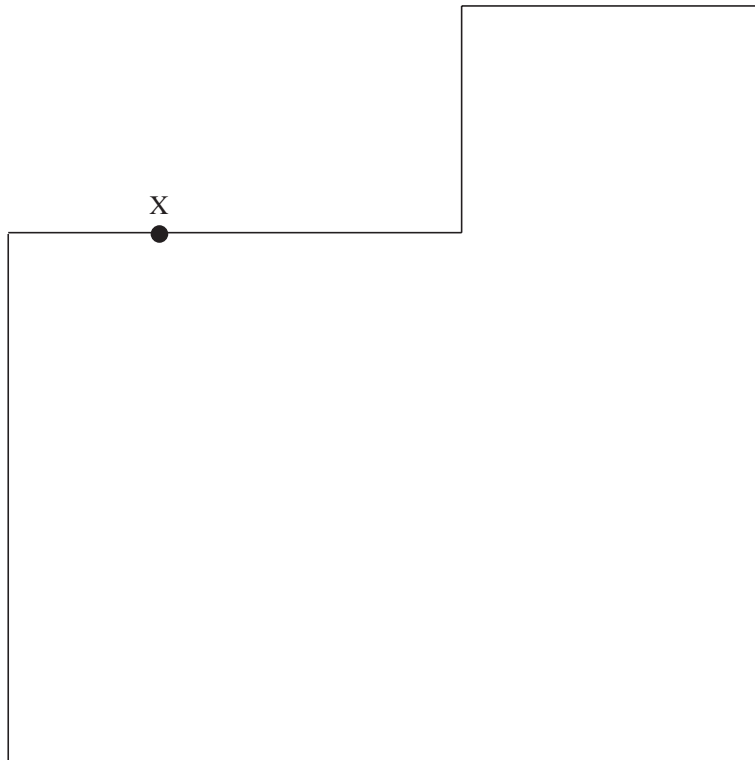

A vacuum cleaner is attached by a cable to the socket and can clean the floor up to 3 metres from the socket.

Copy the diagram and shade the part of the floor which can be cleaned by the vacuum cleaner.

(MEG)

6. Jason has to sail his ship between two rocks so that his ship is always the same distance from Point A on the first rock and Point B on the second rock.
The diagram on the following page shows the rocks.

On a copy of the diagram, construct accurately the path along which Jason must sail his ship.



7.

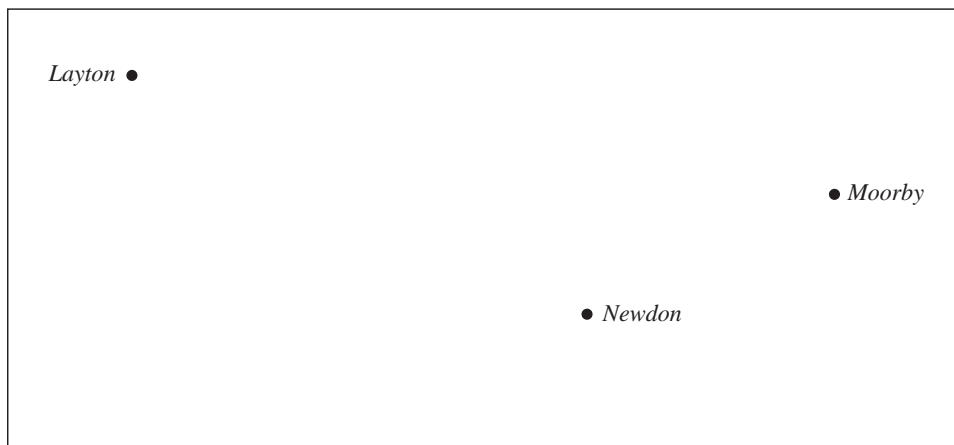

The map above, drawn to a scale of 4 cm to represent 1 km, shows the positions of three villages, *Layton*, *Moorby* and *Newdon*.

Simon's house is the same distance from *Moorby* as it is from *Layton*.

The house is also less than $\frac{3}{4}$ km from *Newdon*.

Draw a copy of the map and mark on your drawing the possible positions of Simon's house. Show your construction lines clearly.

(MEG)

8. Signals from a radio mast, M, can be received up to a distance of 100 km. Use a scale drawing of 1 cm to represent 20 km to answer the following questions.

(a) Shade the region in which signals from the radio mast can be received.

The distance of a helicopter from the radio mast is 70 km, correct to the nearest kilometre.

(b) Write down

(i) the maximum distance the helicopter could be from the radio mast

(ii) the minimum distance the helicopter could be from the radio mast.

(LON)

9.



The diagram represents a box which is to be moved across a floor XY.

$AD = 30$ cm and $AB = 20$ cm.

First the box is rotated about the point A so that BC becomes vertical. Then the box is rotated about the new position of the point B so that CD becomes vertical.

- (a) Copy the diagram and draw the locus of the point C.
- (b) Calculate the maximum height of C above the floor. Give your answer correct to one decimal place.
(A measurement from the scale drawing is unacceptable.)

(LON)

10. (a) (i) Draw a straight line, AB, 8 cm long.
(ii) Draw the locus of points, P, which lie above the line AB such that the area of triangle ABP is 12 cm^2 .
- (b) On the same diagram, construct the locus of points, Q, which lie above the line AB such that angle AQB is 90° .
- (c) Hence draw all triangles ABC which have C above AB, an area of 12 cm^2 and an angle of 90° .

(MEG)

11. The diagram shows the wall of a house drawn to a scale of 2 cm to 1 m. A dog is fastened by a lead 3 m long to a point X on a wall.

On a copy of the diagram shade the area that the dog can reach.

Scale: 2 cm to 1 m

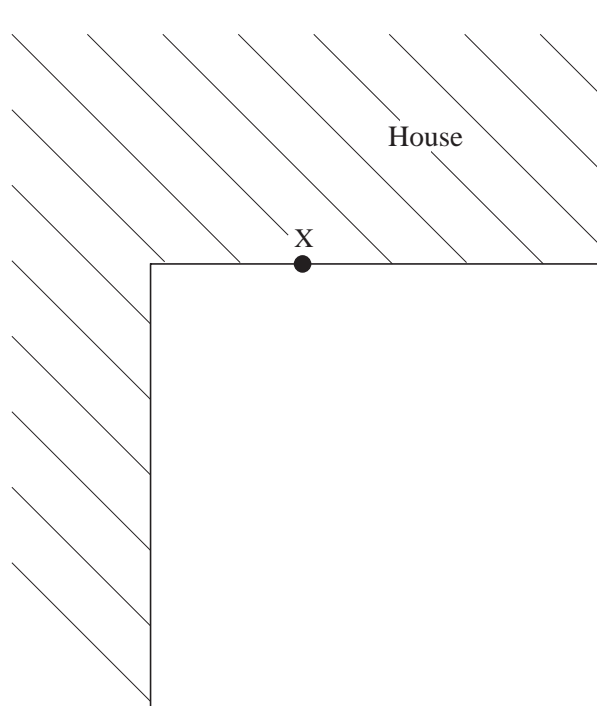

(OCR)

12. The diagram shows an L shape.

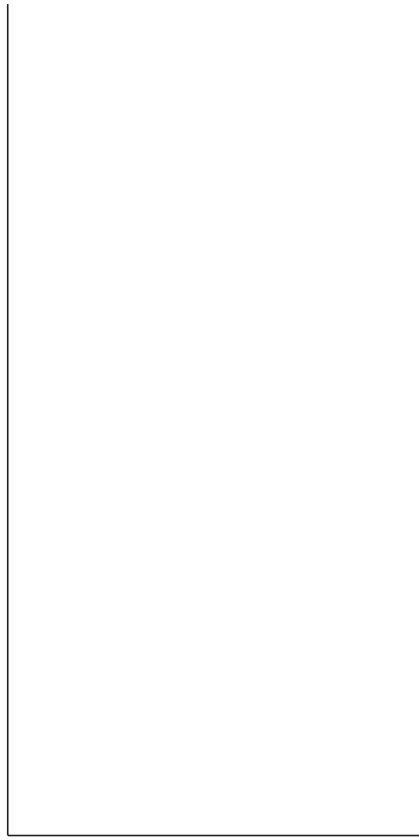

On a copy of the diagram, draw the locus of all points 2 cm from the L shape.

(AQA)

13. The diagram shows a quadrilateral PQRS.

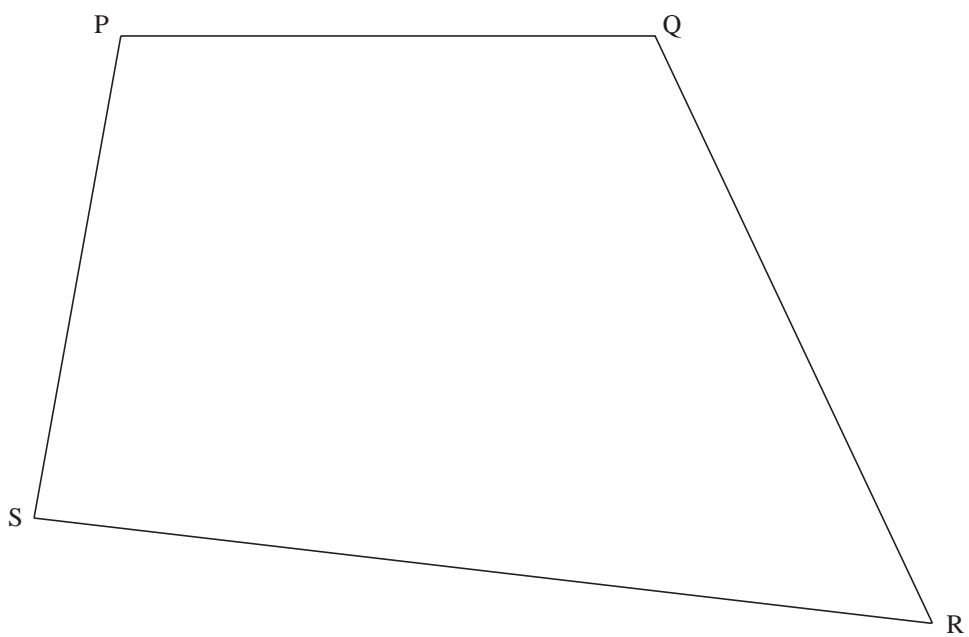

- (a) On a copy of the diagram, draw the locus of points that are the same distance from P as from Q.

- (b) Shade the region inside the quadrilateral which is less than 7 cm from S and nearer to Q than to P.

(AQA)

14.7 Enlargements which Reduce

1. For each pair of objects, state the scale factor of the enlargement which produces the smaller image from the larger one.

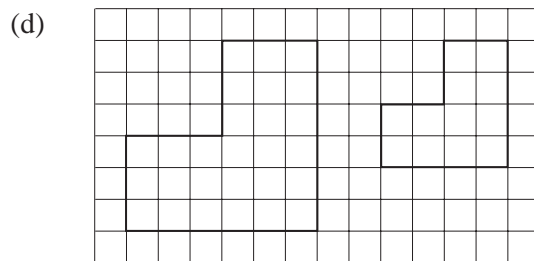
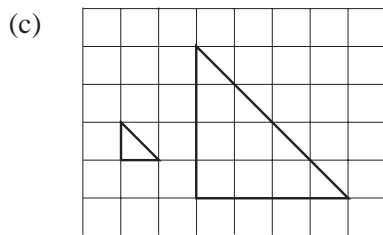
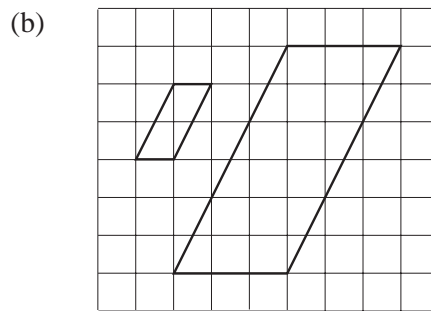
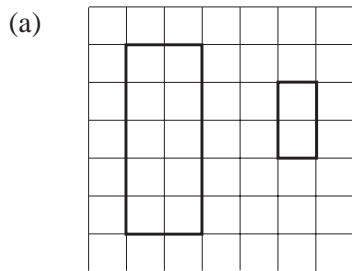

2. For each pair of objects below, the smaller shape has been obtained from the larger shape by an enlargement. For each example, state the scale factor and give the coordinates of the centre of enlargement.

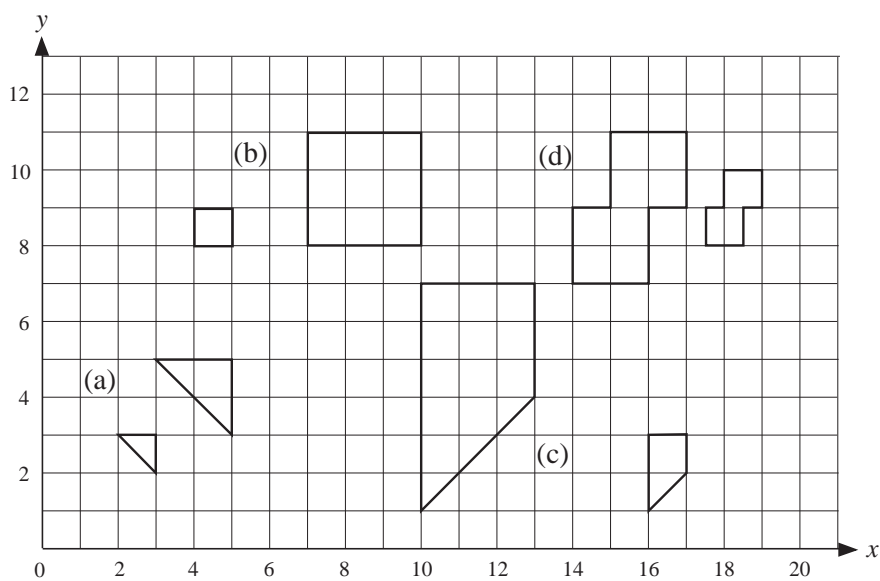

3. Copy each shape and enlarge using the given centre of enlargement and the specified scale factor.

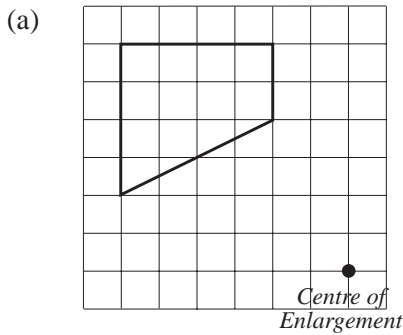

Scale factor $\frac{1}{2}$

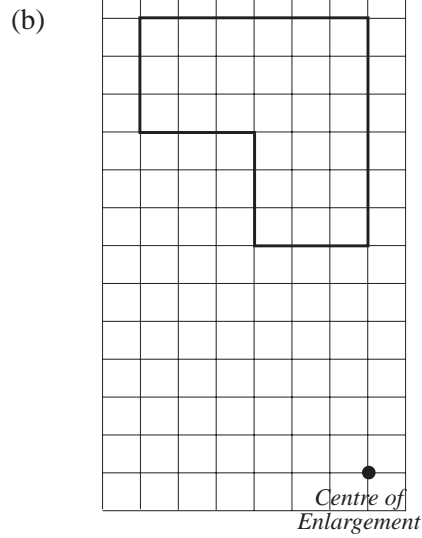

Scale factor $\frac{1}{3}$

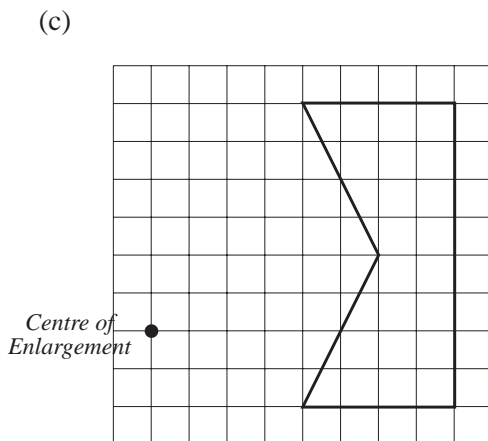

Scale factor $\frac{1}{2}$

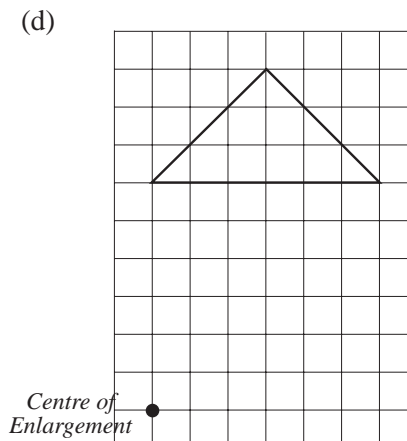

Scale factor $\frac{2}{3}$

4. The larger rectangle is reduced in size to the smaller rectangle.

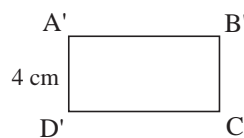
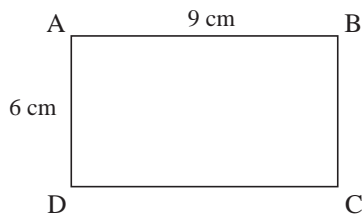

- (a) What is the scale factor of the enlargement?
 (b) What is the length of $A'B'$?

5. Each diagram below shows a shape and its image after enlargement. In each case, state the scale factor and find the unknown lengths in the image.

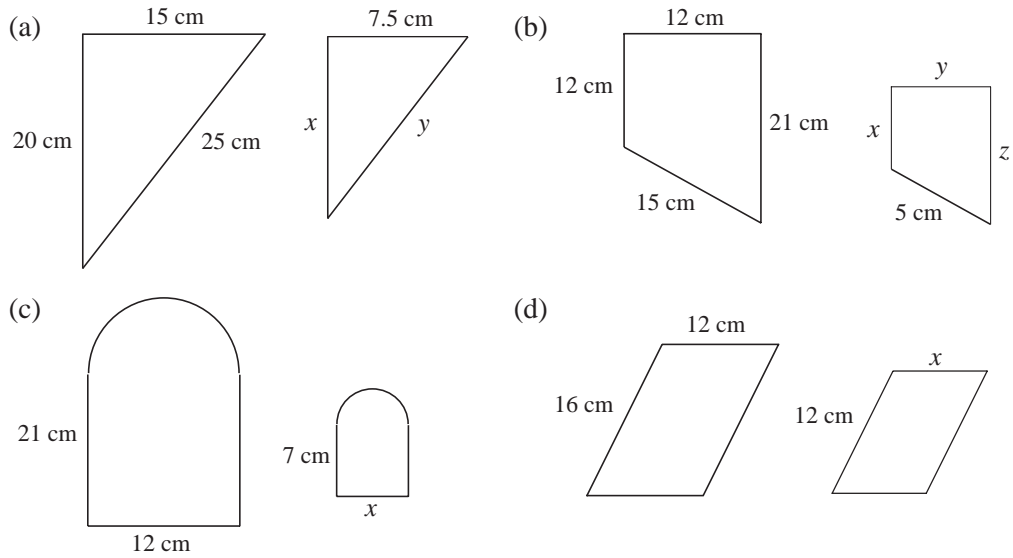

6. Shape A is shown in the diagram. Shape A is enlarged to obtain the shape B. One side of shape B has been drawn.

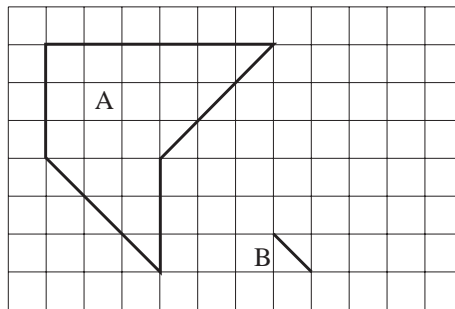

- (a) Write down the scale factor of the enlargement.
 (b) Copy the drawing and complete the shape B on your diagram.

(LON)

14.8 Further Reflections

1. Copy the diagrams below and draw the reflection of each shape in the mirror line.

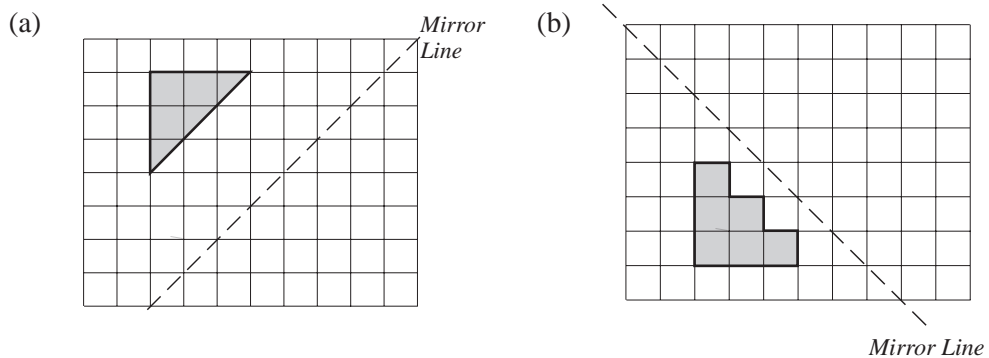

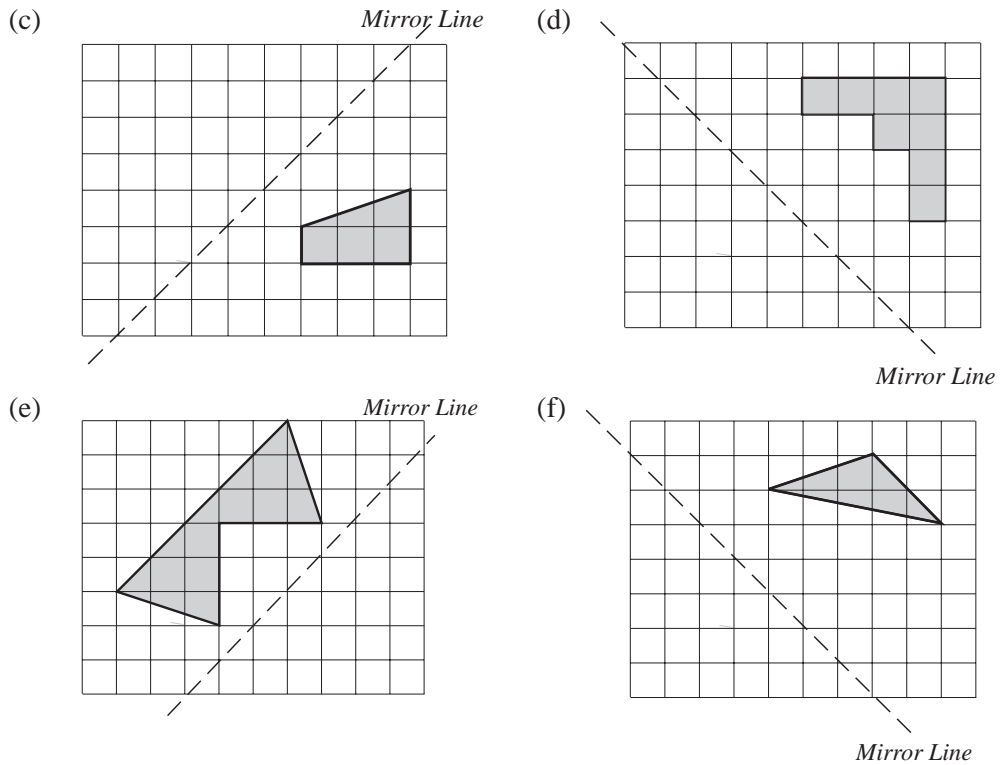

2. The diagram shows the positions of the shapes A, B, C, D and E.

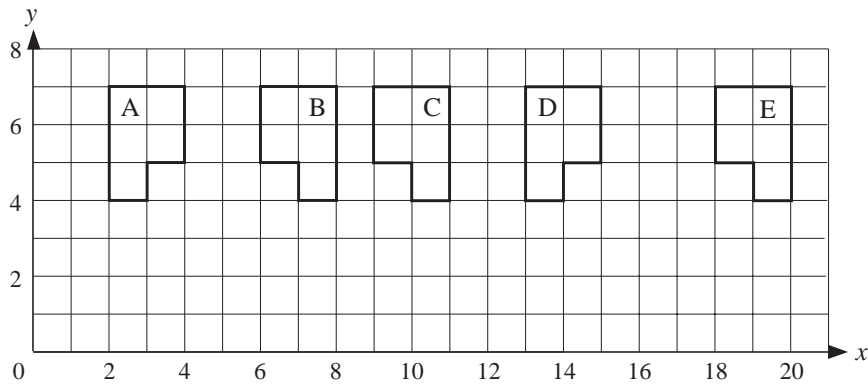

What is the equation of the line of reflection required to transform from:

- (a) A to B (b) B to D (c) D to C (d) C to A
- (e) A to E?

3. Copy the diagrams and reflect each of the shapes in the mirror lines given.

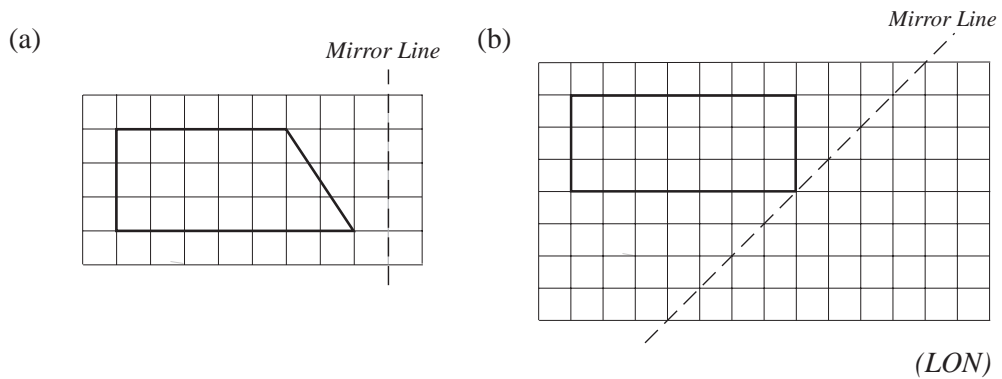

4. Copy the set of axes opposite and the shape labelled A.

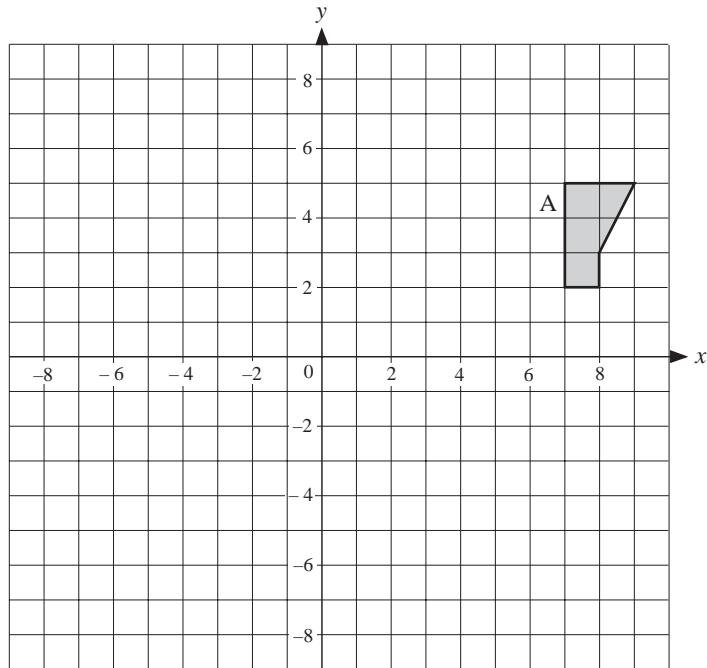

(a) Reflect A in the line $x = 5$ to obtain B.

(b) Reflect B in the line $y = -2$ to obtain C.

(c) Reflect C in the line $x = -3$ to obtain D.

(d) Reflect D in the line $y = -2$ to obtain E.

(e) Name two reflections of E which would bring the shape back to A.

5. The diagram shows a number of shapes, some of which have been reflected in various lines.

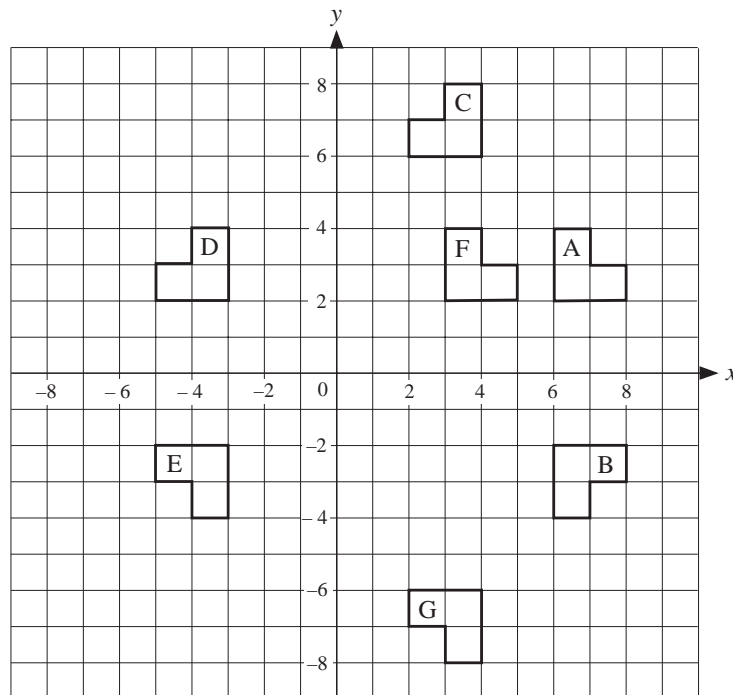

State whether each mapping is a reflection and if so, give the equation of the mirror line.

(a) A to B

(b) A to D

(c) A to C

(d) D to E

(e) E to F

(f) B to G

(g) C to G

(h) F to D

(i) B to E.

6.

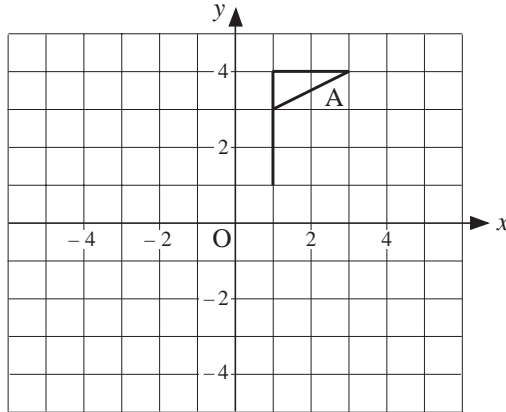

On a copy of the diagram:

- (a) reflect flag A in the line $y = x$. Label the image B.
- (b) enlarge flag A with scale factor $\frac{1}{2}$ and centre $(-3, 2)$. Label the image C.

(OCR)

7. Triangle A and triangle B have been drawn on the grid.

- (a) On a copy of the diagram, reflect triangle B in the line $y = 2$. Label this image C.
- (b) Describe fully the single transformation which will map triangle B onto triangle A.

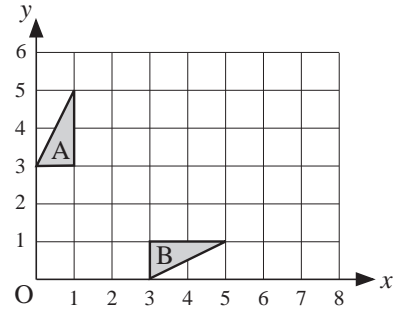

(Edexcel)

14.9 Rotations

- 1. Copy the axes and shape A shown.
 - (a) Rotate the shape A through 90° anticlockwise around $(0, 0)$ to obtain B.
 - (b) Rotate the shape A through 180° clockwise around $(0, 0)$ to obtain C.

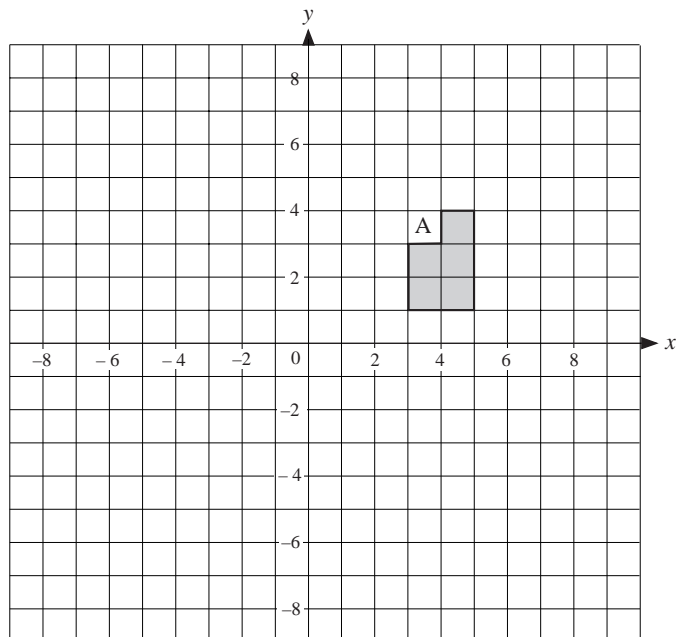

- (c) What rotation is needed to obtain the shape C from B?

2. Copy the axes and shape shown below.

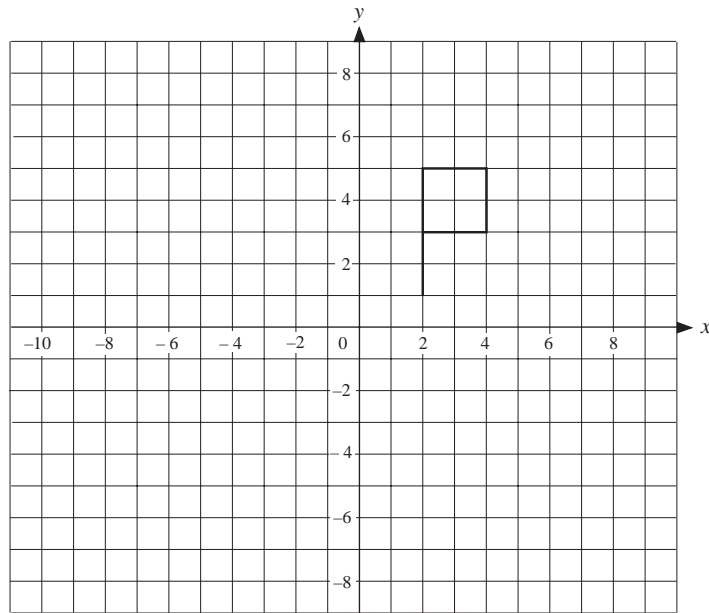

- Rotate the original shape through 90° clockwise about the point (1, 0).
 - Rotate the original shape through 180° about the point (5, 2).
 - Describe the rotation that takes the shape in (b) to the shape in (a).
 - Rotate the original shape through 90° anti-clockwise about the point $(-2, -1)$.
3. The diagram shows the position of a shape labelled A and other shapes which were obtained by rotating A.

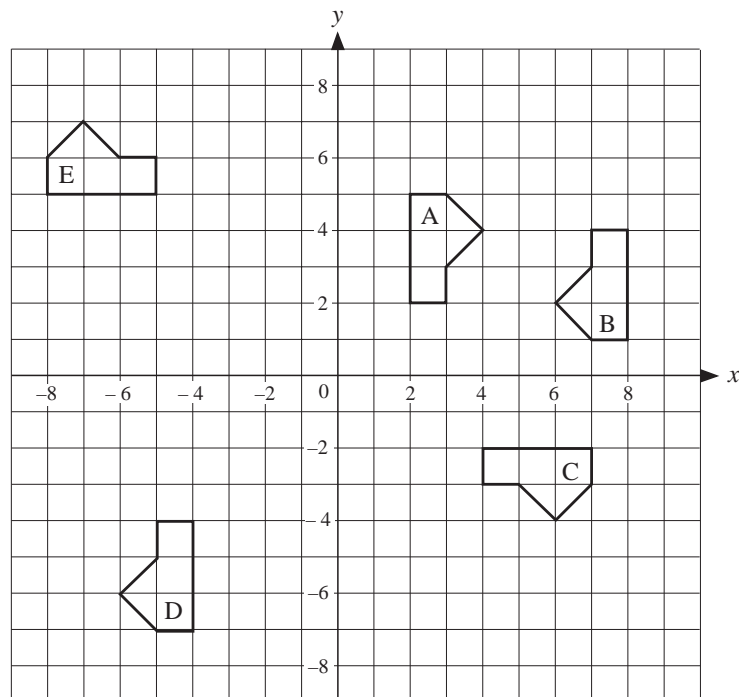

- Describe how each shape can be obtained from A by a rotation.
- Which shapes can be obtained by rotating the shape B?

4.

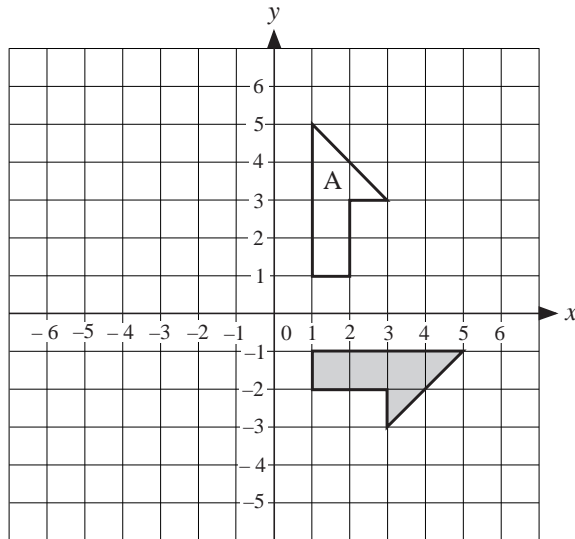

- (a) Describe fully the single transformation which will transform the shape labelled A to the shaded shape.
- (b) On a copy of the grid, draw the shaded shape after it has been reflected in the line $y = x$.

(NEAB)

5.

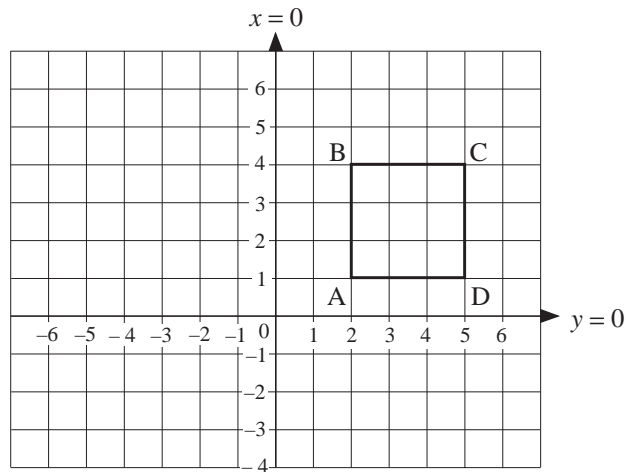

- (a) The square ABCD is reflected in the line $x = 1$. What are the new coordinates of C?
- (b) The square ABCD is rotated through 180° about A. What are the new coordinates of C?

(SEG)

- 6. (a) Copy the diagram below.

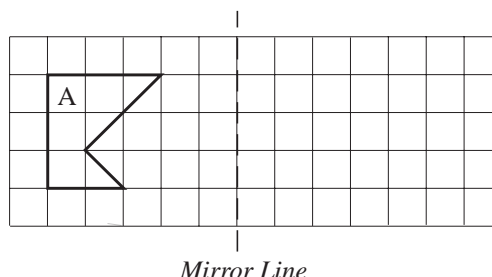

Reflect the shape A in the mirror line. Label the reflection B.

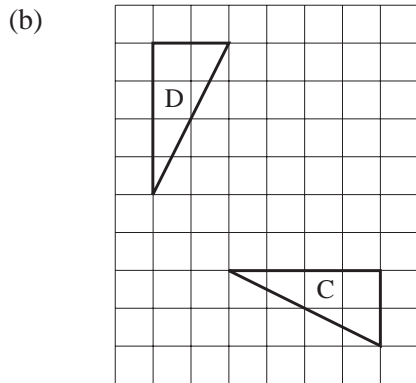

Describe fully the transformation which maps the triangle C onto the triangle D.

(LON)

7. The sketch shows the position of a rectangle ABCD.

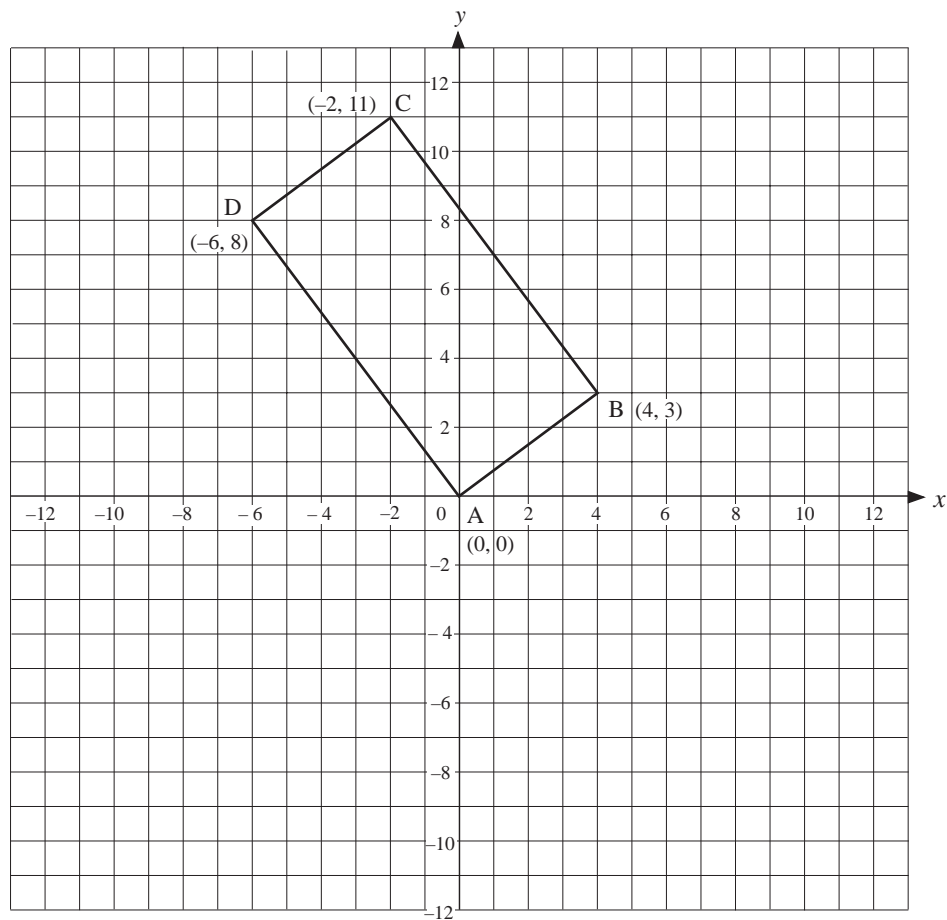

- (a) The rectangle ABCD is reflected in the line $x = 4$ to give rectangle $A_1B_1C_1D_1$. What are the coordinates of C_1 ?
- (b) The rectangle ABCD is rotated about A anticlockwise through 90° to give $A_2B_2C_2D_2$. What are the coordinates of B_2 ?
- (c) The rectangle ABCD is enlarged by scale factor 2, centre A. What are the coordinates of the new position of B?

(SEG)

8.

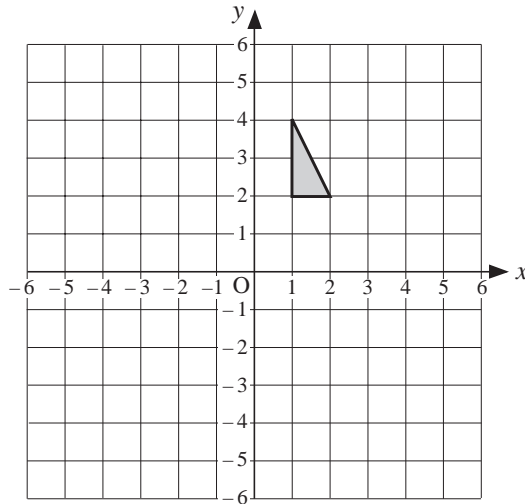

- (a) On a copy of the diagram, reflect the shaded triangle in the line $y = -x$. Label this new triangle with the letter A.
- (b) Rotate the original shaded triangle by a quarter-turn anticlockwise about $(0, 2)$. Label this new triangle with the letter B.

(OCR)

9.

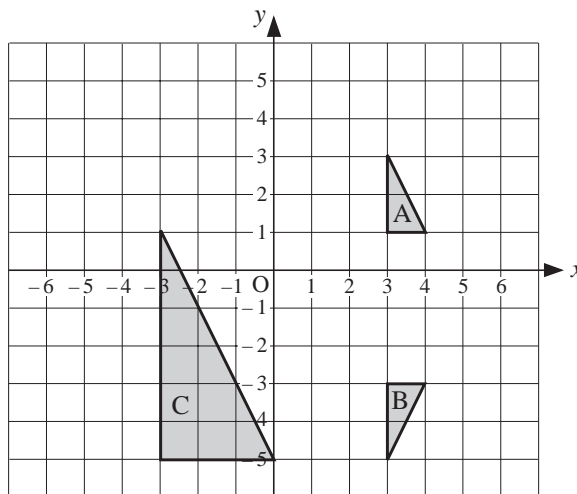

- (a) Describe the transformation that maps triangle A to triangle B.
- (b) Triangle A is rotated 90° anti-clockwise about $(0, -1)$. On a copy of the diagram, draw the image of A after this transformation.
- (c) Triangle C is an enlargement of triangle A.
 - (i) Write down the scale factor of the enlargement.
 - (ii) Write down the coordinates of the centre of the enlargement.

(AQA)

10. (a)

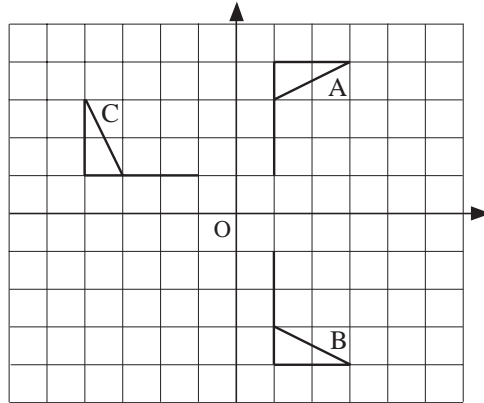

- (i) Describe fully the single transformation that maps flag A onto flag B.
- (ii) Describe fully the single transformation that maps flag A onto flag C.

(b) Calculate the area of this flag.

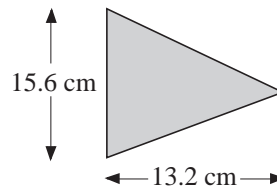

(OCR)

14.10 Translations

1. The shaded shape has been moved to each of the other positions by a translation. Give the vector used for each translation.

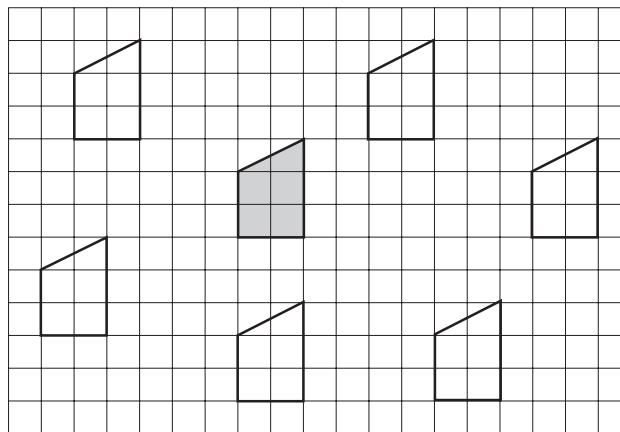

2. For the shapes shown, describe the translation which maps:

- (a) $A \rightarrow B$
- (b) $A \rightarrow C$
- (c) $B \rightarrow C$
- (d) $E \rightarrow A$
- (e) $E \rightarrow B$
- (f) $B \rightarrow A$.

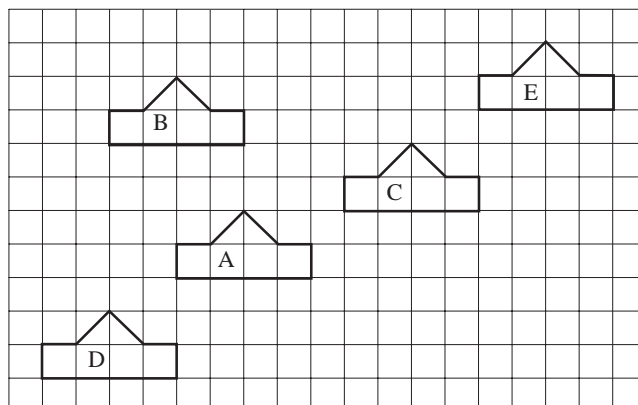

3.

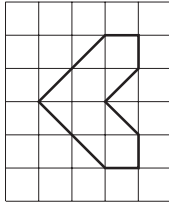

Copy this diagram. Draw the image of this shape when translated using:

- (a) $\begin{pmatrix} 5 \\ 0 \end{pmatrix}$ (b) $\begin{pmatrix} -3 \\ 3 \end{pmatrix}$ (c) $\begin{pmatrix} 7 \\ 2 \end{pmatrix}$.

4. Copy the shape opposite.

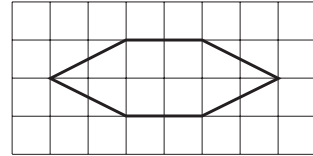

- (a) Translate the shape using the vector $\begin{pmatrix} 7 \\ 0 \end{pmatrix}$.
- (b) Translate the new shape using the vector $\begin{pmatrix} 0 \\ -3 \end{pmatrix}$.
- (c) What translation is needed to translate the original shape to the final shape?

5. The points A, B and C have coordinates (3, 2), (-2, 5) and (-3, -1) respectively. Find the vector needed to translate:

- (a) A to B (b) B to C (c) A to C.

6.

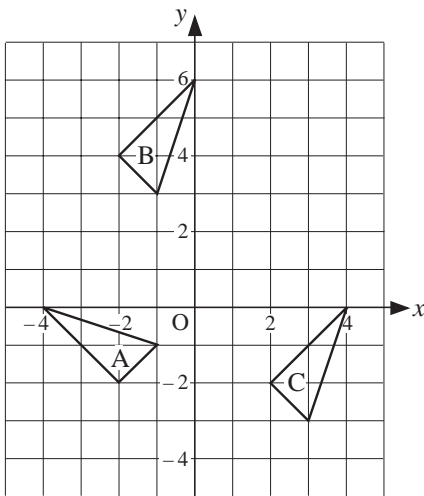

- (a) Find the centre of the rotation which maps triangle A on to triangle B.
- (b) Describe the single transformation which maps triangle B on to triangle C.

(OCR)

7. The diagram shows a shaded flag. On a copy of the diagram:

- (a) rotate the shaded flag 90° anti-clockwise about the origin. Label this new flag with the letter A.
- (b) translate the original shaded flag 2 units to the right and 3 units down. Label this new flag with the letter B.
- (c) reflect the original shaded flag in the line $y = 1$. Label this new flag with the letter C.

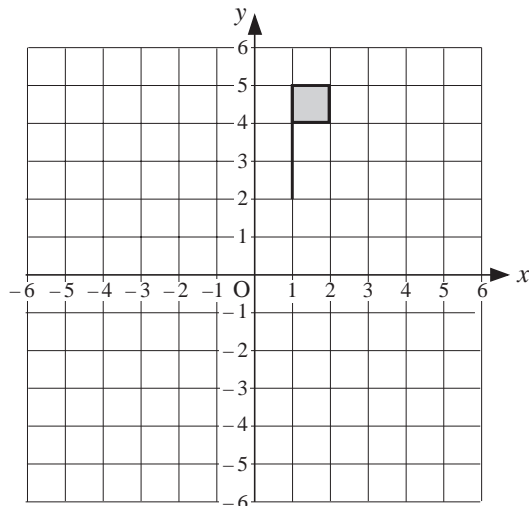

(AQA)

14.11 Combined Translations

1. Copy the set of axes and shape shown below.

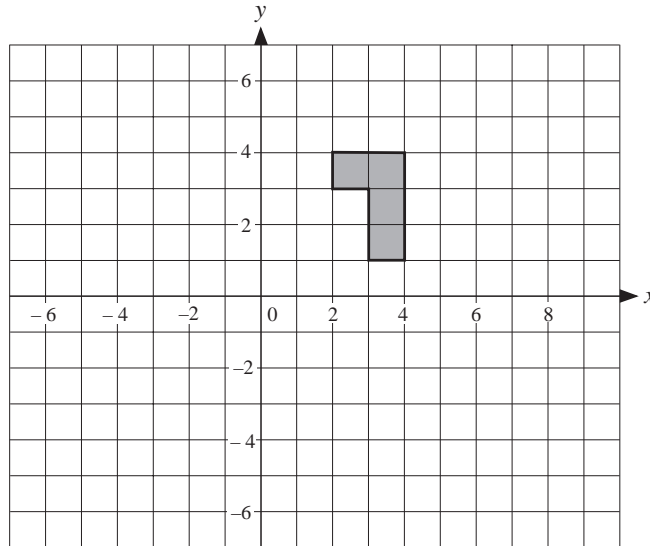

- Reflect this shape in the line $x = 5$.
 - Rotate the original shape 90° clockwise about $(5, 0)$.
 - Reflect the shape in (b) about the line $x = 2$.
 - Describe a single transformation of the shape in part (a) to the shape formed in part (c).
- 2.

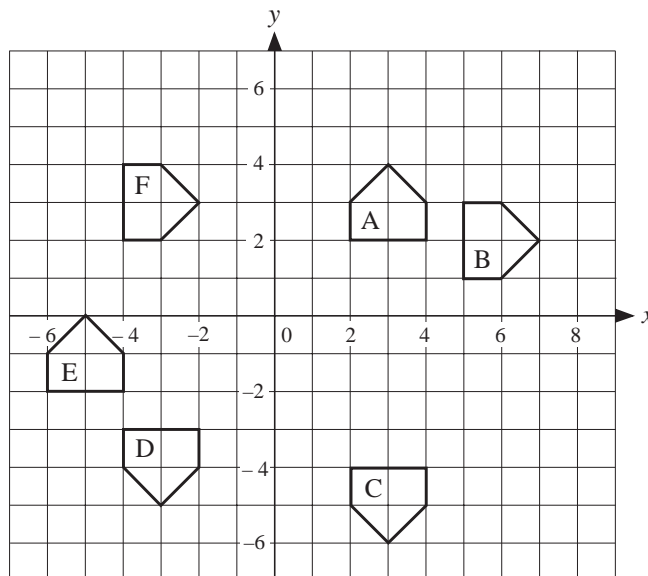

- Describe a single transformation from
 - A to B
 - F to B
 - A to D
 - E to A.
- Describe two combined transformations for
 - B to C
 - C to E
 - C to F.

3. (a) The point A is reflected in the y -axis.
The image is the point B.
Write down the coordinates of B.
- (b) The point A is rotated through 90°
anticlockwise about O.
The image is the point C.
Write down the coordinates of C.
- (c) The point B can be mapped onto
point C by a translation.
Write down the column vector of
this translation.

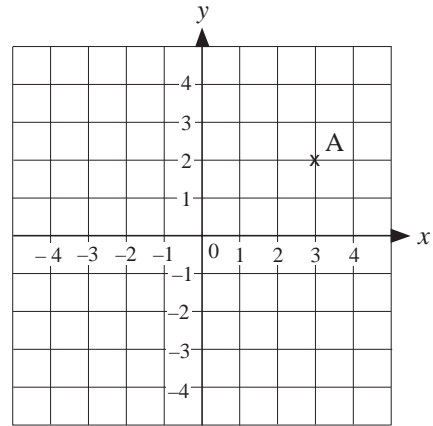

(MEG)

4.

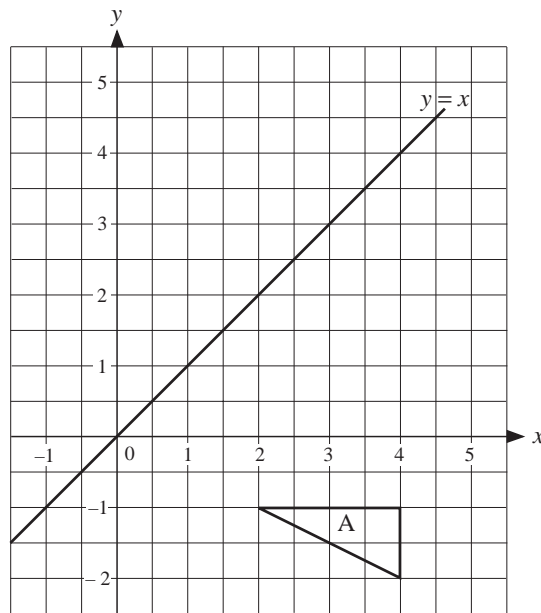

- (a) Copy the diagram and reflect the triangle A in the x -axis. Label the reflection B.
- (b) Reflect the triangle B in the line $y = x$. Label the reflection C.
- (c) Describe fully the single transformation which maps triangle A onto triangle C.
- (d) Write down the equation of the line which is parallel to $y = x$ and which passes through the point (0, 8).

This line crosses the x -axis at the point P.

- (e) Calculate the coordinates of P.

(LON)

5. The parallelogram ABCD has vertices at (6, 3), (9, 3), (12, 9) and (9, 9) respectively.

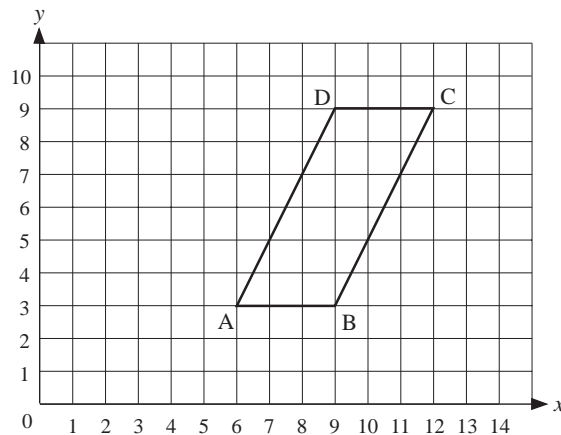

- (a) An enlargement, scale factor $\frac{1}{3}$ and centre (0, 0), transforms parallelogram ABCD onto $A_1B_1C_1D_1$. Copy the diagram and draw the parallelogram $A_1B_1C_1D_1$.
- (b) The parallelogram $A_1B_1C_1D_1$ is translated by the vector $\begin{pmatrix} 0 \\ 2 \end{pmatrix}$ onto $A_2B_2C_2D_2$. What are the coordinates of C_2 ?
- (c) The parallelogram $A_2B_2C_2D_2$ can be transformed onto ABCD by an enlargement. Give the scale factor and centre of this enlargement.

(SEG)

6. The diagram shows triangles T, S and U.
- S is the image of T under a reflection in the line $x = 3$.
- U is the image of S under reflection in the line $x = 6$.
- A reflection in the line $x = 3n$, where n is an integer, is denoted by R_n ,

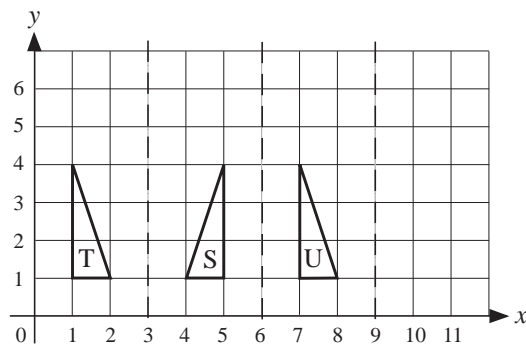

So S is the image of T under R_1 and U is the image of T under R_1 followed by R_2 . V is the image of T under the successive transformations R_1 followed by R_2 followed by R_3 .

- (a) Draw V on a copy of the diagram above.
- (b) Describe fully the single transformation that will map T to V.

W is the image of T under the successive transformation R_1 , followed by R_2 , followed by R_3 and so on to R_n .

- (c) Describe fully the single transformation that will map T to W:
- (i) when n is even (ii) when n is odd.

(LON)

14.12 Congruence

1.

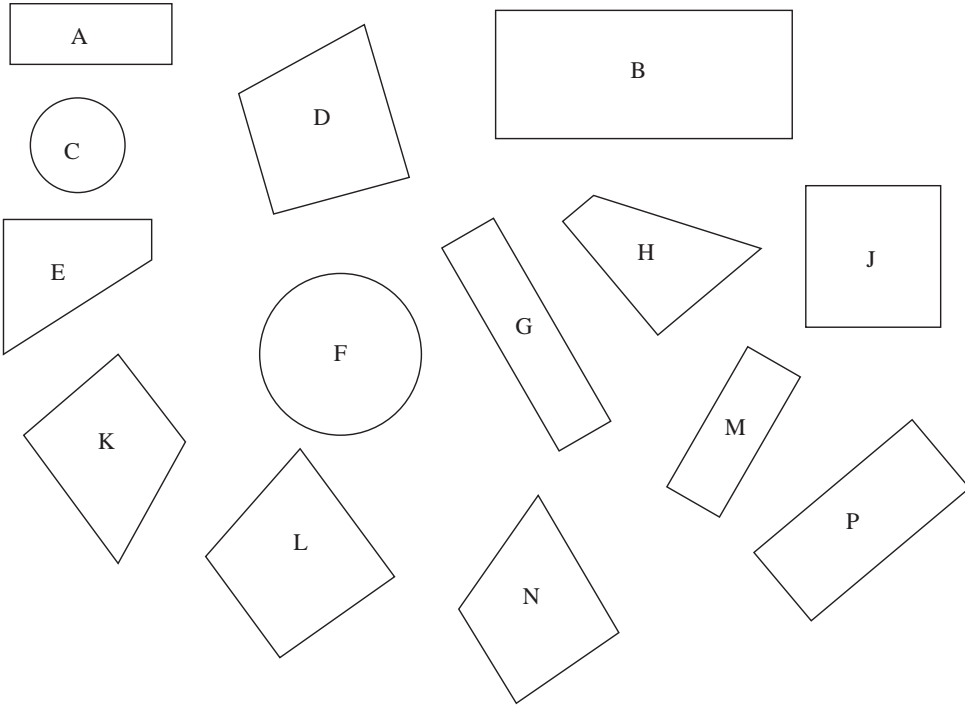

From the shapes in the diagram, write down the letters of three pairs of congruent shapes.

(LON)

2. State which pairs of triangles are congruent.

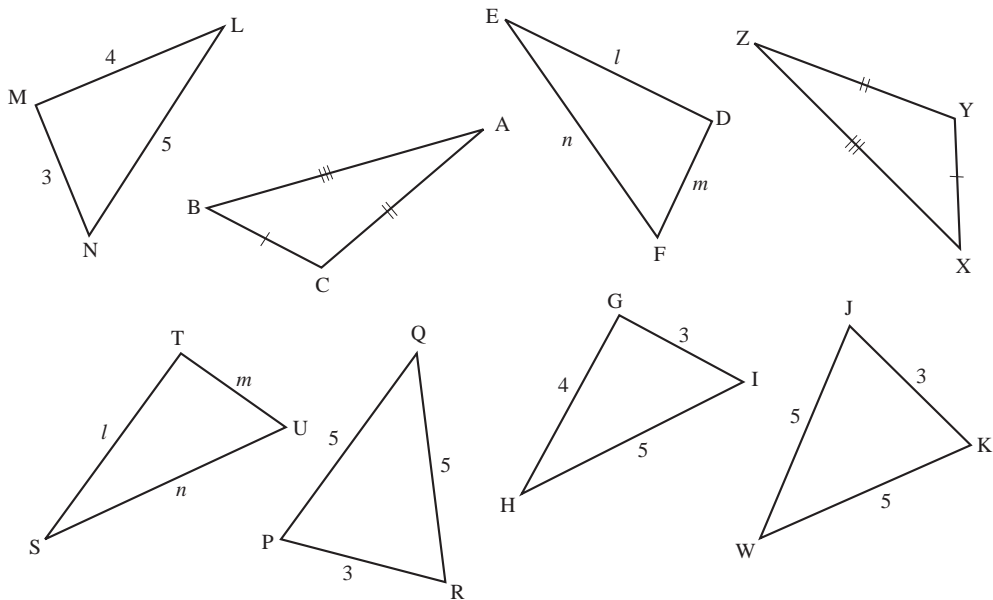

3. For each question below, determine whether the triangles are congruent. If the triangles *are* congruent, justify your answer.

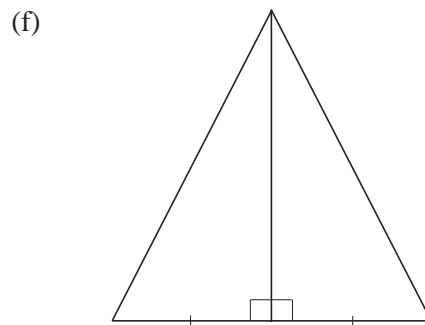
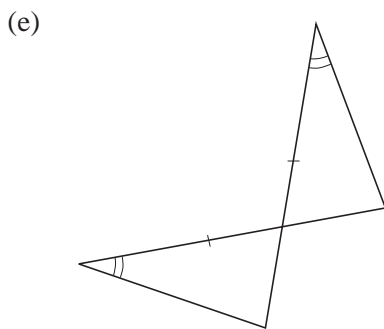
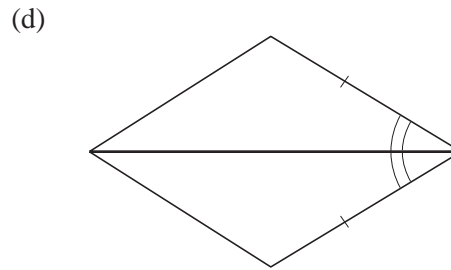
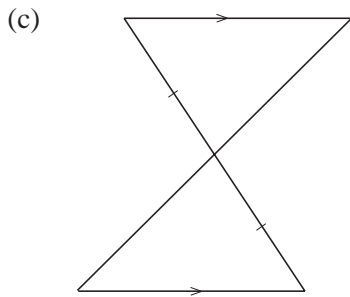
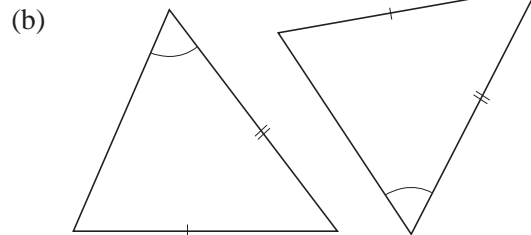
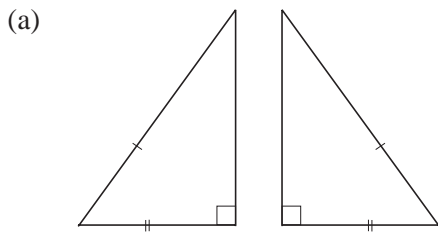

4. Pythagoras wrote about a triangle where

$$AB = 1 \text{ unit,}$$

$$BC = 1 \text{ unit, and}$$

$$\hat{A}BC = 90^\circ.$$

- (a) Pythagoras claimed that the length of AC is a rational number.

Was he correct? Explain your answer.

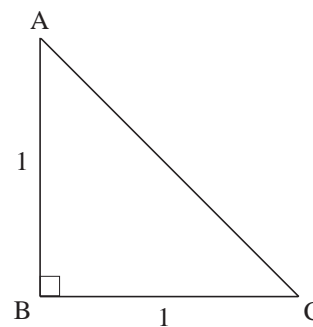

- (b) The triangle PQR has $PQ = 1$ unit, $QR = \sqrt{3}$ units and $\hat{Q}PR = 90^\circ$, as shown.

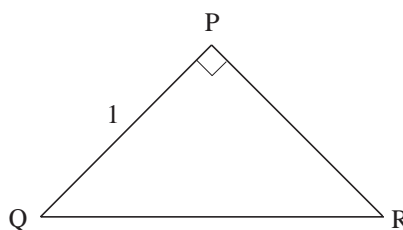

Is the triangle PQR congruent to triangle ABC? Explain your answer.

(SEG)

5. (a) Here are six L-shapes on a unit square grid.

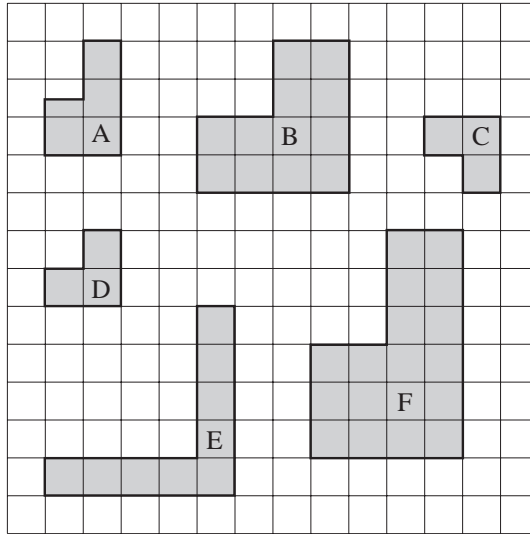

- (i) Which two L-shapes are congruent?
 (i) Which L-shape is an enlargement of A?

- (b) Here is a different L-shape.

Show on a copy of the grid opposite how four of these L-shapes can be fitted together to make a square.

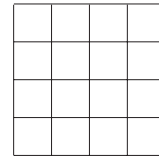

- (c) On a copy of the grid below, draw the L-shape after a rotation of 180° .

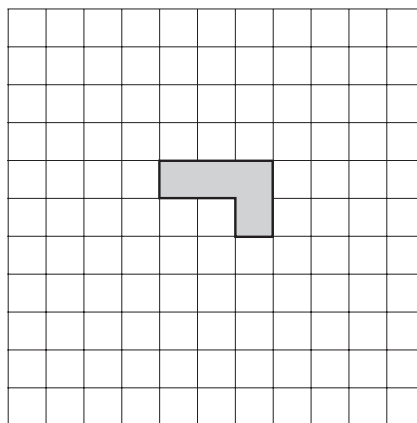

(AQA)

14.13 Similarity

1. The diagram shows two similar triangles.

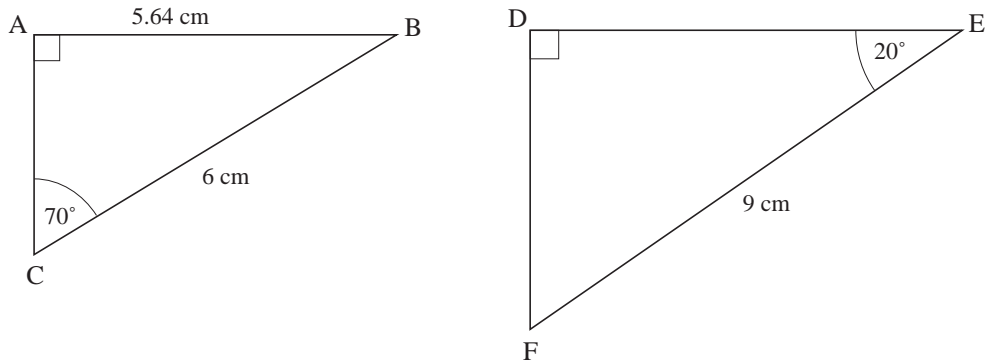

What is:

- (a) the size of angle DFE (b) the length of DE
 (c) the ratio $AC : DF$?
2. A cylinder has a height of 10 cm and has volume 300 cm^3 . Find the volumes of similar cylinders of heights:
- (a) 5 cm (b) 20 cm.
3. Two cubes have volumes 729 cm^3 and 1331 cm^3 . What is the ratio of:
- (a) the side length of the cubes
 (b) the surface areas of the cubes?

4. In the diagram, $CD = 4$ metres,
 $CE = 3$ metres and $BC = 5$ metres.

AB is parallel to DE .

ACE and BCD are straight lines.

- (a) Explain why triangle ABC is similar to triangle EDC .
 (b) Calculate the length of AC .

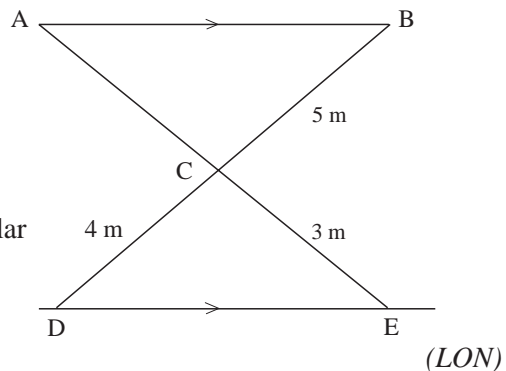

5. (a) Show clearly that these two triangles are similar.
 (b) Calculate the value of x .

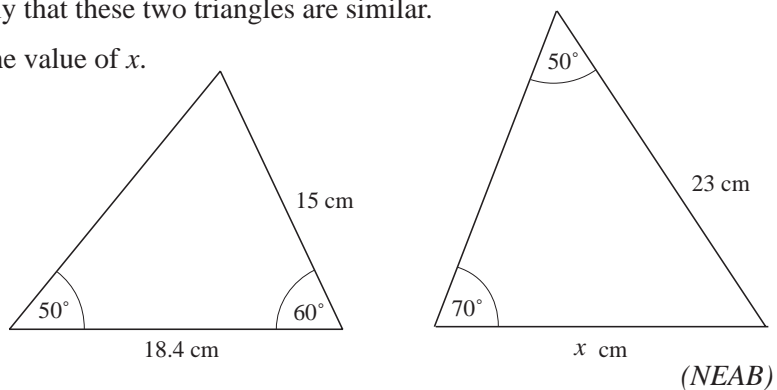

6. All these triangles are similar.

- (a) Calculate the length x .
- (b) Calculate the length y .

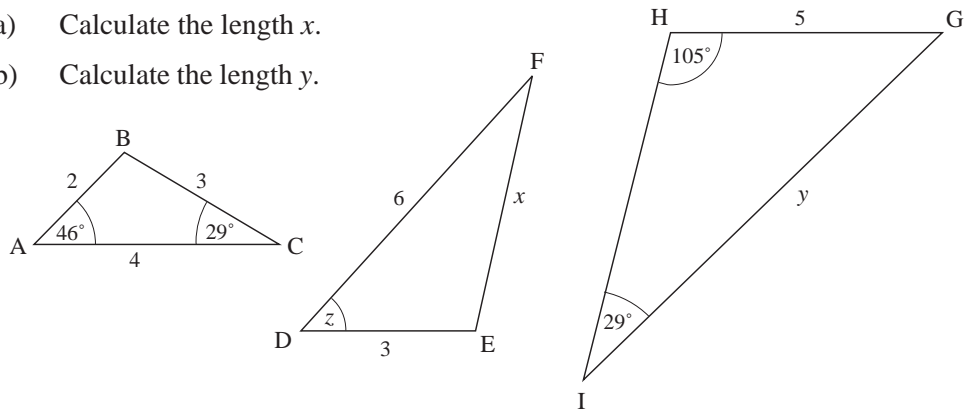

(SEG)

7.

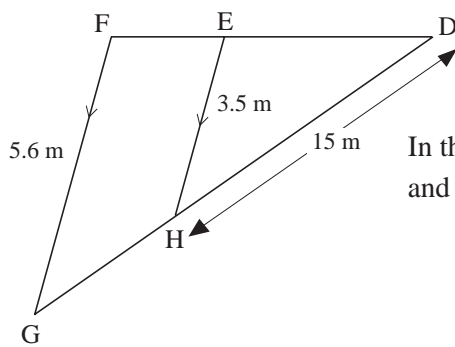

In the diagram, $FG = 5.6$ metres, $EH = 3.5$ metres and $DH = 15$ metres. EH is parallel to FG .

8.

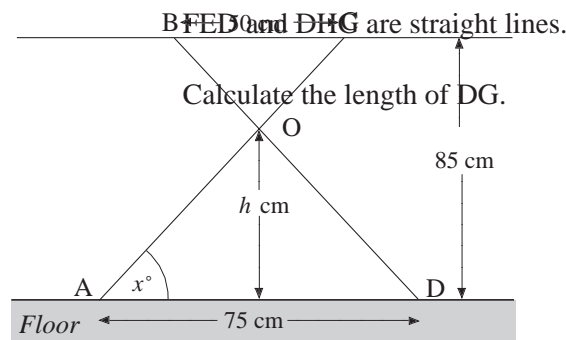

(LON)

The diagram shows a simplified ironing board. The feet, A and D, are 75 cm apart. The supports at B and C are 50 cm apart. The legs, AC and BD, are equal in length and are pivoted at O. BC is parallel to AD.

The height of the ironing board above the floor is 85 cm.

- (a) Use similar triangles to calculate the height, h cm, of O above the floor.

9. The diagram shows a symmetrical framework for a bridge.

$$AC = 100 \text{ m}$$

$$AB = BC = 70 \text{ m}$$

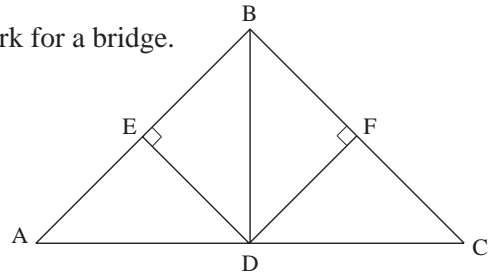

- (a) (i) Calculate the angle BAD.
 (ii) Calculate the length ED.

A similar framework is made with the length corresponding to $AC = 180 \text{ m}$.

- (b) (i) Calculate the length corresponding to AB.
 (ii) What is the size of the angle corresponding to angle BAD?

(SEG)

10. (a) The model of the cross-section of a roof is illustrated below.

$$BC = 6 \text{ cm}$$

$$CD = 9 \text{ cm}$$

$$\hat{CDE} = 19.5^\circ$$

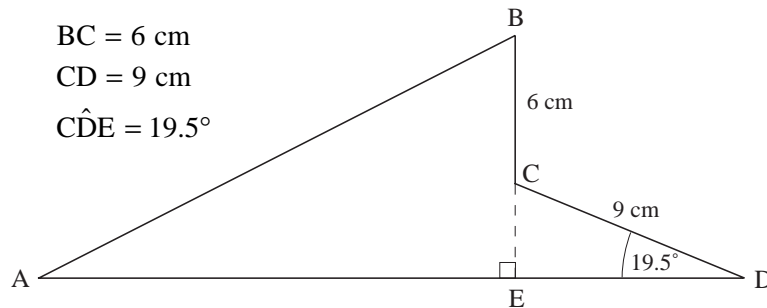

- (i) Calculate the length of CE.
 (ii) Triangles ABE and DCE are similar triangles with angle BAE equal to angle CDE. Calculate the length of AB.

- (b) When the roof is constructed, the actual length of BC is 4.5 m. Calculate the area of the cross-section of the actual roof space.

(SEG)

11. (a) Paul's ladder is 4 m long.

- (i) Paul leans his ladder against a vertical wall, with the end, A, on horizontal ground.

The angle between the ladder and the ground is 70° .

Calculate the distance of A from the wall.

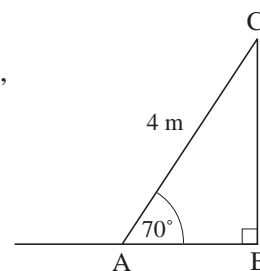

- (ii) Pamela moves the ladder and uses it to reach a windowsill which is 3.8 m above the ground.

For safety, the angle between the ladder and the ground should be within 2° of 70° .

Is the ladder safely placed?

(You must show some calculation to explain your answer.)

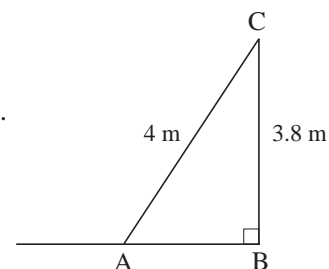

- (b) Ranjit has a stepladder.

P is the midpoint of RS. Q is the midpoint of TS.
The length of PQ is 60 cm.

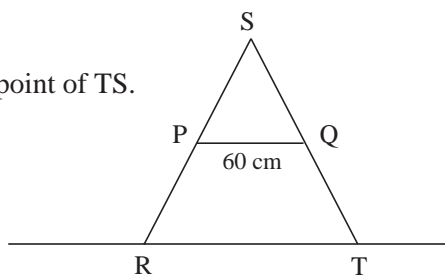

- (i) Explain why triangles SPQ and SRT are similar.
(ii) Calculate the length of RT.

(SEG)

12.

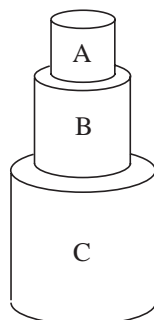

A child builds a tower from three similar cylindrical blocks.
The smallest block, A, has radius 2.5 cm and height 6 cm.

- (a) Find the volume of the smallest block.
(b) Block B is an enlargement of A and block C is an enlargement of B, each with a scale factor of $1\frac{3}{4}$.
Find the total height of the tower.

(MEG)

13. Two similar solid shapes are made. The height of the smaller shape is 7 cm.
The width of the smaller shape is 6 cm. The width of the larger shape is 9.6 cm.

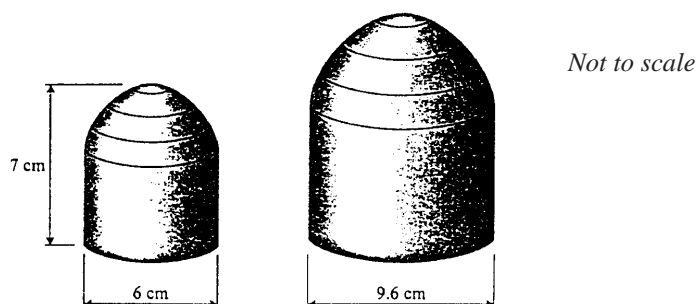

- (a) Calculate the height of the larger shape.
(b) The volume of the larger shape is 695 cm^3 . Find the volume of the smaller shape. (SEG)

14.

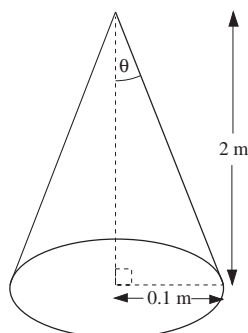

This is a scale model of the proposed Millennium Tower.
The model is a cone of height 2 m and base radius 0.1 m.
The angle between the slanting side and the vertical is θ .

- (a) What is the value of θ , to the nearest degree?
(b) The proposed Millennium Tower is 1000 m high.
What is its base radius?
(c) Calculate, in cubic metres, the volume of the model.
(d) How many times larger than the scale model is the volume of the proposed Millennium Tower?

(SEG)

15. ABC and PQR are similar triangles.

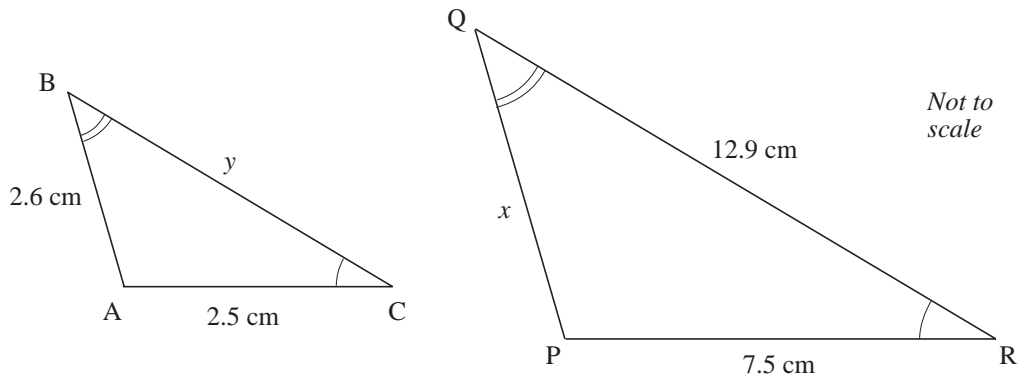

- (a) Find the length marked
- x
 - y
- (b) (Area of triangle PQR) = $n \times$ (Area of triangle ABC)
Find the value of n .

(OCR)

14.14 Enlargements with Negative Scale Factors

1. The diagram below shows the original shape (shaded) and the images obtained by enlargements with different scale factors.
State the scale factor for each enlargement.

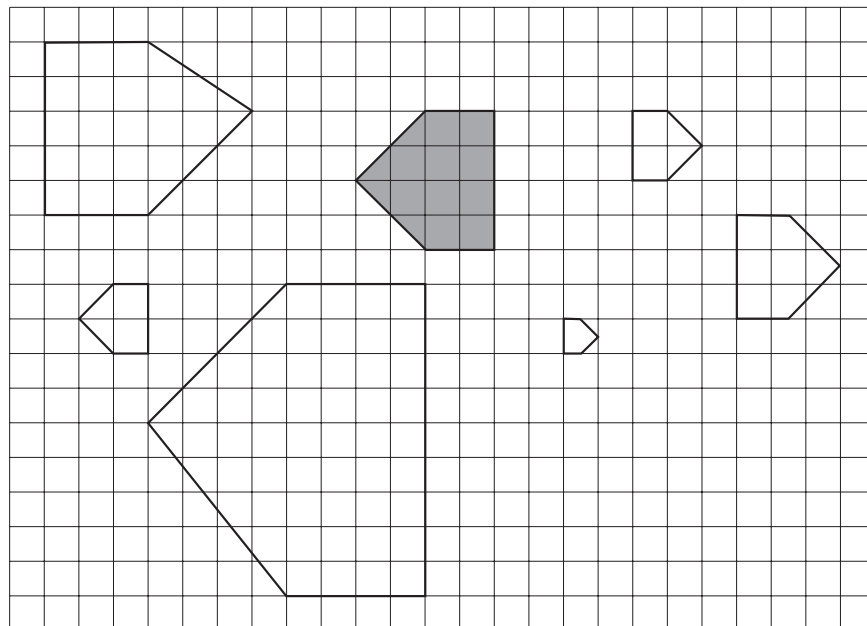

2. The shaded shape has been enlarged to give the other images. For each image, find the scale factor and the coordinates of the centre of enlargement.

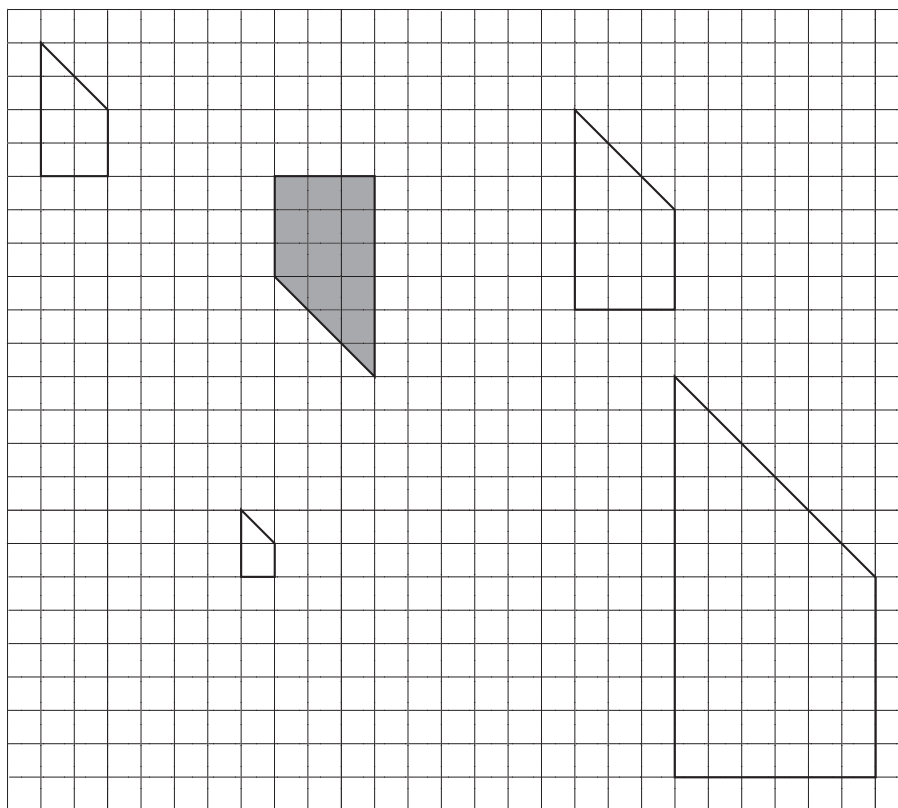

3. Copy each diagram below. Enlarge each shape using the scale factor and centre of enlargement given.

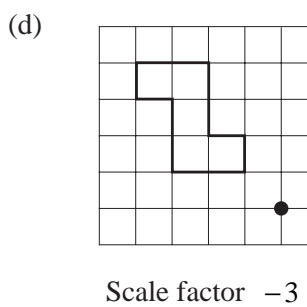
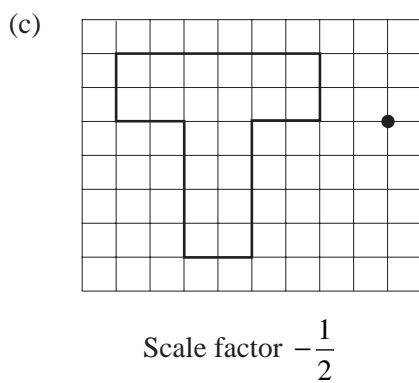
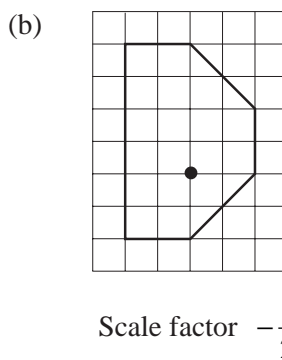
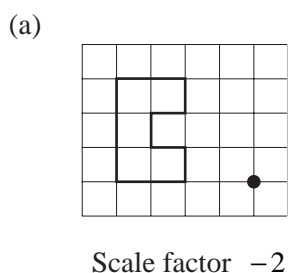

4. Copy the axes and shape shown below.

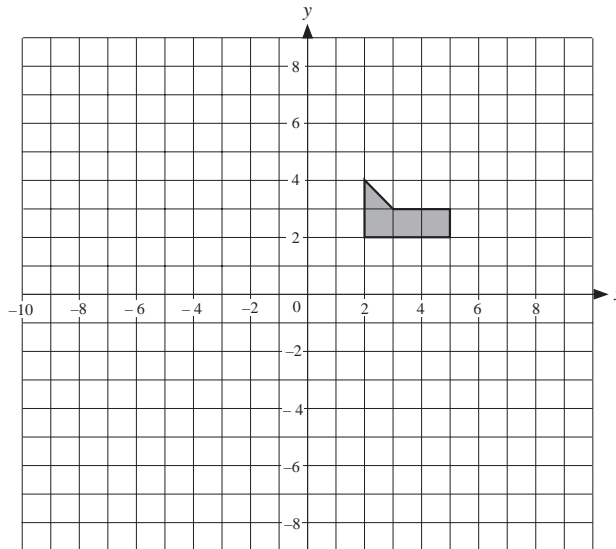

Draw the image obtained when the original shape is enlarged with:

- (a) scale factor -2 , centre of enlargement $(0, 0)$
 - (b) scale factor -1 , centre of enlargement $(0, 2)$
 - (c) scale factor -2 , centre of enlargement $(4, 0)$.
5. Triangle P is mapped to triangle Q by an enlargement of scale factor -0.4 .

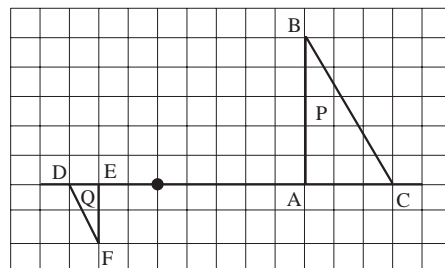

If BC is of length 5 cm, what is the length of DF?