

4 VECTORS 2

Objectives

After studying this chapter you should

- be able to integrate acceleration vectors to obtain velocity and position vectors;
- be able to understand the consequences of modelling force as a vector in equilibrium and non-equilibrium situations;
- be able to resolve forces into perpendicular components;
- be able to apply the law of friction in its simplest form;
- be able to appreciate and use Newton's Second Law.

4.1 From acceleration to velocity to position vector

In the last chapter you used differentiation to derive the velocity vector \mathbf{v} and acceleration vector \mathbf{a} from a given position (i.e. displacement) vector \mathbf{r} . Suppose, instead, that you are given the acceleration \mathbf{a} of an object moving in a plane, for example

$$\mathbf{a} = 2\mathbf{i} + 3t\mathbf{j}.$$

This means

$$\frac{d^2\mathbf{r}}{dt^2} = 2\mathbf{i} + 3t\mathbf{j}.$$

Integrating with respect to t gives

$$\frac{d\mathbf{r}}{dt} = (2t + A)\mathbf{i} + \left(\frac{3t^2}{2} + B\right)\mathbf{j}$$

where A and B are some constants. In order to determine the velocity vector precisely, more information is needed: for instance, the velocity at a particular time, say

$$\mathbf{v} = 3\mathbf{i} + \frac{1}{2}\mathbf{j} \text{ when } t = 1.$$

Then
$$3\mathbf{i} + \frac{1}{2}\mathbf{j} = (2 \times 1 + A)\mathbf{i} + \left(\frac{3}{2} \times 1^2 + B\right)\mathbf{j} .$$

Equating components gives

$$3 = 2 + A, \quad \frac{1}{2} = \frac{3}{2} + B$$

so that $A = 1$ and $B = -1$. Then

$$\mathbf{v} = (2t + 1)\mathbf{i} + \left(\frac{3}{2}t^2 - 1\right)\mathbf{j}.$$

Integrating again

$$\mathbf{r} = (t^2 + t + C)\mathbf{i} + \left(\frac{1}{2}t^3 - t + D\right)\mathbf{j}$$

for some constants C and D .

Again, specific information is needed in order to identify C and D . Suppose that, when $t = 1$, $\mathbf{r} = \mathbf{0}$ (i.e. the object is at the origin).

$$\text{Then } 0\mathbf{i} + 0\mathbf{j} = (1 + 1 + C)\mathbf{i} + \left(\frac{1}{2} - 1 + D\right)\mathbf{j}.$$

$$\text{Equating components gives } 0 = 2 + C, \quad 0 = -\frac{1}{2} + D$$

$$\text{so that } C = -2 \quad \text{and} \quad D = \frac{1}{2}.$$

$$\text{Then } \mathbf{r} = (t^2 + t - 2)\mathbf{i} + \left(\frac{1}{2}t^3 - t + \frac{1}{2}\right)\mathbf{j}.$$

In general,

$$\boxed{\mathbf{r} = x\mathbf{i} + y\mathbf{j}} \begin{array}{l} \text{differentiate} \rightarrow \\ \leftarrow \text{integrate} \end{array} \boxed{\frac{d\mathbf{r}}{dt} = \frac{dx}{dt}\mathbf{i} + \frac{dy}{dt}\mathbf{j}} \begin{array}{l} \text{differentiate} \rightarrow \\ \leftarrow \text{integrate} \end{array} \boxed{\frac{d^2\mathbf{r}}{dt^2} = \frac{d^2x}{dt^2}\mathbf{i} + \frac{d^2y}{dt^2}\mathbf{j}}$$

The values of the velocity and displacement at the start of the motion, i.e. at time $t = 0$, are needed to determine the constants which arise in the integration and are called the **initial conditions**.

Example

A particle starts from the origin with velocity $2\mathbf{i} + \mathbf{j}$, and is subject to an acceleration of $\mathbf{i} - 3\mathbf{j}$. Find the velocity and position vectors of the particle after t seconds, expressed as functions of t .

Solution

Integrating the acceleration

$$\mathbf{a} = \mathbf{i} - 3\mathbf{j}$$

gives the velocity

$$\mathbf{v} = (t + A)\mathbf{i} + (-3t + B)\mathbf{j},$$

where A and B are some constants.

When $t = 0$, $\mathbf{v} = 2\mathbf{i} + \mathbf{j}$

$$\text{so } 2\mathbf{i} + \mathbf{j} = (0 + A)\mathbf{i} + (0 + B)\mathbf{j}$$

and equating components gives $A = 2$, $B = 1$

so $\mathbf{v} = (t + 2)\mathbf{i} + (1 - 3t)\mathbf{j}$ is the velocity vector.

Integrating the velocity gives the position vector

$$\mathbf{r} = \left(\frac{t^2}{2} + 2t + C\right)\mathbf{i} + \left(t - \frac{3}{2}t^2 + D\right)\mathbf{j}$$

where C and D are constants.

When $t = 0$, $\mathbf{r} = \mathbf{0}$

$$\text{so } \mathbf{0} = (0 + 0 + C)\mathbf{i} + (0 + 0 + D)\mathbf{j}$$

and equating components gives

$$C = D = 0.$$

$$\text{Thus } \mathbf{r} = \left(\frac{t^2}{2} + 2t\right)\mathbf{i} + \left(t - \frac{3t^2}{2}\right)\mathbf{j}$$

is the position vector.

Example

A particle starts moving from the point $2\mathbf{i}$ with initial velocity $3\mathbf{i} - \mathbf{k}$ under an acceleration of $6t\mathbf{j}$ at time t seconds after the motion begins. Find the velocity and position vectors of the particle as functions of time.

Solution

Notice here that you are now working in three dimensions; however, the same rules apply.

$$\mathbf{a} = 6t\mathbf{j}$$

Integrating gives

$$\mathbf{v} = A\mathbf{i} + (3t^2 + B)\mathbf{j} + C\mathbf{k}.$$

When $t = 0$, $\mathbf{v} = 3\mathbf{i} - \mathbf{k}$

so $3\mathbf{i} - \mathbf{k} = A\mathbf{i} + (0 + B)\mathbf{j} + C\mathbf{k}.$

Equating components gives

$$A = 3, B = 0, C = -1.$$

Then $\mathbf{v} = 3\mathbf{i} + 3t^2\mathbf{j} - \mathbf{k}$ is the velocity vector.

Integrating again

$$\mathbf{r} = (3t + D)\mathbf{i} + (t^3 + E)\mathbf{j} + (-t + F)\mathbf{k}.$$

When $t = 0$, $\mathbf{r} = 2\mathbf{i}$

so $2\mathbf{i} = (0 + D)\mathbf{i} + (0 + E)\mathbf{j} + (0 + F)\mathbf{k}.$

Equating components gives

$$D = 2, E = F = 0.$$

Then $\mathbf{r} = (3t + 2)\mathbf{i} + t^3\mathbf{j} - t\mathbf{k}$ is the position vector.

Exercise 4A

- Given the position vector of a particle, find its velocity and acceleration vectors as functions of time t :
 - $\mathbf{r} = 2t\mathbf{i} + (3 - 5t^3)\mathbf{j}$
 - $\mathbf{r} = \mathbf{i} - 3t\mathbf{k}$
 - $\mathbf{r} = \frac{1}{t^2}\mathbf{i} + 4t\mathbf{j} + \frac{1}{2}t^2\mathbf{k}$
- Given the acceleration vector $\mathbf{a} = -0.2\mathbf{j}$ of an object, with initial velocity $0.5\mathbf{i}$, and that the object starts at the origin, find its velocity and position vectors at any time t .
- A particle P is moving such that at time t seconds it has position vector

$$\mathbf{r} = -t\mathbf{i} + 8t^2\mathbf{j} + (1 + t - t^2)\mathbf{k} \text{ metres.}$$

Show that P has a constant acceleration, stating its magnitude. Find also the speed of P when $t = 5$ s.
- In each case (a) to (c), find the velocity and position vectors, given the acceleration vector of a particle and the initial conditions.
 - $\mathbf{a} = 5\mathbf{i} - t\mathbf{k}$; when $t = 0$, $\mathbf{v} = 2\mathbf{i} + \mathbf{j}$ and $\mathbf{r} = 3\mathbf{i} - \mathbf{j} + 7\mathbf{k}$
 - $\mathbf{a} = 4\sqrt{t}\mathbf{j} - \frac{1}{2}t^2\mathbf{k}$; when $t = 0$, $\mathbf{v} = \frac{1}{3}\mathbf{j}$, $\mathbf{r} = -\mathbf{i} + \frac{5}{3}\mathbf{j} - \mathbf{k}$
 - $\mathbf{a} = -10\mathbf{j}$; when $t = 0$, $\mathbf{v} = 3\mathbf{i} + 2\mathbf{j}$, $\mathbf{r} = \mathbf{0}$
- For Question 4, parts (a) and (b), find the speed of the particle when $t = 2$ and the distance of the particle from the origin at this time.

4.2 Force as a vector

Up until now you have seen the vectorial nature of displacement, velocity and acceleration. However, the principal application of vector properties will be in the modelling of forces.

Activity 1 Identifying forces

Identify as many situations as you can, that you could expect to find in and around the home, where several forces are acting on an object.

In each case, try to specify the natures of the various forces involved; where possible give a brief qualitative analysis of these forces.

Here are some further examples for you to consider.

1. The top of a telegraph pole

The 'pulling' forces in each wire (tensions) are most probably of different strengths, hence labelled differently here.

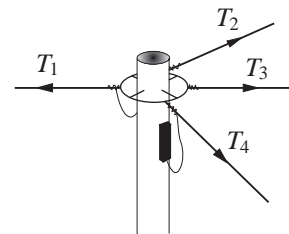

2. The hanger of a peg-bag on a clothes line

Here, each portion of the line exerts a tension on the hanger. Note that they are labelled the same since you might reasonably expect the tension to be the same throughout the entire length of the line. There is also the weight of the pegs, bag, and the hanger itself, pulling the hanger downwards. (These have all been combined into the single weight W).

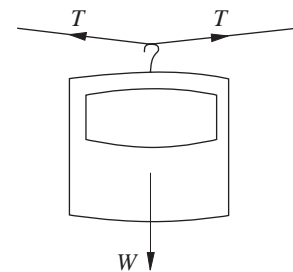

3. The seat of a garden-swing with a child on it

The tensions in the four portions of chain are labelled the same since, if the child sits centrally, you can expect these to be equal.

W = weight of child

w = weight of seat

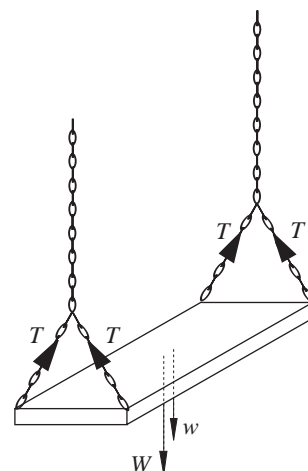

4. A vacuum cleaner 'hoovering' the carpet

P is a pushing force applied to the cleaner via the handle, of variable magnitude and changing direction from time to time, N is the normal contact force of the floor on the vacuum cleaner, W is its weight, R resistances to motion, including friction.

If forces are vectors, then they need to satisfy the parallelogram law.

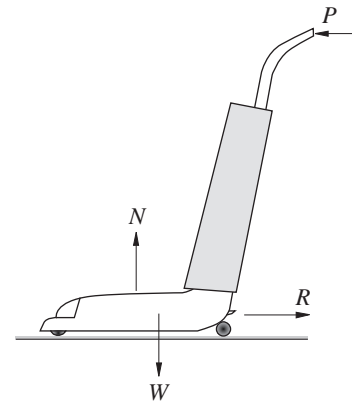

Activity 2 Three-force experiment

You will need a simple kit including two pulleys, some string, weights and a sheet of paper for this activity.

Set the pulley system up as shown in the diagram:

W_1 , W_2 and W_3 are (different) small weights attached to the string so that the system is at rest.

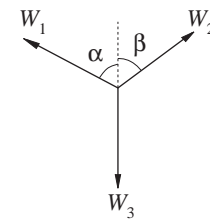
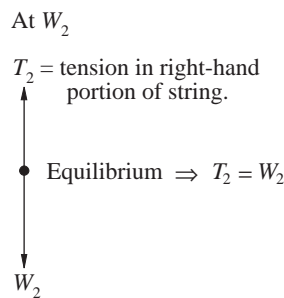
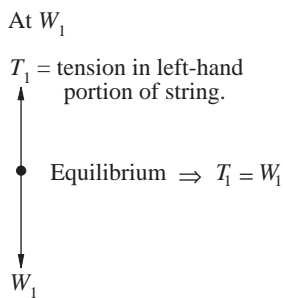
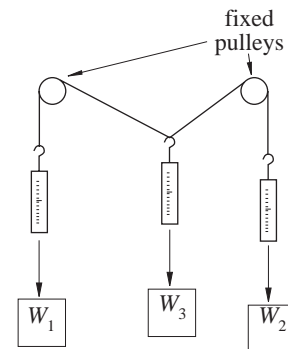

At the point of application of the three forces involved, the forces are shown in the diagram opposite.

Choose different values for the weights W_1 , W_2 and W_3 to hang on the system at the three points, and measure the angles α and β as accurately as you can. For each set of values, verify the following result by means of a scale-drawing:

e.g.	W_1	α	W_2	β	W_3
	20	46.5°	30	29°	40

The resultant of the vectors W_1 and W_2 , denoted by \mathbf{R} , can be found by the **parallelogram rule**, and measurement of the scale-drawing shows that \mathbf{R} has the same magnitude as the vector W_3 , but opposite direction; which is to be expected if the point of application is in equilibrium.

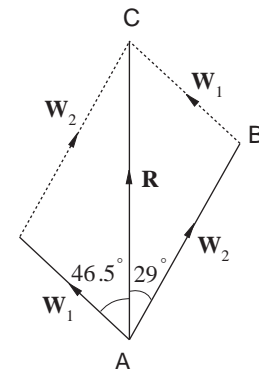

Did you find any sets of weights which would not remain in equilibrium? Can you explain why not?

When two forces act at a point which does not move, the two forces must be equal and opposite. For example, think of the forces acting on a book lying on the table. Activity 2 shows that when three forces act at a point which does not move, the resultant of two of them formed by the parallelogram law is equal and opposite to the third, indicating that forces must add as vectors. If on your scale drawing of Activity 2 you replace the resultant of \mathbf{W}_1 and \mathbf{W}_2 by the equal and opposite force \mathbf{W}_3 , then \mathbf{W}_1 , \mathbf{W}_2 and \mathbf{W}_3 are the sides of a triangle of forces.

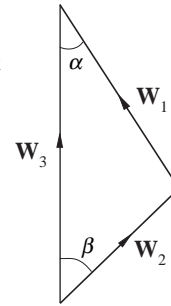

4.3 Resolving forces

Any vector quantity, such as force, can be written in terms of its perpendicular components. This process of writing a force as the sum of its components is called **resolving**, or resolution. Breaking a force down into its resolved parts is important in simplifying two-or three-dimensional situations.

Example

Two forces acting at 54° to each other have magnitudes 6 N and 8 N. Find the components of the smaller force parallel and perpendicular to the larger one.

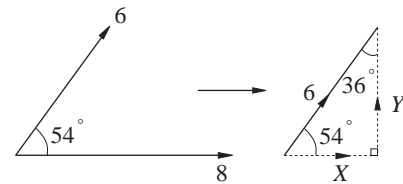

Solution

The component of the 6 N force parallel to the 8 N force, X , is $6 \cos 54^\circ$; while the component of the 6 N force perpendicular to the 8 N force, Y , is $6 \cos 36^\circ$.

In general the component of a force \mathbf{F} in a given direction is

(the magnitude of \mathbf{F}) \times (the cosine of the angle turned through)

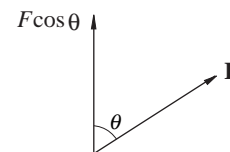

In terms of vectors, it is easier to specify unit vectors \mathbf{i} and \mathbf{j} (the reference system) in the chosen directions and then write each force in \mathbf{i}, \mathbf{j} form. In this example, calling the 8 N force \mathbf{F} and the 6N force \mathbf{G} and defining \mathbf{i}, \mathbf{j} as shown,

 $\mathbf{F} = 8\mathbf{i}$ and $\mathbf{G} = 6 \cos 54^\circ \mathbf{i} + 6 \cos 36^\circ \mathbf{j}$

Example

Four forces act on a particle P. Write each force in \mathbf{i}, \mathbf{j} form, where \mathbf{i} is in the direction of the largest force, and \mathbf{j} is perpendicular to it in an anti-clockwise sense. (Note that when units are not specified on a force diagram, they are newtons).

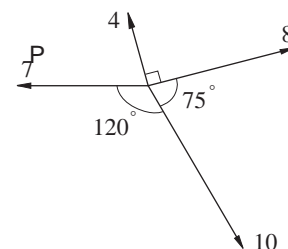

Firstly, it may help to label the forces and re-draw them as shown opposite, marking in suitable angles.

Then $A = 10i$

- (a) $B = 8 \cos 75^\circ i + 8 \sin 15^\circ j$
- (b) $C = -4 \cos 15^\circ i + 4 \sin 75^\circ j$
- (c) $D = -7 \cos 60^\circ i - 7 \sin 30^\circ j$

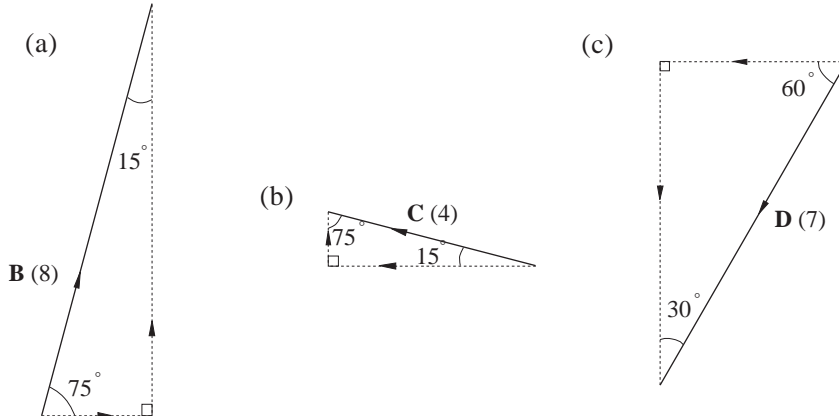
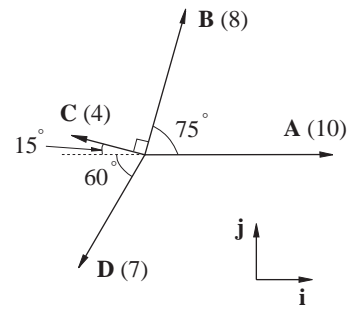

Exercise 4B

1. Write each force in i, j form:

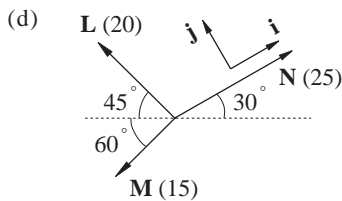
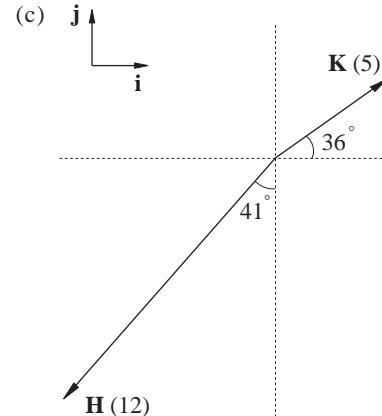
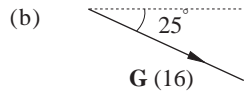
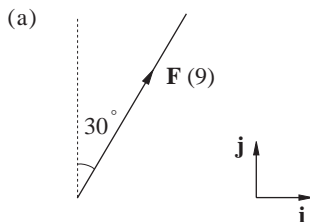

2. A force $F = a i + 12 j$ acts at 20° to i . Find $|F|$ (the magnitude of F) and hence the value of a .

3. For each force F find its magnitude, $|F|$, and the direction it makes with i , taking the anti-clockwise sense as positive. (You may find it helpful to sketch each force).

- (a) $F = 8i + 3j$ (b) $F = -\sqrt{6}i + \sqrt{3}j$
- (c) $F = 20i - 21j$ (d) $F = 7 \sin 27^\circ i + 7 \cos 27^\circ j$
- (e) $F = -4 \sin 31^\circ i + 4 \cos 31^\circ j$

4.4 Friction

In the following activity you will find a mathematical model for the force of friction.

Activity 3 The law of friction

You will need a block to slide on a table, mass holder and masses, small pulley.

Set up the apparatus as shown opposite.

Begin to add 10 g masses to the mass holder, pausing after each mass is added to record the results in a table, as shown below.

total mass of slide	total mass on string	does it slide?
65 g	10 g	No
65 g	20 g	

When the force exerted on the slider by the string attached to the mass holder is **just sufficient** to move the slider, record this point in the table. Under these circumstances the frictional force on the slider, opposing the motion of the slider, is just balanced by the tension in the string. You can assume that the tension in the string is equal to the total weight of the mass holder which is $10 \times \text{mass}$ (ie. you can neglect the frictional resistance of the pulley and the elasticity mass of the string). The plane exerts a normal contact force N on the slider, and since the slider is in equilibrium, N is equal to the weight of the slider ($N = mg$). The frictional force increases as the tension in the string increases until it reaches a maximum value, after which increasing the tension in the string will cause the slider to move. This value of the frictional force is called the **limiting** frictional force.

Now draw a graph showing the frictional force on sliding (which equals the tension in the string) against the normal contact force (which equals the total weight of the slider) as shown.

Now increase the mass of the slider by placing, say, 100 g on it and repeat the above experiment, again noting carefully when limiting friction is reached.

Increase the mass of the slider by adding 200 g and then 300 g repeating the above procedure, and you should obtain a graph similar to the one shown opposite.

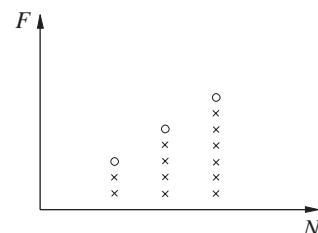
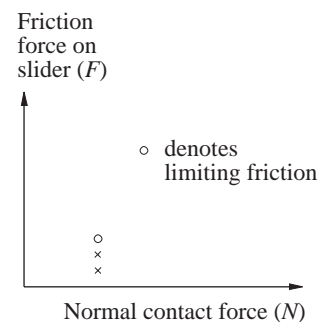
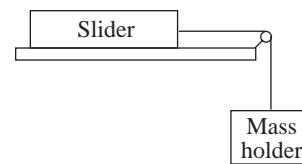

The points representing limiting friction will lie, approximately, on a straight line passing through the origin, the slope of which you denote by μ . Thus

$$F \leq \mu N$$

where F is the frictional force on the slider. The dimensionless number μ is called the **coefficient of friction**.

Is there any reason why the coefficient of friction should be less than 1?

Activity 4

Repeat the experiment in Activity 3 attaching sandpaper to the slider and to the plane.

To summarise the law of friction, consider an object of mass m on a horizontal table and suppose that a horizontal force P is applied as shown opposite.

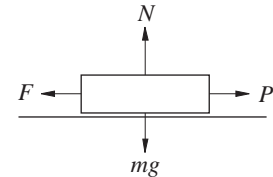

As well as the force P , the other forces acting on the object are the normal contact force, the force of gravity and the force of friction, denoted by N , mg and F respectively. As the force P increases in magnitude the force of friction increases in magnitude until some critical value when the object is on the point of sliding. The law of friction suggests that this critical value is proportional to the magnitude of the normal contact force, so that

$$F = \mu N$$

where μ is a constant called the **coefficient of static friction**. The direction of the force of friction always opposes the direction in which the object is tending to move. Until the critical value is reached

$$F < \mu N.$$

When actually sliding the magnitude of the force of friction is given by

$$F = \mu N.$$

Like the normal contact force, the force of friction is an example of a surface or contact force, applying only when two objects are in contact.

When modelling some physical situations for which the surface of the object and table are sufficiently smooth that the force of friction is negligible, you can make the simplification $F = 0$.

Example

A rope is attached to a crate of mass 70 kg at rest on a flat surface. If the coefficient of friction between the floor and the

crate is 0.6, find the maximum force that the rope can exert on the crate before it begins to move.

Solution

The forces acting on the crate are (i) the force of gravity, (ii) the normal contact force, (iii) the friction force and (iv) the tension in the rope.

Since there is no motion of the crate, the upward force (the normal contact force) must balance the downward force (the force of gravity). Hence

$$N = 70g = 700\text{N (taking } g = 10\text{)} .$$

The law of friction states that:

$$F \leq \mu N ,$$

so in this case

$$F \leq 0.6 \times 70g = 420\text{ N} .$$

As the tension in the rope and the force of friction are the only forces which have horizontal components, the crate will not move unless the tension in the rope is greater than the maximum frictional force. In this case the maximum for the friction is 420 N, and so the maximum force that the rope can exert before the crate begins to move is also 420 N.

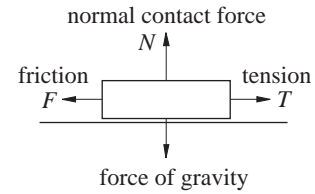

Exercise 4C

- In the following situations the object is about to slide. Find the coefficient of friction in each case. (In this exercise the normal contact force is labelled R).
- A small brick of mass 3 kg is about to slide along a rough horizontal plane being pulled by a stone of mass 2 kg as shown below

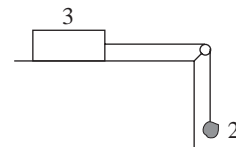
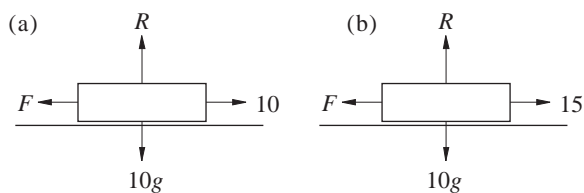

- The coefficient of friction between a sledge and a snowy surface is 0.2. The combined mass of a child and the sledge is 45 kg. What force (acting horizontally) would just move the sledge on a level surface?
 - A small object is being pulled across a horizontal surface at a steady speed by a force of 12 N acting parallel to the surface. If the mass of the object is 5 kg determine the coefficient of friction between the object and the surface.
 - A sledge of mass 12 kg is on level ground.
 - If a horizontal force of 10 N will just move it, find the coefficient of friction μ .
 - If a girl of mass 25 kg sits on the sledge, find the least horizontal force needed to move it.
- The brick and stone are connected by a light inextensible string passing over a pulley.
- Find the coefficient of friction between the brick and the plane.
 - What reaction does the pulley exert?

4.5 Forces in equilibrium

When several forces acting on a body produce a change in its motion, then there must be a resultant non-zero force on the body. When there is no change in motion, then the resultant force must be zero and the body is said to be in **equilibrium**.

When three forces act at a point which is not in equilibrium, the non-zero resultant can be found using the parallelogram law twice.

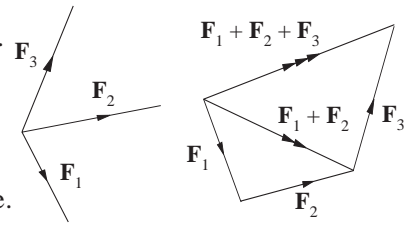

When the forces are in equilibrium, however, the resultant force is zero and the forces form a triangle as Activity 2 shows.

For n forces F_1, F_2, \dots, F_n acting at a point in equilibrium,

$$F_1 + F_2 + \dots + F_n = 0$$

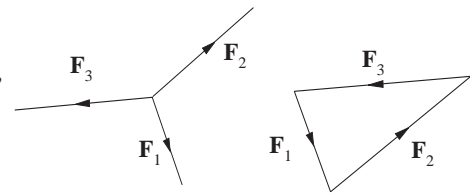

A particle P is at rest on a plane inclined at θ to the horizontal.

The forces acting on P are

- its own weight, of magnitude W , acting vertically downwards;
- a frictional force, of magnitude F , acting up the plane to prevent P from sliding down it;
- a normal contact force, of magnitude N .

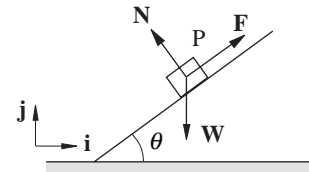

To establish a set of equations between these forces a pair of unit vectors need to be chosen. This can be done in several ways but the two most obvious are a pair horizontally and vertically and a pair along and perpendicular to the plane.

- Taking the unit vectors horizontally and vertically, as shown, the forces can be written

- $W = -W \mathbf{j}$

- $F = F \cos \theta \mathbf{i} + F \cos(90^\circ - \theta) \mathbf{j} = F \cos \theta \mathbf{i} + F \sin \theta \mathbf{j}$

- $N = -N \cos(90^\circ - \theta) \mathbf{i} + N \cos \theta \mathbf{j} = -N \sin \theta \mathbf{i} + N \cos \theta \mathbf{j}$

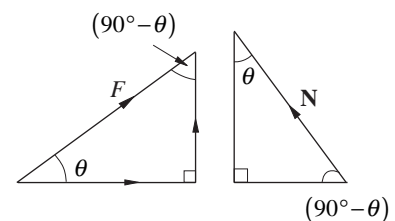

Remember that $\cos(90^\circ - \theta) = \sin \theta$.

Since P is in equilibrium

$$W + F + N = 0,$$

giving

$$-W \mathbf{j} + (F \cos \theta \mathbf{i} + F \sin \theta \mathbf{j}) + (-N \sin \theta \mathbf{i} + N \cos \theta \mathbf{j}) = 0 \mathbf{i} + 0 \mathbf{j}$$

$$(F \cos \theta - N \sin \theta) \mathbf{i} + (-W + F \sin \theta + N \cos \theta) \mathbf{j} = 0 \mathbf{i} + 0 \mathbf{j}.$$

Equating components gives

$$F \cos \theta - N \sin \theta = 0$$

and

$$-W + F \sin \theta + N \cos \theta = 0$$

- (2) Alternatively, taking unit vectors parallel and perpendicular to the plane, the forces can now be written as

(i) $\mathbf{W} = -W \cos(90^\circ - \theta)\mathbf{i} - W \cos \theta \mathbf{j} = -W \sin \theta \mathbf{i} - W \cos \theta \mathbf{j}$

(ii) $\mathbf{F} = F \mathbf{i}$

(iii) $\mathbf{N} = N \mathbf{j}$

Then, since P is in equilibrium,

$$\mathbf{W} + \mathbf{F} + \mathbf{N} = \mathbf{0}$$

that is

$$(-W \sin \theta \mathbf{i} - W \cos \theta \mathbf{j}) + F \mathbf{i} + N \mathbf{j} = 0 \mathbf{i} + 0 \mathbf{j}$$

so

$$(-W \sin \theta + F) \mathbf{i} + (-W \cos \theta + N) \mathbf{j} = 0 \mathbf{i} + 0 \mathbf{j}$$

Equating components gives

$$F = W \sin \theta \quad \text{and} \quad N = W \cos \theta;$$

a much simpler set of equations to work with.

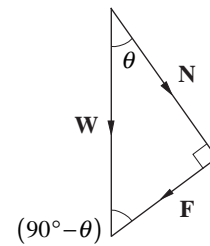
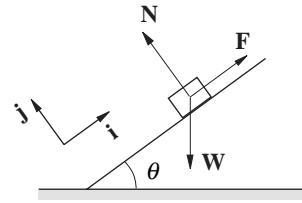

Example

An object, A, lies on a plane inclined at 14.5° . A horizontal force P , applied to A, is on the verge of moving A up the plane. The weight of A is 163.5 N, and the coefficient of friction between A and the plane is 0.6. Unit vectors \mathbf{i} and \mathbf{j} are defined horizontally and vertically. Show that the normal contact force between A and the plane has a magnitude of about 200 N, and find the magnitude of the force P .

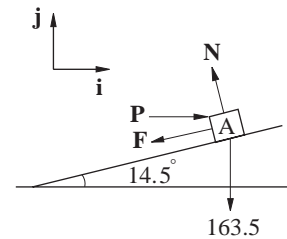

Solution

First of all, write each force in component form:

$$\mathbf{N} = -N \cos 75.5^\circ \mathbf{i} + N \cos 14.5^\circ \mathbf{j}$$

$$\mathbf{P} = P \mathbf{i} \quad \mathbf{W} = -163.5 \mathbf{j}$$

$$\mathbf{F} = -F \cos 14.5^\circ \mathbf{i} - F \cos 75.5^\circ \mathbf{j}$$

Next, since A is stationary, $\mathbf{N} + \mathbf{P} + \mathbf{W} + \mathbf{F} = \mathbf{0} (= 0 \mathbf{i} + 0 \mathbf{j})$.

Equating components gives

$$P - F \cos 14.5^\circ - N \cos 75.5^\circ = 0 \quad \text{for } \mathbf{i},$$

$$N \cos 14.5^\circ - 163.5 - F \cos 75.5^\circ = 0 \quad \text{for } \mathbf{j}.$$

Including the equation arising from the law of friction, you have a set of three equations:-

$$P = F \cos 14.5^\circ + N \cos 75.5^\circ \quad (1)$$

$$N \cos 14.5^\circ - F \cos 75.5^\circ = 163.5 \quad (2)$$

and $F = 0.6N$.

Substituting for F into equation (2) gives

$$N \cos 14.5^\circ - 0.6N \cos 75.5^\circ = 163.5$$

Solving for N ,

$$N(\cos 14.5^\circ - 0.6 \cos 75.5^\circ) = 163.5$$

$$N = \frac{163.5}{0.8179} = 199.897 \text{ N (3 d.p.)}$$

and $N \approx 200 \text{ N}$.

Hence putting $N = 200$ and $F = 0.6N = 120$ into equation (1) gives

$$\begin{aligned} P &= 0.6N \cos 14.5^\circ + N \cos 75.5^\circ \\ &= 166.17 \text{ N.} \end{aligned}$$

Exercise 4D

- A particle A of weight W newtons lies on a plane inclined at 20° to the horizontal. A force of P newtons acting directly up the plane is on the verge of pulling A in that direction. Writing each force in \mathbf{i}, \mathbf{j} form, derive the three equations describing the situation.
- Two particles A and B are attached by a light inextensible string passing over a smooth fixed pulley, as shown, and A has twice the mass of B. Find the smallest value of μ , the coefficient of friction, for equilibrium to be maintained.
- A small ring of weight w is threaded on a curtain rail which is lying horizontally. A light inextensible string is attached to the ring and is on the point of pulling it along the rail when the force exerted is equal to $2w$. Find the coefficient of friction between the ring and the rail.

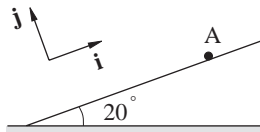

- Two particles A and B are attached by a light inextensible string passing over a smooth fixed pulley, as shown, and A has twice the mass of B. Find the smallest value of μ , the coefficient of friction, for equilibrium to be maintained.

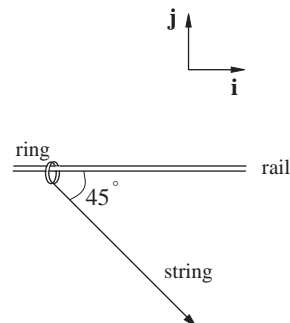
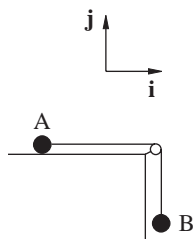

4. A and B are particles connected by a light inextensible string which passes over a smooth fixed pulley attached to a corner of a smooth plane inclined at 37° . Particle B hangs freely. If A has mass 3 kg, find the mass of B given that the system is in equilibrium.

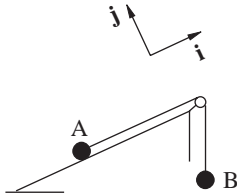

5. A sledge of mass 16 kg is being pulled up the side of a hill of inclination 25° , at a constant velocity. The coefficient of friction between the sledge and the hill is 0.4, and the rope pulling the sledge is at 15° to the hill.

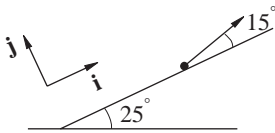

Taking \mathbf{i} and \mathbf{j} parallel and perpendicular to the plane, as shown, and modelling the sledge as a particle, write each force acting on the sledge as a vector and find

- the magnitude of the normal contact force between the hill and the sledge, and
 - the magnitude of the tension in the rope.
6. A ring A is threaded on a rail which is inclined at $22\frac{1}{2}^\circ$ to the horizontal. It is held in equilibrium on the rail by a string attached to a small weight B, the string passing over a smooth fixed pulley in the plane of the wire.

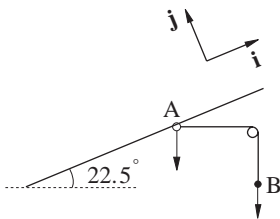

The mass of A is k times the mass of B, and the two portions of string are horizontal and vertical respectively. The ring is on the point of moving up the plane, and the coefficient of friction between A and the rail is 0.1. Find the value of k .

7. A vertical pole has two horizontal wires attached to it at right-angles to each other. The tension in each wire is 70 N in magnitude. In order to maintain the pole in this position a stay is attached to it and to the ground, the stay making an angle of 60° with the ground.

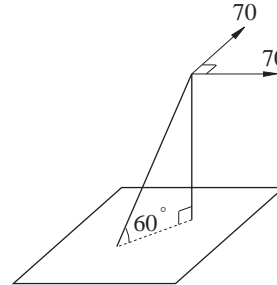

The unit vectors \mathbf{i} and \mathbf{j} are in the directions shown on the plan view, while \mathbf{k} acts vertically upwards.

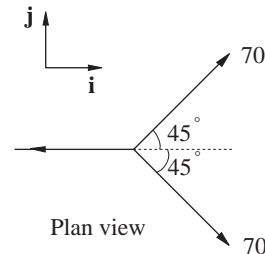

Show that \mathbf{T} , the tension in the stay, is of magnitude 198 N and hence write \mathbf{T} as a vector.

4.6 Non-equilibrium situations

In many cases, an object in motion is constrained so that it does not move in the direction of the force causing it to move. You have come across instances of this already, such as

- (a) a pulling force operating through a rope on a block on a level surface: although the applied force is inclined from the horizontal, the motion is along the surface;
- (b) a block sliding down an inclined plane: the object's weight causes it to move, but clearly not vertically downwards.

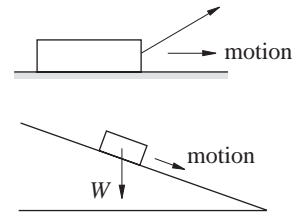

There are, of course, other forces acting on the block in each of these cases. The direction of motion is in the direction of the resultant of **all** relevant forces.

Force and acceleration

Up to this point, you have worked with systems of forces in equilibrium. In these cases the resultant force (that is, the sum of all the forces) is zero. In Question 5 of Exercise 4D the 'particle' (a sledge!) is in motion, and you may have been tempted to think that the forces are not then in equilibrium. Remember, though, that Newton's First Law states that bodies will remain at **constant velocity** (possibly zero) until acted upon by an external force. The implication of this is that, as was shown in Chapter 1, change in motion, that is acceleration, implies force and conversely force implies acceleration. Here force means a non-zero resultant force.

$$\text{force} \Rightarrow \text{acceleration, and acceleration} \Rightarrow \text{force}$$

In Chapter 2 you saw that, for a body of constant mass,

$$\text{resultant force} = \text{mass} \times \text{acceleration}$$

and that a force produces an acceleration in the same direction. Vectorially, then,

$$\mathbf{R} = m\mathbf{a}$$

\mathbf{R} is the resultant force acting on the particle which leads to acceleration \mathbf{a} .

This is Newton's Second Law in vector form.

Example

A block of mass 20 kg is being pulled along level ground by a steady force of 16 N. Friction amounts to 4 N. Calculate the acceleration of the block and the normal contact force between the block and the ground.

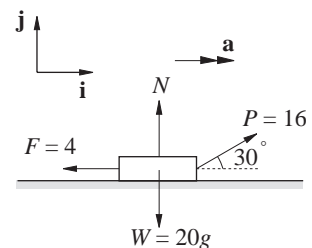

Solution

In vector terms,

$$N + F + W + P = 20a$$

$$\text{or } Nj - 4i - 20gj + (16 \cos 30^\circ i + 16 \cos 60^\circ j) = 20(ai + 0j).$$

Equating components gives

$$\begin{aligned} \text{(i)} \quad 16 \cos 30^\circ - 4 &= 20a \quad \text{so} \quad a = \frac{16 \cos 30^\circ - 4}{20} \\ &= 0.493 \text{ ms}^{-2} \end{aligned}$$

$$\begin{aligned} \text{(j)} \quad N + 16 \cos 60^\circ - 20g &= 0 \quad \text{so} \quad N = 20g - 16 \cos 60^\circ \\ &= 192 \text{ N} \end{aligned}$$

Example

The resultant of five forces acting on a particle is \mathbf{R} . Find the components of each force in the directions indicated and hence \mathbf{R} . If the mass of the particle is 1.5 kg, find the magnitude and direction of its acceleration under the action of these five forces.

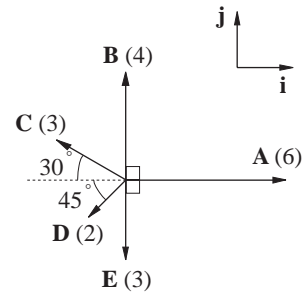
**Solution**

$$A = 6i \quad B = 4j \quad \text{and} \quad E = -3j$$

$$C = -3 \cos 30^\circ i + 3 \cos 60^\circ j$$

$$D = -2 \cos 45^\circ i - 2 \cos 45^\circ j$$

Thus,

$$\begin{aligned} R &= A + B + C + D + E \\ &= (6 - 3 \cos 30^\circ - 2 \cos 45^\circ)i + (4 - 3 + 3 \cos 60^\circ - 2 \cos 45^\circ)j \\ &= 1.99i + 1.09j \end{aligned}$$

Using Newton's Second Law:

$$R = 1.5a, \text{ so } a = \frac{2}{3}R \approx 1.3i + 0.72j$$

and the acceleration has magnitude

$$\sqrt{1.33^2 + 0.72^2} = 1.51 \text{ ms}^{-2}$$

and direction

$$\tan^{-1}\left(\frac{0.72}{1.33}\right) = 28.6^\circ \quad (\text{anticlockwise from } \mathbf{i})$$

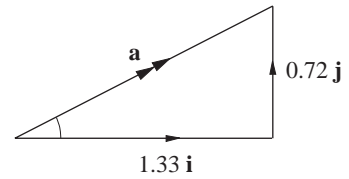

Example

A sledge of mass 12 kg slides 40 m down a slope inclined at 20° . Resistance to motion is 10 N. If the sledge starts from rest, calculate its speed at the bottom of the slope.

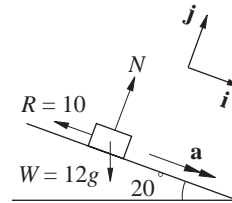

Solution

Notice here that it is important to take one of our directions of reference in the same direction as the acceleration. Also, there is no need to consider the \mathbf{j} components of the forces involved.

Using Newton's Second Law in the \mathbf{i} direction gives

$$12g \cos 70^\circ - 10 = 12a$$

so
$$a = \frac{12g \cos 70^\circ - 10}{12} = 2.59 \text{ ms}^{-2}$$

Since a is constant, it is suitable to use the equation

$$v^2 = u^2 + 2as \text{ with } v \text{ the speed at the bottom, } u = 0 \text{ and } s = 40.$$

Then
$$v^2 = 2 \times 2.59 \times 40 = 207.2$$

and
$$v = 14.4 \text{ ms}^{-1}.$$

Exercise 4E

- In each of these four cases, write each force in terms of its components. Hence find the resultant force, \mathbf{R} , and determine its magnitude and direction.

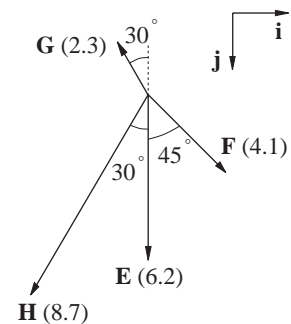
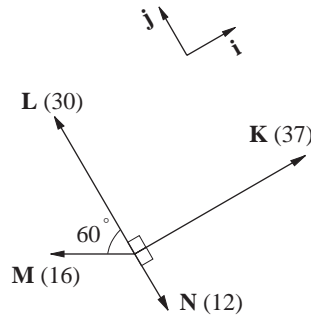
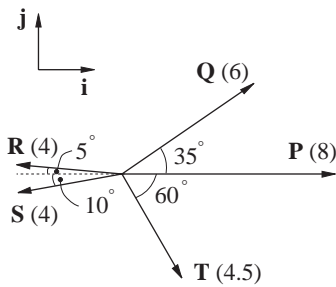
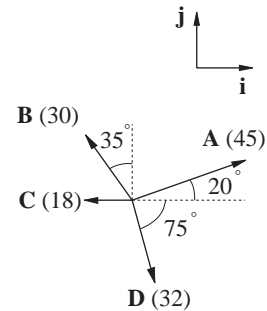

- A brick of mass 4 kg, resting on a horizontal surface, is acted upon by a force of 20 N pulling at 50° to the horizontal. The coefficient of friction between the brick and the surface is $\frac{1}{8}$. Calculate
 - the magnitude of the normal contact force on the brick;
 - the magnitude of the frictional resistance;
 - the speed acquired from rest after 1.5 seconds.
- An archaeologist investigating the mechanics of large catapults used in sieges of castles demonstrates a simplified plan of such a catapult.

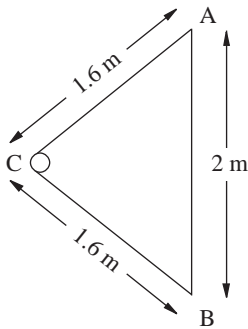

A rock of mass 20 kg is placed at C. The ropes AC and BC are tensioned to provide acceleration.

Measurements suggest an initial acceleration of 30 ms^{-2} upon release. Calculate the tensions in ropes AC and BC

- A body of mass 6 kg is initially at rest on a slope of 24° , in limiting equilibrium. Show that μ , the coefficient of friction between the body and the inclined plane, is $\tan 24^\circ$.

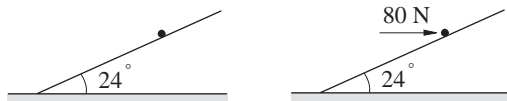

A horizontal force of 80 N is now applied to the body. Calculate the normal contact force acting on the body and the magnitude of its acceleration up the plane.

- Find the magnitude of \mathbf{R} , the resultant of the forces $\mathbf{A} = 3\mathbf{i} - 4\mathbf{j} + \mathbf{k}$, $\mathbf{B} = 3\mathbf{j}$, $\mathbf{C} = -2\sqrt{3}\mathbf{i} + \sqrt{2}\mathbf{k}$ and $\mathbf{D} = -\mathbf{i} + 5\cos 40^\circ \mathbf{j} - 5\sin 40^\circ \mathbf{k}$.

- Five forces act on a particle of mass 2 kg. These are $\mathbf{F}_1 = 0.5\mathbf{i} - 0.2\mathbf{j} + 0.1\mathbf{k}$, $\mathbf{F}_2 = 1.7\mathbf{i} + 0.9\mathbf{j}$, $\mathbf{F}_3 = -\mathbf{i} + 0.25\mathbf{k}$, $\mathbf{F}_4 = -0.62\mathbf{i} - 0.13\mathbf{j} - \sqrt{2}\mathbf{k}$ and $\mathbf{F}_5 = (\sqrt{2} - 1)\mathbf{i}$. Find the acceleration of the particle as a vector, and determine its magnitude.
- A car of mass 800 kg is climbing a hill with an inclination of 8° . The acceleration of the car is 0.5 ms^{-2} , and resistances to motion are a constant 40 N. Calculate the force exerted by the car.

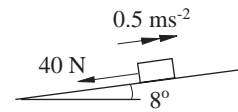

- Three communication leads are attached to the side of a building with tensions $\mathbf{T}_1 = 8\mathbf{i} - \mathbf{j} - \mathbf{k}$, $\mathbf{T}_2 = 2\mathbf{i} + 3\mathbf{j} + \mathbf{k}$ and $\mathbf{T}_3 = 6\mathbf{j} - 5\mathbf{k}$. Find the magnitude of each tension. Find also \mathbf{R} , the resultant force on the attachment, and its magnitude.

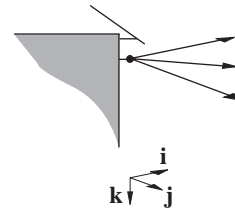

- Two people are pulling a rock of mass 30 kg across level ground. John pulls with a force of 200 N in a direction of 030° , while Sheila pulls with a force of 160 N in a direction of 120° . The coefficient of friction between the rock and ground is 0.6. Assume that the forces exerted on the rock act horizontally.
 - Draw a diagram to show the forces.
 - Find the resultant of the two pulling forces.
 - Find the magnitude of the acceleration of the rock.

4.7 Miscellaneous Exercises

1. (a) Four forces act on the top of a telegraph pole in equilibrium.

$$T_1 = -29i + 12j + k$$

$$T_2 = 8i + 19j - 3k$$

$$T_3 = 22i + 2j - 5k$$

Find T_4 .

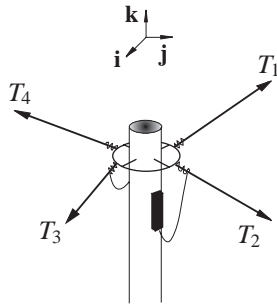

- (b) Three forces, F_1 , F_2 and F_3 act along stays attached to a point part-way up a vertical flag-pole, which is in equilibrium. Given that $F_2 = 3i - 5j - 15k$ and $F_3 = 3i + 2j - 18k$ and the resultant force acts down the pole with magnitude 50 newtons, find F_1 .

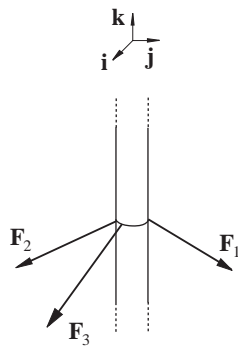

2. A constant force $F = 16i - 21j + 12k$ is applied to a particle, initially at rest at the origin, and of mass 5.8 kg. Find

(a) the magnitude of its acceleration;

(b) the position vector, r , of the particle as a vector function of time.

3. The diagram shows a primitive catapult holding a bolt of mass 600 g. The bolt is attached by strings to points B and C, each string carrying a tension of 100 N. Resistive forces amount to 20 N. Calculate the initial acceleration of the bolt upon release.

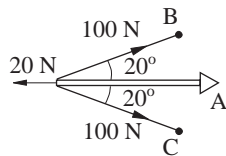

4. A particle of mass 6.5 kg is being pulled up a plane of inclination 36° by a force of 72 N exerted via a piece of string parallel to the plane. The coefficient of friction between the particle and the plane is $\frac{1}{4}$. Find the resultant acceleration of the particle.

5. The diagram shows a simplified model of a swing holding a child with total mass 25 kg. The child is pushed with a force of 30 N in the direction shown. Calculate

(a) the initial acceleration of the child;

(b) the tension in the chain.

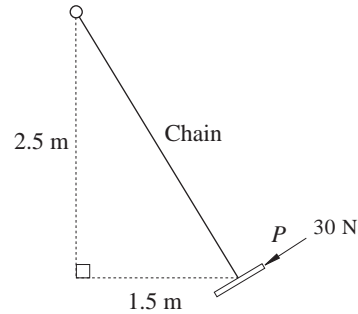

6. Two blocks, A and B, are connected via a light inelastic string which passes over a smooth fixed pulley. A has mass 5 kg and B 3 kg. The coefficient of friction between B and the inclined plane is 0.9. Calculate

(a) the acceleration of the system;

(b) the distance fallen by A in 2 seconds from rest.

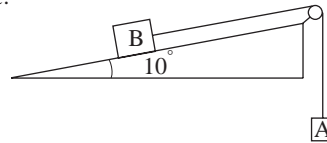

7. A high-wire performer at the circus is riding a uni-cycle across the tightrope. The combined mass of the artiste, the cycle and the balancing pole is 68 kg.

The poles supporting the wire are held by stays attached to the ground at 60° and in the same plane. When the artiste is in the middle of the wire, the wire makes an angle of 10° to the horizontal at either pole.

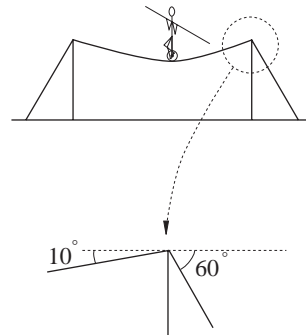

Find the tension in the tightrope and show that the tension in each stay is approximately 3860 N and, if the mass of each pole is 20 kg, find the force exerted by the ground on one pole.

8. Two tugs are towing a large oil tanker into harbour. Tug A's engines can produce a pulling force of 80000 N while Tug B's engines can produce 65000 N of force.

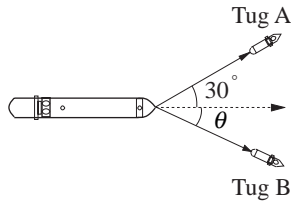

Defining \mathbf{i} and \mathbf{j} suitably, write the forces produced by the tugs in component form, and calculate the angle θ necessary for the tanker to move directly forwards.

Given that there is a resistance to the motion of the tanker of 25 000 N directly opposing motion, find the magnitude of the resultant force on the tanker to the nearest 100 N. Find also the acceleration of the tanker if it has a mass of 20 000 tonnes.

9. Four boys are playing a 'Tug-o-war' game, each pulling horizontally on a rope attached to a light ring. Boy A pulls with a force of $92\mathbf{i} - 33\mathbf{j}$, B with force $66\mathbf{i} + 62\mathbf{j}$ and C with force $-70\mathbf{i} + 99\mathbf{j}$. Given that the ring is in equilibrium, find the force exerted by boy D, and its magnitude.
10. A sledge of mass 30 kg is accelerating down a hill while a boy is trying to prevent it from sliding by pulling on a rope attached to the sledge with a force of 40 N. The hill has inclination 28° and the rope is inclined to the hill at 10° . The coefficient of friction between the sledge and the hill is 0.35.

Taking unit vectors \mathbf{i} down the hill and \mathbf{j} perpendicular to the hill, write each force in component form. Hence find

- the magnitude of the normal contact force on the sledge;
 - the resultant force on the sledge acting down the hill;
 - the magnitude of the sledge's acceleration.
11. Forces act on a telegraph pole along three horizontal wires attached at its top, of magnitudes 80 N, 50 N and 70 N. Taking \mathbf{i} and \mathbf{j} parallel and perpendicular to the 80 N force, write each force as a vector. Given that the pole is in equilibrium, determine the values of α and β , the angles that the 50 N and 70 N forces make with the negative \mathbf{i} direction.

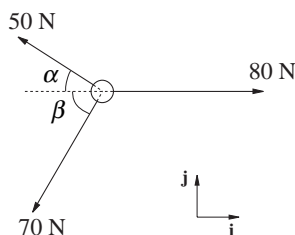

12. A line of (vertical) telephone poles follows the bend of a country road. Each pole has a stay attached to it and to the ground, the stays being symmetrical with respect to the telephone cables connected to the pole, and inclined at θ to the ground. The tension throughout the cables in the system is constant and of magnitude P , and these wires may be assumed to be horizontal.

The tensions in the stays at Pole 1 and Pole 3 are equal and of magnitude T , while the tension in the stay at Pole 2 is of magnitude $\frac{9T}{2}$. The

angles 4α that the cables make with each other at poles 1 and 3 are twice the corresponding angle at pole 2, 2α , as shown.

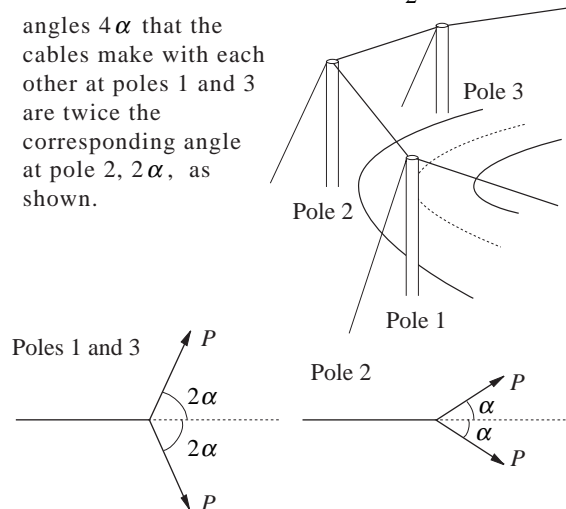

Find the size of the angle α .

13. A particle P of mass 400 g slides down a slope of inclination 32° . Frictional resistance to motion amounts to 1.5 N. Calculate the acceleration of the particle.

After 4 seconds the particle strikes Q, a second particle of mass 500 g initially at rest. The particles coalesce. Given that the initial speed of P was 10 ms^{-1} calculate the speed of P just before impact and the speed of the coalesced particle just after impact.

14. Two particles on an inclined plane are connected by a light string. A has a mass of 4 kg, B 3 kg, and the coefficient of friction between the plane and the particles is 0.3. Determine a , the magnitude of the acceleration of both particles in terms of θ .

When $\theta = 22.3^\circ$ show that $a \approx 1 \text{ ms}^{-2}$ and find the value of θ for which the two particles move at a constant speed.

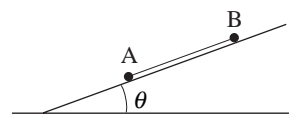

15. A horizontal wire is attached to the top of a pole, and exerts a force of 600 N. In order to maintain equilibrium, two stays are also attached to the top of the pole, and to the ground at 45° . The vertical planes containing the stays make angles of 150° with the wire. Assuming the tensions in the stays to be equal in magnitude T , show that $T \approx 490$ N and find the resultant downward force on the pole produced by the stays to the nearest newton.

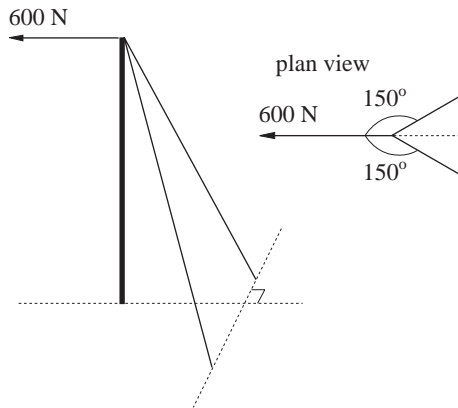

16. At time t seconds a particle P has velocity $[(-4\sin 2t)\mathbf{i} + (4\cos 2t - 4)\mathbf{j}] \text{ ms}^{-1}$ relative to a fixed origin O, where \mathbf{i} and \mathbf{j} are mutually perpendicular unit vectors.
- Find the magnitude of the acceleration of P.
 - When $t = \frac{\pi}{8}$, find the angle that the acceleration makes with the unit vector \mathbf{i} .
 - Given that P passes through O at time $t = 0$, find the position vector of P relative to O at any subsequent time.
- (AEB)

17. At time t seconds the position vectors, relative to a fixed origin O, of two particles P_1 and P_2 are \mathbf{r}_1 and \mathbf{r}_2 metres respectively, where

$$\mathbf{r}_1 = e^{2t}(-3\mathbf{i} + 5\mathbf{j}),$$

$$\mathbf{r}_2 = (2\cos 3t)\mathbf{i} + (5\sin 3t)\mathbf{j}$$

Find the values of $\tan 3t$ such that

- the particles are moving parallel to each other,
- the accelerations of the particles are perpendicular.

(AEB)

18. Three forces $(3\mathbf{i} + 5\mathbf{j})\text{N}$, $(4\mathbf{i} + 11\mathbf{j})\text{N}$, $(2\mathbf{i} + \mathbf{j})\text{N}$ act at a point. Given that \mathbf{i} and \mathbf{j} are perpendicular unit vectors find
- the resultant of the forces in the form $a\mathbf{i} + b\mathbf{j}$,
 - the magnitude of this resultant,
 - the cosine of the angle that the resultant makes with the unit vector \mathbf{i} .
- (AEB)

19. Two forces $(3\mathbf{i} + 2\mathbf{j})\text{N}$ and $(-5\mathbf{i} + \mathbf{j})\text{N}$ act at a point. Find the magnitude of the resultant of these forces and determine the angle which the resultant makes with the unit vector \mathbf{i} .
- (AEB)

20. Three forces $(\mathbf{i} + \mathbf{j})\text{N}$, $(-5\mathbf{i} + 3\mathbf{j})\text{N}$ and $\lambda\mathbf{i}\text{N}$, where \mathbf{i} and \mathbf{j} are perpendicular unit vectors, act at a point. Express the resultant in the form $a\mathbf{i} + b\mathbf{j}$ and find its magnitude in terms of λ . Given that the resultant has magnitude 5 N find the two possible values of λ .

Take the larger value of λ and find the tangent of the angle between the resultant and the unit vector \mathbf{i} .

(AEB)

21. The position vector \mathbf{r} , relative to a fixed origin O, of a particle P is given at time t seconds by

$$\mathbf{r} = e^{-t}(\cos t\mathbf{i} + \sin t\mathbf{j}) \text{ m},$$

where \mathbf{i} and \mathbf{j} are fixed perpendicular unit vectors. Find similar expressions for the velocity and acceleration of P at any time t . Show that the acceleration is always perpendicular to the position vector.

(AEB)

22. The unit vectors \mathbf{i} and \mathbf{j} are horizontal and perpendicular to each other. At 11 a.m. on a particular day, two helicopters P and Q are respectively at points A and B at the same height above the earth. Both helicopters are moving, relative to the air, with the same constant speed $v \text{ kmh}^{-1}$. Also relative to the air P moves

parallel to the unit vector $\frac{3\mathbf{i}}{5} + \frac{4\mathbf{j}}{5}$ and Q moves

parallel to the unit vector $\frac{7\mathbf{i}}{25} - \frac{24\mathbf{j}}{25}$. Determine

in terms of v , \mathbf{i} and \mathbf{j} the velocity of P relative to Q.

Given that the position vector of A relative to B is $(4\mathbf{i} + 5\mathbf{j}) \text{ km}$ and that at noon, the position vector of P relative to Q is $(44\mathbf{i} + 225\mathbf{j}) \text{ km}$, deduce that $v = 125$.

Given also that, at noon, the position vector of P relative to A is $(80\mathbf{i} + 108\mathbf{j}) \text{ km}$, find, in the form $a\mathbf{i} + b\mathbf{j}$, the constant wind velocity.

Find, to the nearest degree, the angle between the velocities of P and Q relative to the ground.

(AEB)